

**PREVIOUS YEARS SOLVED PAPER**

**GATE**

**ELECTRICAL ENGINEERING**

**Ashish Murolia**

**R. K. Kanodia**

**2001 - 2010**

**NODIA & COMAPNY**

**JAIPUR**

**Exclusive Sales Counter & BO:**

**NODIA & COMPANY**

55, Suryalok Complex,

Gunfoundry, Abids, **Hyderabad**

Ph : 040 - 64582577

By Same Author

**GATE Engineering Mathematics**

**MRP 400.00**

For Branch EC, EE, IN, ME, CE and PI

No part of this publication may be reproduced or distributed in any form or any means, electronic, mechanical, photocopying, or otherwise without the prior permission of the author.

**Previous Year Solved Papers**

**GATE**

**Electrical Engineering**

First Edition Nov 2010

Copyright © 2010 by Publisher

Information contained in this book has been obtained by author, from sources believes to be reliable. However, neither Nodia & Company nor its author guarantee the accuracy or completeness of any information herein, and neither Nodia & Company nor its author shall be responsible for any error, omissions, or damages arising out of use of this information. This book is published with the understanding that Nodia & Company and its author are supplying information but are not attempting to render engineering or other professional services.

**MRP 290.00**

**NODIA & COMPANY**

B-8, Dhanshree - Ist, Central Spine, Vidyadhar Nagar, Jaipur - 302023

Ph : +91-141 - 3019130, +91 - 9350292376

**[www.nodia.co.in](http://www.nodia.co.in)**

email : [enquiry@nodia.co.in](mailto:enquiry@nodia.co.in)

---

Printed by Diamond Printing Press, Jaipur

*To Our Parents*





# SYLLABUS

## Engineering Mathematics

### Linear Algebra:

Matrix Algebra, Systems of linear equations, Eigen values and eigen vectors.

### Calculus:

Mean value theorems, Theorems of integral calculus, Evaluation of definite and improper integrals, Partial Derivatives, Maxima and minima, Multiple integrals, Fourier series. Vector identities, Directional derivatives, Line, Surface and Volume integrals, Stokes, Gauss and Green's theorems.

### Differential equations:

First order equation (linear and nonlinear), Higher order linear differential equations with constant coefficients, Method of variation of parameters, Cauchy's and Euler's equations, Initial and boundary value problems, Partial Differential Equations and variable separable method.

### Complex variables:

Analytic functions, Cauchy's integral theorem and integral formula, Taylor's and Laurent' series, Residue theorem, solution integrals.

### Probability and Statistics:

Sampling theorems, Conditional probability, Mean, median, mode and standard deviation, Random variables, Discrete and continuous distributions, Poisson, Normal and Binomial distribution, Correlation and regression analysis.

### Numerical Methods:

Solutions of non linear algebraic equations, single and multi-step methods for differential equations.

### Transform Theory:

Fourier transform, Laplace transform, Z-transform.

## Electrical Engineering

### Electric Circuits and Fields:

Network graph, KCL, KVL, node and mesh analysis, transient response of dc and ac networks; sinusoidal steady-state analysis, resonance, basic filter concepts; ideal current and voltage sources, Thevenin's, Norton's and Superposition and Maximum Power Transfer theorems, two port networks, three phase circuits; Gauss Theorem, electric field and potential due to point, line, plane and spherical charge distributions; Ampere's and Biot-Savart's laws; inductance; dielectrics; capacitance.

## Signals and Systems:

Representation of continuous and discrete-time signals; shifting and scaling operations; linear, time-invariant and causal systems; Fourier series representation of continuous periodic signals; sampling theorem; Fourier, Laplace and Z transforms.

## Electrical Machines:

Single phase transformer - equivalent circuit, phasor diagram, tests, regulation and efficiency; three phase transformers - connections, parallel operation; auto-transformer; energy conversion principles; DC machines - types, windings, generator characteristics, armature reaction and commutation, starting and speed control of motors; three phase induction motors - principles, types, performance characteristics, starting and speed control; single phase induction motors; synchronous machines - performance, regulation and parallel operation of generators, motor starting, characteristics and applications; servo and stepper motors.

## Power Systems:

Basic power generation concepts; transmission line models and performance; cable performance, insulation; corona and radio interference; distribution systems; per-unit quantities; bus impedance and admittance matrices; load flow; voltage control; power factor correction; economic operation; symmetrical components; fault analysis; principles of over-current, differential and distance protection; solid state relays and digital protection; circuit breakers; system stability concepts, swing curves and equal area criterion; HVDC transmission and FACTS concepts.

## Control Systems:

Principles of feedback; transfer function; block diagrams; steady-state errors; Routh and Nyquist techniques; Bode plots; root loci; lag, lead and lead lag compensation; state space model; state transition matrix, controllability and observability.

## Electrical and Electronic Measurements:

Bridges and potentiometers; PMMC, moving iron, dynamometer and induction type instruments; measurement of voltage, current, power, energy and power factor; instrument transformers; digital voltmeters and multimeters; phase, time and frequency measurement; Q-meters; oscilloscopes; potentiometric recorders; error analysis.

## Analog and Digital Electronics:

Characteristics of diodes, BJT, FET; amplifiers - biasing, equivalent circuit and frequency response; oscillators and feedback amplifiers; operational amplifiers - characteristics and applications; simple active filters; VCOs and timers; combinational and sequential logic circuits; multiplexer; Schmitt trigger; multi-vibrators; sample and hold circuits; A/D and D/A converters; 8 bit microprocessor basics, architecture, programming and interfacing.

## Power Electronics and Drives:

Semiconductor power diodes, transistors, thyristors, triacs, GTOs, MOSFETs and IGBTs - static characteristics and principles of operation; triggering circuits; phase control rectifiers; bridge converters - fully controlled and half controlled; principles of choppers and inverters; basic concepts of adjustable speed dc and ac drives.

# **CONTENTS**

<b>UNIT 1</b>	<b>Engineering Mathematics</b>	<b>1</b>
<b>UNIT 2</b>	<b>Electric Circuits &amp; Fields</b>	<b>29</b>
<b>UNIT 3</b>	<b>Signals &amp; Systems</b>	<b>117</b>
<b>UNIT 4</b>	<b>Electric Machines</b>	<b>155</b>
<b>UNIT 5</b>	<b>Power Systems</b>	<b>245</b>
<b>UNIT 6</b>	<b>Control Systems</b>	<b>343</b>
<b>UNIT 7</b>	<b>Electrical &amp; Electronic Measurement</b>	<b>415</b>
<b>UNIT 8</b>	<b>Analog &amp; Digital Electronics</b>	<b>459</b>
<b>UNIT 9</b>	<b>Power Electronics</b>	<b>573</b>





NOTES

**MCQ 1.4**

At  $t = 0$ , the function  $f(t) = \frac{\sin t}{t}$  has

- (A) a minimum (B) a discontinuity  
(C) a point of inflection (D) a maximum

**MCQ 1.5**

An eigenvector of  $P = \begin{pmatrix} 1 & 1 & 0 \\ 0 & 2 & 2 \\ 0 & 0 & 3 \end{pmatrix}$  is

- (A)  $[-1 \ 1 \ 1]^T$  (B)  $[1 \ 2 \ 1]^T$   
(C)  $[1 \ -1 \ 2]^T$  (D)  $[2 \ 1 \ -1]^T$

**MCQ 1.6**

For the differential equation  $\frac{d^2x}{dt^2} + 6\frac{dx}{dt} + 8x = 0$  with initial conditions  $x(0) = 1$  and  $\left. \frac{dx}{dt} \right|_{t=0} = 0$ , the solution is

- (A)  $x(t) = 2e^{-6t} - e^{-2t}$  (B)  $x(t) = 2e^{-2t} - e^{-4t}$   
(C)  $x(t) = -e^{-6t} + 2e^{-4t}$  (D)  $x(t) = e^{-2t} + 2e^{-4t}$

**MCQ 1.7**

For the set of equations,  $x_1 + 2x_2 + x_3 + 4x_4 = 2$  and  $3x_1 + 6x_2 + 3x_3 + 12x_4 = 6$ . The following statement is true.

- (A) Only the trivial solution  $x_1 = x_2 = x_3 = x_4 = 0$  exists  
(B) There are no solutions  
(C) A unique non-trivial solution exists  
(D) Multiple non-trivial solutions exist

**YEAR 2009**

**ONE MARK**

**MCQ 1.8**

The trace and determinant of a  $2 \times 2$  matrix are known to be  $-2$  and  $-35$  respectively. Its eigenvalues are

- (A)  $-30$  and  $-5$  (B)  $-37$  and  $-1$   
(C)  $-7$  and  $5$  (D)  $17.5$  and  $-2$

NOTES

**MCQ 1.13**

$\mathbf{F}(x, y) = (x^2 + xy)\hat{\mathbf{a}}_x + (y^2 + xy)\hat{\mathbf{a}}_y$ . It's line integral over the straight line from  $(x, y) = (0, 2)$  to  $(x, y) = (2, 0)$  evaluates to

- (A)  $-8$  (B)  $4$   
(C)  $8$  (D)  $0$

**YEAR 2008**

**ONE MARKS**

**MCQ 1.14**

$X$  is a uniformly distributed random variable that takes values between 0 and 1. The value of  $E\{X^3\}$  will be

- (A)  $0$  (B)  $1/8$   
(C)  $1/4$  (D)  $1/2$

**MCQ 1.15**

The characteristic equation of a  $(3 \times 3)$  matrix  $P$  is defined as

$$a(\lambda) = |\lambda I - P| = \lambda^3 + \lambda^2 + 2\lambda + 1 = 0$$

If  $I$  denotes identity matrix, then the inverse of matrix  $P$  will be

- (A)  $(P^2 + P + 2I)$  (B)  $(P^2 + P + I)$   
(C)  $-(P^2 + P + I)$  (D)  $-(P^2 + P + 2I)$

**MCQ 1.16**

If the rank of a  $(5 \times 6)$  matrix  $Q$  is 4, then which one of the following statement is correct ?

- (A)  $Q$  will have four linearly independent rows and four linearly independent columns  
(B)  $Q$  will have four linearly independent rows and five linearly independent columns  
(C)  $QQ^T$  will be invertible  
(D)  $Q^T Q$  will be invertible

**NOTES**

- (C)  $\|P\vec{x}\| \geq \|\vec{x}\|$  where at least one vector satisfies  $\|P\vec{x}\| > \|\vec{x}\|$   
 (D) No relationship can be established between  $\|\vec{x}\|$  and  $\|P\vec{x}\|$

**YEAR 2007**

**ONE MARK**

**MCQ 1.22**

$\mathbf{x} = [x_1 \ x_2 \ \dots \ x_n]^T$  is an n-tuple nonzero vector. The  $n \times n$  matrix  $V = \mathbf{x}\mathbf{x}^T$

- (A) has rank zero  
 (B) has rank 1  
 (C) is orthogonal  
 (D) has rank  $n$

**YEAR 2007**

**TWO MARKS**

**MCQ 1.23**

The differential equation  $\frac{dx}{dt} = \frac{1-x}{\tau}$  is discretised using Euler's numerical integration method with a time step  $\Delta T > 0$ . What is the maximum permissible value of  $\Delta T$  to ensure stability of the solution of the corresponding discrete time equation ?

- (A) 1  
 (B)  $\tau/2$   
 (C)  $\tau$   
 (D)  $2\tau$

**MCQ 1.24**

The value of  $\oint_C \frac{dz}{(1+z^2)}$  where  $C$  is the contour  $|z - i/2| = 1$  is

- (A)  $2\pi i$   
 (B)  $\pi$   
 (C)  $\tan^{-1}z$   
 (D)  $\pi i \tan^{-1}z$

**MCQ 1.25**

The integral  $\frac{1}{2\pi} \int_0^{2\pi} \sin(t - \tau) \cos \tau d\tau$  equals

- (A)  $\sin t \cos t$   
 (B) 0  
 (C)  $(1/2) \cos t$   
 (D)  $(1/2) \sin t$



**MCQ 1.26**

A loaded dice has following probability distribution of occurrences

Dice Value	1	2	3	4	5	6
Probability	1/4	1/8	1/8	1/8	1/8	1/4

If three identical dice as the above are thrown, the probability of occurrence of values 1, 5 and 6 on the three dice is

- (A) same as that of occurrence of 3, 4, 5
- (B) same as that of occurrence of 1, 2, 5
- (C) 1/128
- (D) 5/8

**MCQ 1.27**

Let  $\mathbf{x}$  and  $\mathbf{y}$  be two vectors in a 3 dimensional space and  $\langle \mathbf{x}, \mathbf{y} \rangle$  denote their dot product. Then the determinant

$$\det \begin{bmatrix} \langle \mathbf{x}, \mathbf{x} \rangle & \langle \mathbf{x}, \mathbf{y} \rangle \\ \langle \mathbf{y}, \mathbf{x} \rangle & \langle \mathbf{y}, \mathbf{y} \rangle \end{bmatrix}$$

- (A) is zero when  $\mathbf{x}$  and  $\mathbf{y}$  are linearly independent
- (B) is positive when  $\mathbf{x}$  and  $\mathbf{y}$  are linearly independent
- (C) is non-zero for all non-zero  $\mathbf{x}$  and  $\mathbf{y}$
- (D) is zero only when either  $\mathbf{x}$  or  $\mathbf{y}$  is zero

**MCQ 1.28**

The linear operation  $\mathbf{L}(\mathbf{x})$  is defined by the cross product  $\mathbf{L}(\mathbf{x}) = \mathbf{b} \times \mathbf{x}$ , where  $\mathbf{b} = [0 \ 1 \ 0]^T$  and  $\mathbf{x} = [x_1 \ x_2 \ x_3]^T$  are three dimensional vectors. The  $3 \times 3$  matrix  $M$  of this operations satisfies

$$\mathbf{L}(\mathbf{x}) = M \begin{bmatrix} x_1 \\ x_2 \\ x_3 \end{bmatrix}$$

Then the eigenvalues of  $M$  are

- (A) 0, +1, -1
- (B) 1, -1, 1
- (C)  $i, -i, 1$
- (D)  $i, -i, 0$

NOTES

Statement for Linked Answer Question 29 and 30.

Cayley-Hamilton Theorem states that a square matrix satisfies its own characteristic equation. Consider a matrix

$$A = \begin{bmatrix} -3 & 2 \\ -2 & 0 \end{bmatrix}$$

**MCQ 1.29**

$A$  satisfies the relation

- (A)  $A + 3I + 2A^{-1} = 0$  (B)  $A^2 + 2A + 2I = 0$   
(C)  $(A + I)(A + 2I)$  (D)  $\exp(A) = 0$

**MCQ 1.30**

$A^9$  equals

- (A)  $511A + 510I$  (B)  $309A + 104I$   
(C)  $154A + 155I$  (D)  $\exp(9A)$

**YEAR 2006**

**TWO MARKS**

**MCQ 1.31**

The expression  $V = \int_0^H \pi R^2 (1 - h/H)^2 dh$  for the volume of a cone is equal to

- (A)  $\int_0^R \pi R^2 (1 - h/H)^2 dr$  (B)  $\int_0^R \pi R^2 (1 - h/H)^2 dh$   
(C)  $\int_0^H 2\pi r H (1 - r/R) dh$  (D)  $\int_0^R 2\pi r H (1 - \frac{r}{R})^2 dr$

**MCQ 1.32**

A surface  $S(x, y) = 2x + 5y - 3$  is integrated once over a path consisting of the points that satisfy  $(x + 1)^2 + (y - 1)^2 = \sqrt{2}$ . The integral evaluates to

- (A)  $17\sqrt{2}$  (B)  $17\sqrt{2}$   
(C)  $\sqrt{2}/17$  (D) 0

YEAR 2005

TWO MARKS

NOTES

**MCQ 1.40**

For the matrix  $p = \begin{bmatrix} 3 & -2 & 2 \\ 0 & -2 & 1 \\ 0 & 0 & 1 \end{bmatrix}$ , one of the eigen values is equal to  $-2$

Which of the following is an eigen vector ?

(A)  $\begin{bmatrix} 3 \\ -2 \\ 1 \end{bmatrix}$

(B)  $\begin{bmatrix} -3 \\ 2 \\ -1 \end{bmatrix}$

(C)  $\begin{bmatrix} 1 \\ -2 \\ 3 \end{bmatrix}$

(D)  $\begin{bmatrix} 2 \\ 5 \\ 0 \end{bmatrix}$

**MCQ 1.41**

If  $R = \begin{bmatrix} 1 & 0 & -1 \\ 2 & 1 & -1 \\ 2 & 3 & 2 \end{bmatrix}$ , then top row of  $R^{-1}$  is

(A)  $[5 \ 6 \ 4]$

(B)  $[5 \ -3 \ 1]$

(C)  $[2 \ 0 \ -1]$

(D)  $[2 \ -1 \ 1/2]$

**MCQ 1.42**

A fair coin is tossed three times in succession. If the first toss produces a head, then the probability of getting exactly two heads in three tosses is

(A)  $\frac{1}{8}$

(B)  $\frac{1}{2}$

(C)  $\frac{3}{8}$

(D)  $\frac{3}{4}$

**MCQ 1.43**

For the function  $f(x) = x^2 e^{-x}$ , the maximum occurs when  $x$  is equal to

(A) 2

(B) 1

(C) 0

(D)  $-1$

**NOTES**

**MCQ 1.44**

For the scalar field  $u = \frac{x^2}{2} + \frac{y^2}{3}$ , magnitude of the gradient at the point (1, 3) is

- (A)  $\sqrt{\frac{13}{9}}$  (B)  $\sqrt{\frac{9}{2}}$   
(C)  $\sqrt{5}$  (D)  $\frac{9}{2}$

**MCQ 1.45**

For the equation  $x''(t) + 3x'(t) + 2x(t) = 5$ , the solution  $x(t)$  approaches which of the following values as  $t \rightarrow \infty$  ?

- (A) 0 (B)  $\frac{5}{2}$   
(C) 5 (D) 10

\*\*\*\*\*

## SOLUTION

### SOL 1.1

$$\begin{aligned}
 P &= \int_0^1 x e^x dx \\
 &= \left[ x \int e^x dx \right]_0^1 - \int_0^1 \left[ \frac{d}{dx}(x) \int e^x dx \right] dx \\
 &= \left[ x e^x \right]_0^1 - \int_0^1 (1) e^x dx \\
 &= (e^1 - 0) - \left[ e^x \right]_0^1 \\
 &= e^1 - [e^1 - e^0] \\
 &= 1
 \end{aligned}$$

Hence (B) is correct option.

### SOL 1.2

$$\text{Radial vector } \vec{r} = x\hat{i} + y\hat{j} + z\hat{k}$$

$$\text{Divergence} = \nabla \cdot \vec{r}$$

$$\begin{aligned}
 &= \left( \frac{\partial}{\partial x} \hat{i} + \frac{\partial}{\partial y} \hat{j} + \frac{\partial}{\partial z} \hat{k} \right) \cdot (x\hat{i} + y\hat{j} + z\hat{k}) \\
 &= \frac{\partial x}{\partial x} + \frac{\partial y}{\partial y} + \frac{\partial z}{\partial z} \\
 &= 1 + 1 + 1 = 3
 \end{aligned}$$

Hence (A) is correct option.

### SOL 1.3

No of white balls= 4, no of red balls= 3

If first removed ball is white then remaining no of balls= 6 (3 white, 3 red)  
we have 6 balls, one ball can be choose in  ${}^6C_1$  ways, since there are three red balls so probability that the second ball is red is

$$\begin{aligned}
 P &= \frac{{}^6C_1}{{}^3C_1} \\
 &= \frac{3}{6} = \frac{1}{2}
 \end{aligned}$$

Hence (C) is correct option.

**NOTES**

**SOL 1.4**

Function  $f(t) = \frac{\sin t}{t} = \text{sinc } t$  has a maxima at  $t = 0$  as shown below

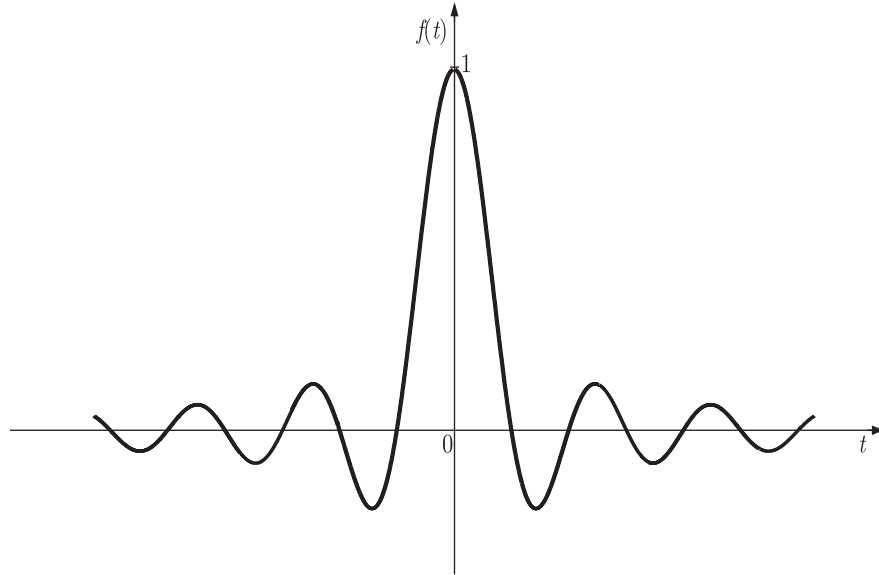

Hence (D) is correct option.

**SOL 1.5**

Let eigen vector

$$\mathbf{X} = [x_1 \ x_2 \ x_3]^T$$

Eigen vector corresponding to  $\lambda_1 = 1$

$$[A - \lambda_1 I] \mathbf{X} = 0$$

$$\begin{bmatrix} 0 & 1 & 0 \\ 0 & 1 & 2 \\ 0 & 0 & 2 \end{bmatrix} \begin{bmatrix} x_1 \\ x_2 \\ x_3 \end{bmatrix} = \begin{bmatrix} 0 \\ 0 \\ 0 \end{bmatrix}$$

$$x_2 = 0$$

$$x_2 + 2x_3 = 0 \Rightarrow x_3 = 0 \text{ (not given in the option)}$$

Eigen vector corresponding to  $\lambda_2 = 2$

$$[A - \lambda_2 I] \mathbf{X} = 0$$

$$\begin{bmatrix} -1 & 1 & 0 \\ 0 & 0 & 2 \\ 0 & 0 & 1 \end{bmatrix} \begin{bmatrix} x_1 \\ x_2 \\ x_3 \end{bmatrix} = \begin{bmatrix} 0 \\ 0 \\ 0 \end{bmatrix}$$

**NOTES**

**SOL 1.7**

Set of equations

$$x_1 + 2x_2 + x_3 + 4x_4 = 2 \quad \dots(1)$$

$$3x_1 + 6x_2 + 3x_3 + 12x_4 = 6 \quad \dots(2)$$

or  $3(x_1 + 2x_2 + x_3 + 4x_4) = 3 \times 2$  Equation (2) is same as equation(1) except a constant multiplying factor of 3.

So infinite (multiple) no. of non-trivial solution exists.

Hence (C) is correct option.

**SOL 1.8**

Let the matrix is  $A = \begin{bmatrix} a & b \\ c & d \end{bmatrix}$

Trace of a square matrix is sum of its diagonal entries

$$\text{Trace } A = a + d = -2$$

Determinant  $ad - bc = -35$

Eigenvalue  $|A - \lambda I| = 0$

$$\begin{vmatrix} a - \lambda & b \\ c & d - \lambda \end{vmatrix} = 0$$

$$(a - \lambda)(d - \lambda) - bc = 0$$

$$\lambda^2 - (a + d)\lambda + (ad - bc) = 0$$

$$\lambda^2 - (-2)\lambda + (-35) = 0$$

$$\lambda^2 + 2\lambda - 35 = 0$$

$$(\lambda - 5)(\lambda + 7) = 0$$

$$\lambda_1, \lambda_2 = 5, -7$$

Hence (C) is correct option.

**NOTES**

**SOL 1.12**

An iterative sequence in Newton-Raphson's method is obtained by following expression

$$x_{k+1} = x_k - \frac{f(x_k)}{f'(x_k)}$$

$$f(x) = x^2 - 117$$

$$f'(x) = 2x$$

So  $f(x_k) = x_k^2 - 117$

$$f'(x_k) = 2x_k = 2 \times 117$$

So 
$$x_{k+1} = x_k - \frac{x_k^2 - 117}{2x_k}$$

$$= x_k - \frac{1}{2} \left[ x_k + \frac{117}{x_k} \right]$$

Hence (D) is correct option.

Equation of straight line

$$y - 2 = \frac{0 - 2}{2 - 0}(x - 0)$$

$$y - 2 = -x$$

$$\begin{aligned} \vec{F} \cdot d\vec{l} &= [(x^2 + xy)\hat{a}_x + (y^2 + xy)\hat{a}_y] [dx\hat{a}_x + dy\hat{a}_y + dz\hat{a}_z] \\ &= (x^2 + xy) dx + (y^2 + xy) dy \end{aligned}$$

Limit of  $x$  : 0 to 2

Limit of  $y$  : 2 to 0

$$\int \vec{F} \cdot d\vec{l} = \int_0^2 (x^2 + xy) dx + \int_2^0 (y^2 + xy) dy$$

Line 
$$y - 2 = -x$$

$$dy = -dx$$

So 
$$\begin{aligned} \int \vec{F} \cdot d\vec{l} &= \int_0^2 [x^2 + x(2 - x)] dx + \int_2^0 y^2 + (2 - y) y dy \\ &= \int_0^2 2x dx + \int_2^0 2y dy \\ &= 2 \left[ \frac{x^2}{2} \right]_0^2 + 2 \left[ \frac{y^2}{2} \right]_2^0 \\ &= 4 - 4 \\ &= 0 \end{aligned}$$

Hence (D) is correct option.



**SOL 1.13**

$X$  is uniformly distributed between 0 and 1

So probability density function

$$f_X(X) = \begin{cases} 1, & 0 < x < 1 \\ 0, & \text{otherwise} \end{cases}$$

So,

$$\begin{aligned} E\{X^3\} &= \int_0^1 X^3 f_X(X) dx \\ &= \int_0^1 X^3 (1) dx \\ &= \left[ \frac{X^4}{4} \right]_0^1 \\ &= \frac{1}{4} \end{aligned}$$

Hence (C) is correct option

**SOL 1.14**

According to CAYLEY-HAMILTON Theorem every non-singular square matrix satisfies its own characteristic equation.

Characteristic equation

$$a(\lambda) = |\lambda I - P| = \lambda^3 + \lambda^2 + 2\lambda + 1 = 0$$

Matrix  $P$  satisfies above equation

$$\begin{aligned} P^3 + P^2 + 2P + I &= 0 \\ I &= -(P^3 + P^2 + 2P) \end{aligned}$$

Multiply both sides by  $P^{-1}$

$$P^{-1} = -(P^2 + P + 2I)$$

Hence (D) is correct option.

**SOL 1.15**

Rank of a matrix is no. of linearly independent rows and columns of the matrix.

Here Rank  $\rho(Q) = 4$

So  $Q$  will have 4 linearly independent rows and four independent columns.

Hence (A) is correct option.

**SOL 1.18**

$$\begin{aligned} A' &= (A^T A)^{-1} A^T \\ &= A^{-1} (A^T)^{-1} A^T \\ &= A^{-1} I \end{aligned}$$

Put  $A' = A^{-1}I$  in all option.

option (A)  $AA'A = A$   
 $AA^{-1}A = A$   
 $A = A$  (true)

option (B)  $(AA')^2 = I$   
 $(AA^{-1}I)^2 = I$   
 $(I)^2 = I$  (true)

option (C)  $A'A = I$   
 $A^{-1}IA = I$   
 $I = I$  (true)

option (D)  $AA'A = A'$   
 $AA^{-1}IA = A \neq A'$  (false)

Hence (D) is correct option

**SOL 1.19**

$$\begin{aligned} \frac{dx}{dt} &= e^{-2t} u(t) \\ x &= \int e^{-2t} u(t) dt \\ x &= \int_0^1 e^{-2t} dt \\ x &= \int_0^1 f(t) dt, \\ t &= .01 \text{ s} \end{aligned}$$

From trapezoid rule

$$\begin{aligned} \int_{t_0}^{t_0+nh} f(t) dt &= \frac{h}{2}[f(0) + f(.01)] \\ \int_0^1 f(t) dt &= \frac{.01}{2}[e^0 + e^{-.02}], h = .01 \\ &= .0099 \end{aligned}$$

Hence (C) is correct option.

So by Cauchy's integral formula

$$\begin{aligned} \oint_C \frac{dz}{1+z^2} &= 2\pi i \lim_{z \rightarrow i} (z-i) \frac{1}{(z+i)(z-i)} \\ &= 2\pi i \lim_{z \rightarrow i} \frac{1}{z+i} \\ &= 2\pi i \times \frac{1}{2i} \\ &= \pi \end{aligned}$$

Hence (A) is correct option.

**SOL 1.24**

**SOL 1.25**

Probability of occurrence of values 1,5 and 6 on the three dice is

$$\begin{aligned} P(1,5,6) &= P(1)P(5)P(6) \\ &= \frac{1}{4} \times \frac{1}{8} \times \frac{1}{4} \\ &= \frac{1}{128} \end{aligned}$$

In option (A)

$$\begin{aligned} P(3,4,5) &= P(3)P(4)P(5) \\ &= \frac{1}{8} \times \frac{1}{8} \times \frac{1}{8} \\ &= \frac{1}{512} \end{aligned}$$

In option (B)

$$\begin{aligned} P(1,2,5) &= P(1)P(2)P(5) \\ &= \frac{1}{4} \times \frac{1}{8} \times \frac{1}{8} \\ &= \frac{1}{256} \end{aligned}$$

Hence (C) is correct option.

**SOL 1.26**

$$\begin{aligned} \det \begin{bmatrix} \mathbf{x} \cdot \mathbf{x} & \mathbf{x} \cdot \mathbf{y} \\ \mathbf{y} \cdot \mathbf{x} & \mathbf{y} \cdot \mathbf{y} \end{bmatrix} &= (\mathbf{x} \cdot \mathbf{x})(\mathbf{y} \cdot \mathbf{y}) - (\mathbf{x} \cdot \mathbf{y})(\mathbf{y} \cdot \mathbf{x}) \\ &= 0 \text{ only when } \mathbf{x} \text{ or } \mathbf{y} \text{ is zero} \end{aligned}$$

Hence (D) is correct option.

**NOTES**

**SOL 1.27**

**SOL 1.28**

For characteristic equation

$$\begin{bmatrix} -3 - \lambda & 2 \\ -1 & 0 - \lambda \end{bmatrix} = 0$$

or  $(-3 - \lambda)(-\lambda) + 2 = 0$   
 $(\lambda + 1)(\lambda + 2) = 0$

According to Cayley-Hamilton theorem

$$(A + I)(A + 2I) = 0$$

Hence (C) is correct option.

**SOL 1.29**

According to Cayley-Hamilton theorem

$$(A + I)(A + 2I) = 0$$

or  $A^2 + 3A + 2I = 0$

or  $A^2 = -(3A + 2I)$

or  $A^4 = (3A + 2I)^2 = (9A^2 + 12A + 4I)$   
 $= 9(-3A - 2I) + 12A + 4I$   
 $= -15A - 14I$

$$A^8 = (-15A - 14I)^2 = 225A^2 + 420A + 196I$$

$$= 225(-3A - 2I) + 420A + 196I$$

$$= -255A - 254I$$

$$A^9 = -255A^2 - 254A$$

$$= -255(-3A - 2I) - 254A = 511A + 510I$$

Hence (A) is correct option.

**SOL 1.30**

Volume of the cone

$$V = \int_0^H \pi R^2 \left(1 - \frac{h}{H}\right)^2 dh$$

By solving the above integral

$$V = \frac{1}{3} \pi R^2 H$$

Solve all integrals given in options only for option (D)

$$\int_0^R 2\pi r H \left(1 - \frac{r}{R}\right)^2 dr = \frac{1}{3} \pi R^2 H$$

Hence (D) is correct option.

**SOL 1.40**

If the toss produces head, then for exactly two head in three tosses three tosses there must produce one head in next two tosses. The probability of one head in two tosses will be  $1/2$ .

Hence (B) is correct option.

**SOL 1.41**

We have

$$f(x) = x^2 e^{-x}$$

or

$$f'(x) = 2xe^{-x} - x^2 e^{-x} \\ = xe^{-x}(2 - x)$$

$$f''(x) = (x^2 - 4x + 2) e^{-x}$$

Now for maxima and minima,  $f'(x) = 0$

$$xe^{-x}(2 - x) = 0$$

or

$$x = 0, 2$$

at  $x = 0$

$$f''(0) = 1 (+ve)$$

at  $x = 2$

$$f''(2) = -2e^{-2} (-ve)$$

Now  $f''(0) = 1$  and  $f''(2) = -2e^{-2} < 0$ . Thus  $x = 2$  is point of maxima

Hence (A) is correct option.

**SOL 1.42**

$$\nabla u = \left( \hat{i} \frac{\partial}{\partial x} + \hat{j} \frac{\partial}{\partial y} \right) u$$

$$= \hat{i} \frac{\partial u}{\partial x} + \hat{j} \frac{\partial u}{\partial y}$$

$$= x\hat{i} + \frac{2}{3}y\hat{j}$$

At (1, 3) magnitude is  $|\nabla u| = \sqrt{x^2 + \left(\frac{2}{3}y\right)^2}$

$$= \sqrt{1 + 4}$$

$$= \sqrt{5}$$

Hence (C) is correct option.

**SOL 1.43**

$$\frac{d^2 x}{dt^2} + \frac{3dx}{dt} + 2x(t) = 5$$

Taking laplace transform on both sides of above equation.

$$s^2 X(s) + 3sX(s) + 2X(s) = \frac{5}{s}$$

**NOTES**

$$X(s) = \frac{5}{s(s^2 + 3s + 2)}$$

From final value theorem

$$\begin{aligned}\lim_{t \rightarrow \infty} x(t) &= \lim_{s \rightarrow 0} X(s) \\ &= \lim_{s \rightarrow 0} s \frac{5}{s(s^2 + 3s + 2)} \\ &= \frac{5}{2}\end{aligned}$$

Hence (B) is correct option.

\*\*\*\*\*

## 2 CHAPTER

# Electrical Circuits & Fields

YEAR 2010

ONE MARK

### MCQ 2.1

The switch in the circuit has been closed for a long time. It is opened at  $t = 0$ . At  $t = 0^+$ , the current through the  $1 \mu\text{F}$  capacitor is

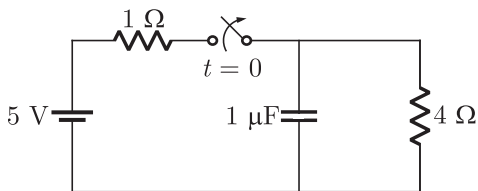

- (A) 0 A                                      (B) 1 A  
(C) 1.25 A                                    (D) 5 A

### MCQ 2.2

As shown in the figure, a  $1 \Omega$  resistance is connected across a source that has a load line  $v + i = 100$ . The current through the resistance is

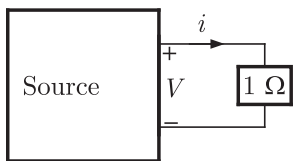

- (A) 25 A                                      (B) 50 A  
(C) 100 A                                    (C) 200 A

**MCQ 2.3**

If the  $12\ \Omega$  resistor draws a current of  $1\ \text{A}$  as shown in the figure, the value of resistance  $R$  is

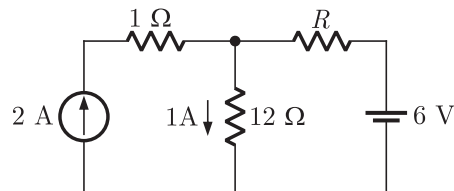

- (A)  $4\ \Omega$  (B)  $6\ \Omega$   
(C)  $8\ \Omega$  (D)  $18\ \Omega$

**MCQ 2.4**

The two-port network P shown in the figure has ports 1 and 2, denoted by terminals (a,b) and (c,d) respectively. It has an impedance matrix  $Z$  with parameters denoted by  $Z_{ij}$ . A  $1\ \Omega$  resistor is connected in series with the network at port 1 as shown in the figure. The impedance matrix of the modified two-port network (shown as a dashed box ) is

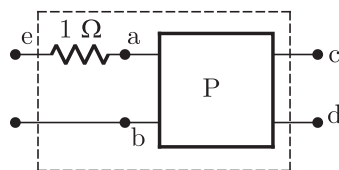

- (A)  $\begin{pmatrix} Z_{11} + 1 & Z_{12} + 1 \\ Z_{21} & Z_{22} + 1 \end{pmatrix}$  (B)  $\begin{pmatrix} Z_{11} + 1 & Z_{12} \\ Z_{21} & Z_{22} + 1 \end{pmatrix}$   
(C)  $\begin{pmatrix} Z_{11} + 1 & Z_{12} \\ Z_{21} & Z_{22} \end{pmatrix}$  (D)  $\begin{pmatrix} Z_{11} + 1 & Z_{12} \\ Z_{21} + 1 & Z_{22} \end{pmatrix}$

**MCQ 2.5**

The current through the  $2\ \text{k}\Omega$  resistance in the circuit shown is



**NOTES**

**MCQ 2.8**

The equivalent capacitance of the input loop of the circuit shown is

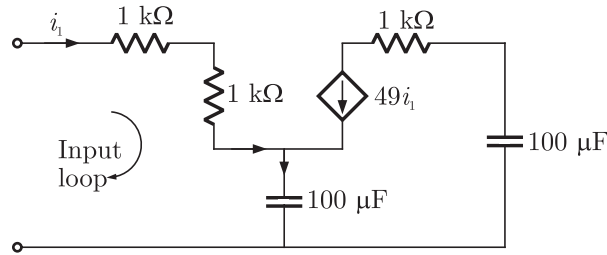

- (A)  $2 \mu\text{F}$  (B)  $100 \mu\text{F}$   
(C)  $200 \mu\text{F}$  (D)  $4 \mu\text{F}$

**MCQ 2.9**

For the circuit shown, find out the current flowing through the  $2 \Omega$  resistance. Also identify the changes to be made to double the current through the  $2 \Omega$  resistance.

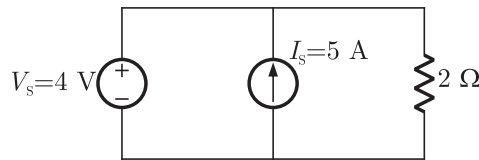

- (A) (5 A; Put  $V_S = 30 \text{ V}$ ) (B) (2 A; Put  $V_S = 8 \text{ V}$ )  
(C) (5 A; Put  $I_S = 10 \text{ A}$ ) (D) (7 A; Put  $I_S = 12 \text{ A}$ )

**Statement for Linked Answer Question 10 and 11 :**

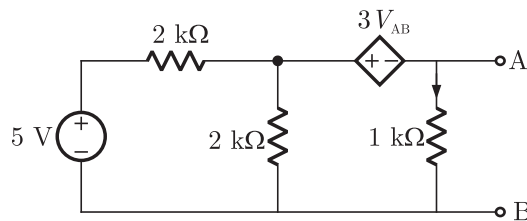

**MCQ 2.10**

For the circuit given above, the Thevenin's resistance across the terminals A and B is

- (A)  $0.5 \text{ k}\Omega$  (B)  $0.2 \text{ k}\Omega$   
(C)  $1 \text{ k}\Omega$  (D)  $0.11 \text{ k}\Omega$

**MCQ 2.11**

For the circuit given above, the Thevenin's voltage across the terminals A and B is

- (A) 1.25 V (B) 0.25 V  
(C) 1 V (D) 0.5 V

**YEAR 2008**

**ONE MARK**

**MCQ 2.12**

The number of chords in the graph of the given circuit will be

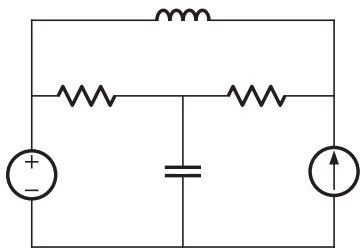

- (A) 3 (B) 4  
(C) 5 (D) 6

**MCQ 2.13**

The Thevenin's equivalent of a circuit operation at  $\omega = 5$  rads/s, has  $V_{oc} = 3.71 \angle -15.9^\circ$  V and  $Z_0 = 2.38 - j0.667 \Omega$ . At this frequency, the minimal realization of the Thevenin's impedance will have a

- (A) resistor and a capacitor and an inductor  
(B) resistor and a capacitor  
(C) resistor and an inductor  
(D) capacitor and an inductor

**YEAR 2008**

**TWO MARKS**

**MCQ 2.14**

The time constant for the given circuit will be



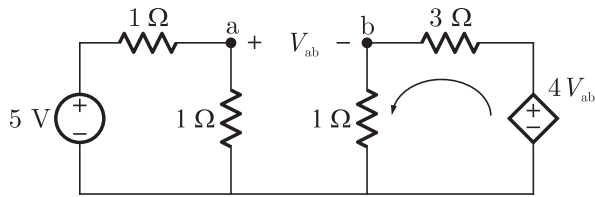

- (A) 0.31 A                                      (B) 1.25 A  
(C) 1.75 A                                      (D) 2.5 A

**Statement for Linked Answer Question 18 and 19.**

The current  $i(t)$  sketched in the figure flows through a initially uncharged 0.3 nF capacitor.

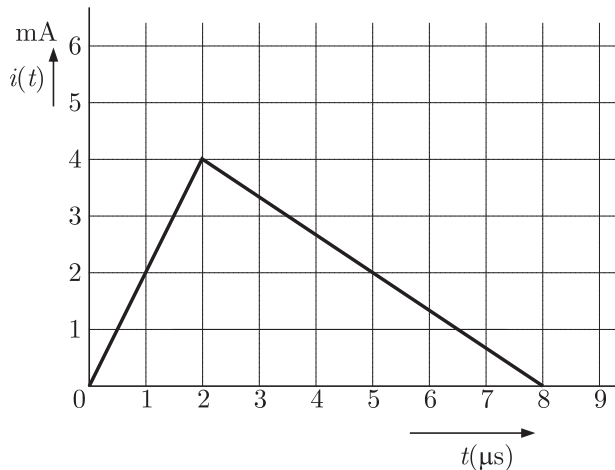

**MCQ 2.18**

The charge stored in the capacitor at  $t = 5 \mu\text{s}$ , will be

- (A) 8 nC    (B) 10 nC  
(C) 13 nC                                      (D) 16 nC

**MCQ 2.19**

The capacitor charged upto 5 ms, as per the current profile given in the figure, is connected across an inductor of 0.6 mH. Then the value of voltage across the capacitor after  $1 \mu\text{s}$  will approximately be

- (A) 18.8 V                                      (B) 23.5 V  
(C) -23.5 V                                      (D) -30.6 V

YEAR 2007

TWO MARKS

NOTES

**MCQ 2.24**

The state equation for the current  $I_1$  in the network shown below in terms of the voltage  $V_X$  and the independent source  $V$ , is given by

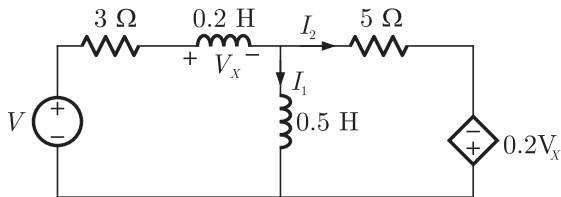

- (A)  $\frac{dI_1}{dt} = -1.4V_X - 3.75I_1 + \frac{5}{4}V$
- (B)  $\frac{dI_1}{dt} = 1.4V_X - 3.75I_1 - \frac{5}{4}V$
- (C)  $\frac{dI_1}{dt} = -1.4V_X + 3.75I_1 + \frac{5}{4}V$
- (D)  $\frac{dI_1}{dt} = -1.4V_X + 3.75I_1 - \frac{5}{4}V$

**MCQ 2.25**

In the circuit shown in figure. Switch  $SW_1$  is initially closed and  $SW_2$  is open. The inductor  $L$  carries a current of 10 A and the capacitor charged to 10 V with polarities as indicated.  $SW_2$  is closed at  $t = 0$  and  $SW_1$  is opened at  $t = 0$ . The current through  $C$  and the voltage across  $L$  at  $(t = 0^+)$  is

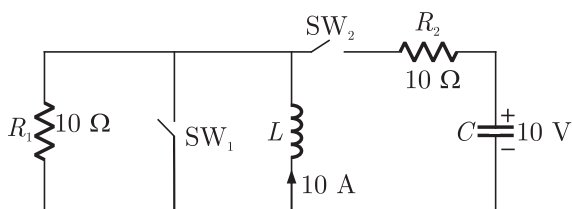

- (A) 55 A, 4.5 V
- (B) 5.5 A, 45 V
- (C) 45 A, 5.5 A
- (D) 4.5 A, 55 V

**NOTES**

**MCQ 2.26**

The R-L-C series circuit shown in figure is supplied from a variable frequency voltage source. The admittance - locus of the R-L-C network at terminals AB for increasing frequency  $\omega$  is

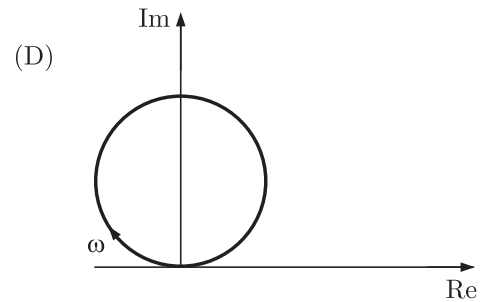
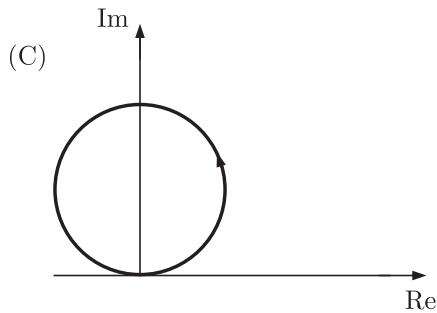
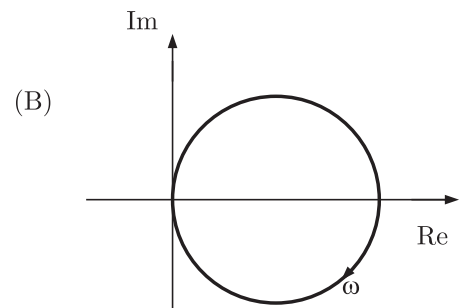
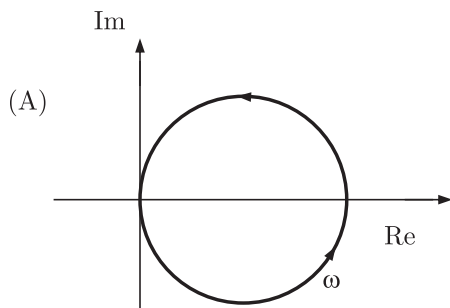
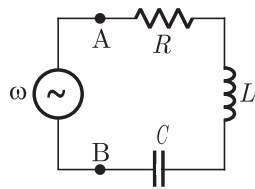

**MCQ 2.27**

In the figure given below all phasors are with reference to the potential at point "O". The locus of voltage phasor  $V_{YX}$  as  $R$  is varied from zero to infinity is shown by

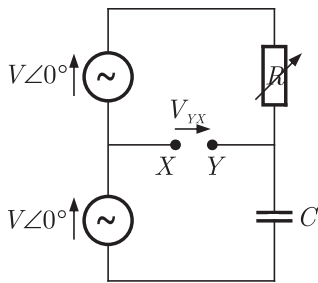

- (A) (B)
- (C) (D)

**MCQ 2.28**

A 3 V DC supply with an internal resistance of  $2\ \Omega$  supplies a passive non-linear resistance characterized by the relation  $V_{NL} = I_{NL}^2$ . The power dissipated in the non linear resistance is

- (A) 1.0 W (B) 1.5 W  
(C) 2.5 W (D) 3.0 W

**MCQ 2.29**

The matrix A given below in the node incidence matrix of a network. The columns correspond to branches of the network while the rows correspond to nodes. Let  $V = [V_1\ V_2\ \dots\ V_6]^T$  denote the vector of branch voltages while  $I = [i_1\ i_2\ \dots\ i_6]^T$  that of branch currents. The vector  $E = [e_1\ e_2\ e_3\ e_4]^T$  denotes the vector of node voltages relative to a common ground.

$$A = \begin{bmatrix} 1 & 1 & 1 & 0 & 0 & 0 \\ 0 & -1 & 0 & -1 & 1 & 0 \\ -1 & 0 & 0 & 0 & -1 & -1 \\ 0 & 0 & -1 & 1 & 0 & 1 \end{bmatrix}$$

NOTES

Which of the following statement is true ?

- (A) The equations  $V_1 - V_2 + V_3 = 0, V_3 + V_4 - V_5 = 0$  are KVL equations for the network for some loops
- (B) The equations  $V_1 - V_3 - V_6 = 0, V_4 + V_5 - V_6 = 0$  are KVL equations for the network for some loops
- (C)  $E = AV$
- (D)  $AV = 0$  are KVI equations for the network

**MCQ 2.30**

A solid sphere made of insulating material has a radius  $R$  and has a total charge  $Q$  distributed uniformly in its volume. What is the magnitude of the electric field intensity,  $E$ , at a distance  $r(0 < r < R)$  inside the sphere ?

- (A)  $\frac{1}{4\pi\epsilon_0} \frac{Qr}{R^3}$
- (B)  $\frac{3}{4\pi\epsilon_0} \frac{Qr}{R^3}$
- (C)  $\frac{1}{4\pi\epsilon_0} \frac{Q}{r^2}$
- (D)  $\frac{1}{4\pi\epsilon_0} \frac{QR}{r^3}$

**Statement for Linked Answer Question 31 and 32.**

An inductor designed with 400 turns coil wound on an iron core of  $16 \text{ cm}^2$  cross sectional area and with a cut of an air gap length of 1 mm. The coil is connected to a 230 V, 50 Hz ac supply. Neglect coil resistance, core loss, iron reluctance and leakage inductance, ( $\mu_0 = 4\pi \times 10^{-7} \text{ H/M}$ )

**MCQ 2.31**

The current in the inductor is

- (A) 18.08 A
- (B) 9.04 A
- (C) 4.56 A
- (D) 2.28 A

**MCQ 2.32**

The average force on the core to reduce the air gap will be

- (A) 832.29 N
- (B) 1666.22 N
- (C) 3332.47 N
- (D) 6664.84 N





The phasor diagram which is applicable to this circuit is

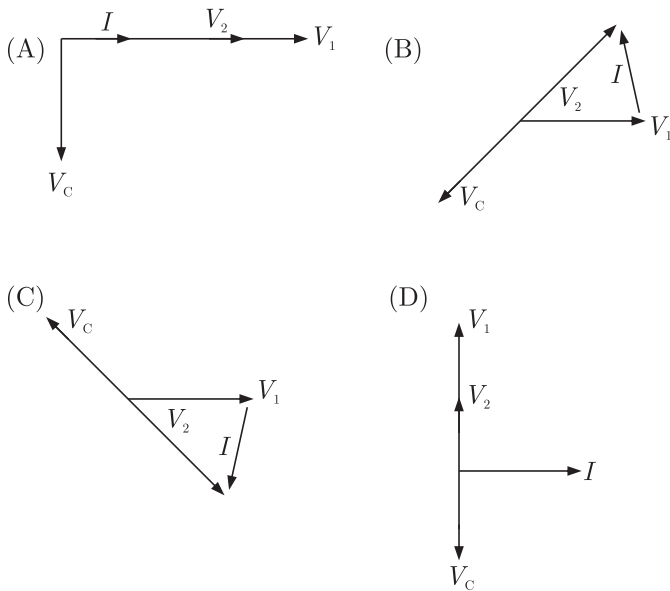

**MCQ 2.38**

An ideal capacitor is charged to a voltage  $V_0$  and connected at  $t = 0$  across an ideal inductor  $L$ . (The circuit now consists of a capacitor and inductor alone). If we let  $\omega_0 = \frac{1}{\sqrt{LC}}$ , the voltage across the capacitor at time  $t > 0$  is given by

- (A)  $V_0$  (B)  $V_0 \cos(\omega_0 t)$   
(C)  $V_0 \sin(\omega_0 t)$  (D)  $V_0 e^{-\omega_0 t} \cos(\omega_0 t)$

**MCQ 2.39**

An energy meter connected to an immersion heater (resistive) operating on an AC 230 V, 50 Hz, AC single phase source reads 2.3 units (kWh) in 1 hour. The heater is removed from the supply and now connected to a 400 V peak square wave source of 150 Hz. The power in kW dissipated by the heater will be

- (A) 3.478 (B) 1.739  
(C) 1.540 (D) 0.870

**MCQ 2.40**

Which of the following statement holds for the divergence of electric and magnetic flux densities ?

**NOTES**

- (A) Both are zero
- (B) These are zero for static densities but non zero for time varying densities.
- (C) It is zero for the electric flux density
- (D) It is zero for the magnetic flux density

**YEAR 2005**

**ONE MARK**

**MCQ 2.41**

In the figure given below the value of  $R$  is

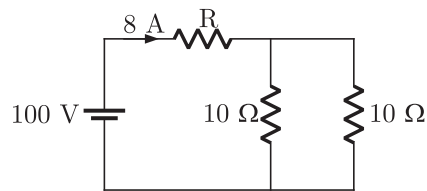

- (A) 2.5  $\Omega$
- (B) 5.0  $\Omega$
- (C) 7.5  $\Omega$
- (D) 10.0  $\Omega$

**MCQ 2.42**

The RMS value of the voltage  $u(t) = 3 + 4 \cos(3t)$  is

- (A)  $\sqrt{17}$  V
- (B) 5 V
- (C) 7 V
- (D)  $(3 + 2\sqrt{2})$  V

**MCQ 2.43**

For the two port network shown in the figure the  $Z$ -matrix is given by

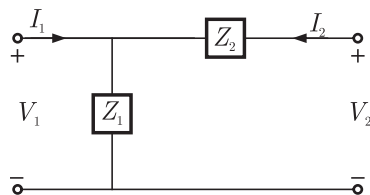

- (A)  $\begin{bmatrix} Z_1 & Z_1 + Z_2 \\ Z_1 + Z_2 & Z_2 \end{bmatrix}$
- (B)  $\begin{bmatrix} Z_1 & Z_1 \\ Z_1 + Z_2 & Z_2 \end{bmatrix}$
- (C)  $\begin{bmatrix} Z_1 & Z_2 \\ Z_2 & Z_1 + Z_2 \end{bmatrix}$
- (D)  $\begin{bmatrix} Z_1 & Z_1 \\ Z_1 & Z_1 + Z_2 \end{bmatrix}$



**NOTES**

**MCQ 2.51**

If, at  $t = 0^+$ , the voltage across the coil is 120 V, the value of resistance  $R$  is

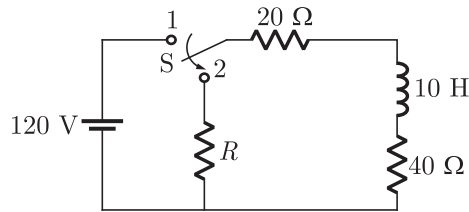

- (A) 0  $\Omega$  (B) 20  $\Omega$   
(C) 40  $\Omega$  (D) 60  $\Omega$

**MCQ 2.52**

For the value as obtained in (a), the time taken for 95% of the stored energy to be dissipated is close to

- (A) 0.10 sec (B) 0.15 sec  
(C) 0.50 sec (D) 1.0 sec

**YEAR 2004**

**ONE MARK**

**MCQ 2.53**

The value of  $Z$  in figure which is most appropriate to cause parallel resonance at 500 Hz is

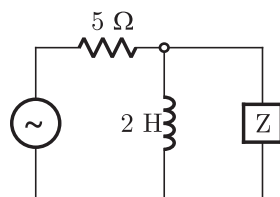

- (A) 125.00 mH (B) 304.20  $\mu\text{F}$   
(C) 2.0  $\mu\text{F}$  (D) 0.05  $\mu\text{F}$

**MCQ 2.54**

A parallel plate capacitor is shown in figure. It is made two square metal plates of 400 mm side. The 14 mm space between the plates is filled with two layers of dielectrics of  $\epsilon_r = 4$ , 6 mm thick and  $\epsilon_r = 2$ , 8

mm thick. Neglecting fringing of fields at the edge the capacitance is

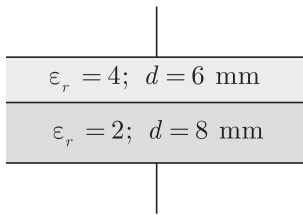

- (A) 1298 pF                                      (B) 944 pF  
(C) 354 pF                                      (D) 257 pF

**MCQ 2.55**

The inductance of a long solenoid of length 1000 mm wound uniformly with 3000 turns on a cylindrical paper tube of 60 mm diameter is

- (A) 3.2  $\mu\text{H}$                                       (B) 3.2 mH  
(C) 32.0 mH                                      (D) 3.2 H

**YEAR 2004**

**TWO MARKS**

**MCQ 2.56**

In figure, the value of the source voltage is

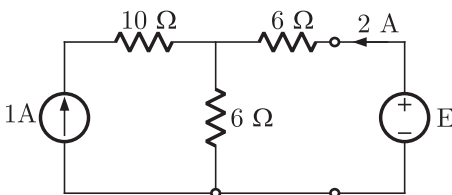

- (A) 12 V    (B) 24 V  
(C) 30 V    (D) 44 V

**MCQ 2.57**

In figure,  $R_a$ ,  $R_b$  and  $R_c$  are  $20 \Omega$ ,  $20 \Omega$  and  $10 \Omega$  respectively. The resistances  $R_1$ ,  $R_2$  and  $R_3$  in  $\Omega$  of an equivalent star-connection are

**NOTES**

**NOTES**

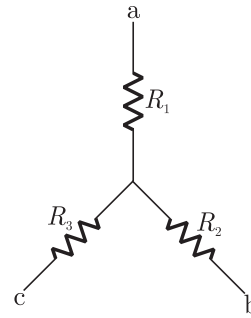
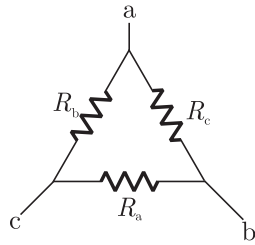

- (A) 2.5, 5, 5
- (C) 5, 5, 2.5

- (B) 5, 2.5, 5
- (D) 2.5, 5, 2.5

**MCQ 2.58**

In figure, the admittance values of the elements in Siemens are  $Y_R = 0.5 + j0$ ,  $Y_L = 0 - j1.5$ ,  $Y_C = 0 + j0.3$  respectively. The value of  $I$  as a phasor when the voltage  $E$  across the elements is  $10\angle 0^\circ$  V

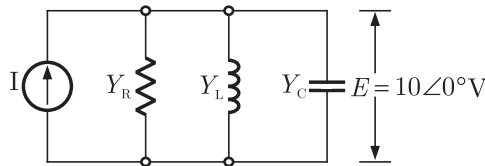

- (A)  $1.5 + j0.5$
- (C)  $0.5 + j1.8$

- (B)  $5 - j18$
- (D)  $5 - j12$

**MCQ 2.59**

In figure, the value of resistance  $R$  in  $\Omega$  is

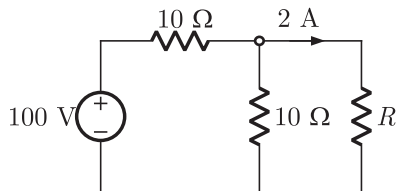

- (A) 10
- (C) 30

- (B) 20
- (D) 40

**MCQ 2.60**

In figure, the capacitor initially has a charge of 10 Coulomb. The

**NOTES**

(A) 144 J

(B) 98 J

(C) 132 J

(D) 168 J

**MCQ 2.64**

A segment of a circuit is shown in figure  $v_R = 5 V$ ,  $v_C = 4 \sin 2t$ . The voltage  $v_L$  is given by

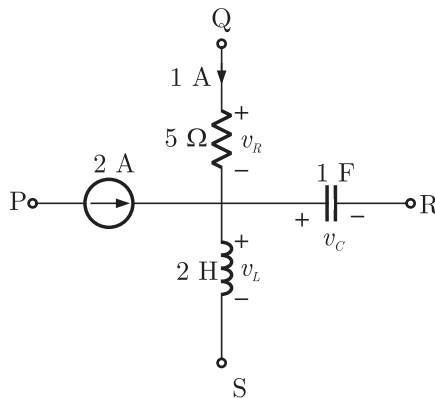

(A)  $3 - 8 \cos 2t$

(B)  $32 \sin 2t$

(C)  $16 \sin 2t$

(D)  $16 \cos 2t$

**MCQ 2.65**

In the figure,  $Z_1 = 10 \angle -60^\circ$ ,  $Z_2 = 10 \angle 60^\circ$ ,  $Z_3 = 50 \angle 53.13^\circ$ . Thevenin impedance seen from X-Y is

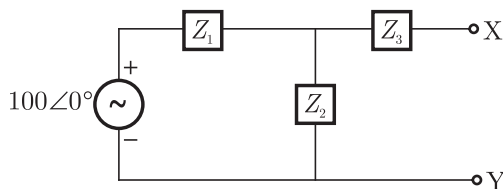

(A)  $56.66 \angle 45^\circ$

(B)  $60 \angle 30^\circ$

(C)  $70 \angle 30^\circ$

(D)  $34.4 \angle 65^\circ$

**MCQ 2.66**

Two conductors are carrying forward and return current of  $+I$  and  $-I$  as shown in figure. The magnetic field intensity  $\vec{H}$  at point P is



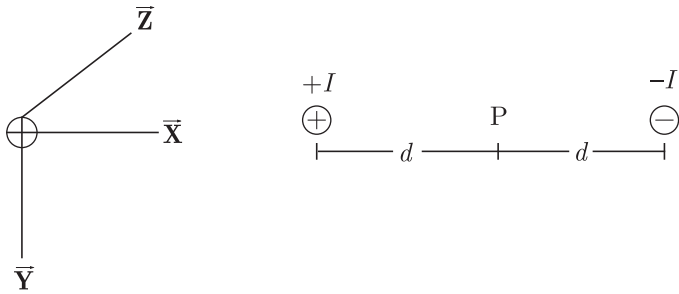

- (A)  $\frac{I}{\pi d} \vec{Y}$                       (B)  $\frac{I}{\pi d} \vec{X}$   
 (C)  $\frac{I}{2\pi d} \vec{Y}$                       (D)  $\frac{I}{2\pi d} \vec{X}$

**MCQ 2.67**

Two infinite strips of width  $w$  m in  $x$ -direction as shown in figure, are carrying forward and return currents of  $+I$  and  $-I$  in the  $z$ -direction. The strips are separated by distance of  $x$  m. The inductance per unit length of the configuration is measured to be  $L$  H/m. If the distance of separation between the strips is now reduced to  $x/2$  m, the inductance per unit length of the configuration is

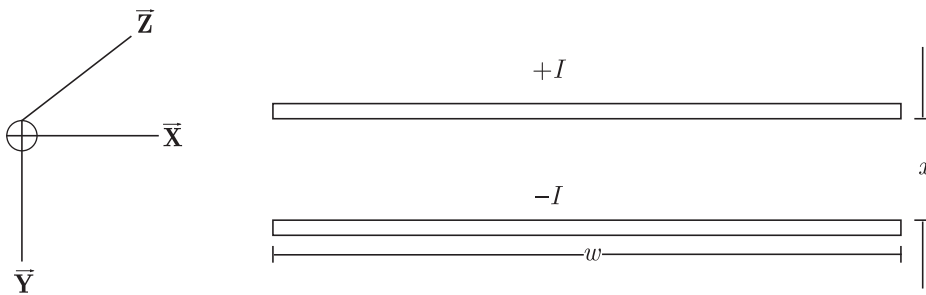

- (A)  $2L$  H/m                      (B)  $L/4$  H/m  
 (C)  $L/2$  H/m                      (D)  $4L$  H/m

**YEAR 2003**

**TWO MARKS**

**MCQ 2.68**

In the circuit of figure, the magnitudes of  $V_L$  and  $V_C$  are twice that of  $V_R$ . Given that  $f = 50$  Hz, the inductance of the coil is







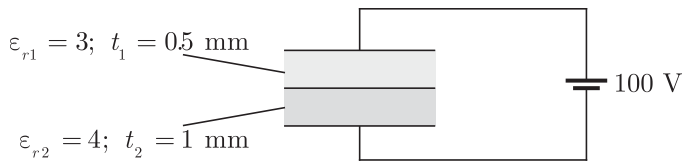

- (A) 52 V (B) 60 V  
(C) 67 V (D) 33 V

YEAR 2002

ONE MARK

**MCQ 2.77**

A current impulse,  $5\delta(t)$ , is forced through a capacitor  $C$ . The voltage,  $v_c(t)$ , across the capacitor is given by

- (A)  $5t$  (B)  $5u(t) - C$   
(C)  $\frac{5}{C}t$  (D)  $\frac{5u(t)}{C}$

**MCQ 2.78**

The graph of an electrical network has  $N$  nodes and  $B$  branches. The number of links  $L$ , with respect to the choice of a tree, is given by

- (A)  $B - N + 1$  (B)  $B + N$   
(C)  $N - B + 1$  (D)  $N - 2B - 1$

**MCQ 2.79**

Given a vector field  $\vec{\mathbf{F}}$ , the divergence theorem states that

- (A)  $\int_S \vec{\mathbf{F}} \cdot d\vec{\mathbf{S}} = \int_V \vec{\nabla} \cdot \vec{\mathbf{F}} dV$   
(B)  $\int_S \vec{\mathbf{F}} \cdot d\vec{\mathbf{S}} = \int_V \vec{\nabla} \times \vec{\mathbf{F}} dV$   
(C)  $\int_S \vec{\mathbf{F}} \times d\vec{\mathbf{S}} = \int_V \vec{\nabla} \cdot \vec{\mathbf{F}} dV$   
(D)  $\int_S \vec{\mathbf{F}} \times d\vec{\mathbf{S}} = \int_V \vec{\nabla} \cdot \vec{\mathbf{F}} dV$

NOTES

- (A) 0.5 mho, 1 mho, 2 mho and 1 mho respectively
- (B)  $\frac{1}{3}$  mho,  $-\frac{1}{6}$  mho,  $-\frac{1}{6}$  mho and  $\frac{1}{3}$  mho respectively
- (C) 0.5 mho, 0.5 mho, 1.5 mho and 2 mho respectively
- (D)  $-\frac{2}{5}$  mho,  $-\frac{3}{7}$  mho,  $\frac{3}{7}$  mho and  $\frac{2}{5}$  mho respectively

**MCQ 2.83**

In the circuit shown in Figure, what value of  $C$  will cause a unity power factor at the ac source ?

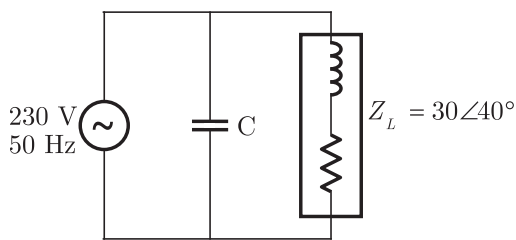

- (A) 68.1  $\mu\text{F}$
- (B) 165  $\mu\text{F}$
- (C) 0.681  $\mu\text{F}$
- (D) 6.81  $\mu\text{F}$

**MCQ 2.84**

A series R-L-C circuit has  $R = 50 \Omega$ ;  $L = 100 \mu\text{H}$  and  $C = 1 \mu\text{F}$ . The lower half power frequency of the circuit is

- (A) 30.55 kHz
- (B) 3.055 kHz
- (C) 51.92 kHz
- (D) 1.92 kHz

**MCQ 2.85**

A 10 V pulse of 10  $\mu\text{s}$  duration is applied to the circuit shown in Figure, assuming that the capacitor is completely discharged prior to applying the pulse, the peak value of the capacitor voltage is

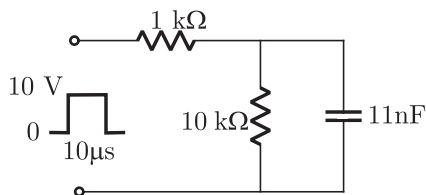

- (A) 11 V
- (B) 5.5 V
- (C) 6.32 V
- (D) 0.96 V







**NOTES**

**MCQ 2.98**

A passive 2-port network is in a steady-state. Compared to its input, the steady state output can never offer

- (A) higher voltage
- (B) lower impedance
- (C) greater power
- (D) better regulation

**YEAR 2001**

**TWO MARKS**

**MCQ 2.99**

Consider the star network shown in Figure The resistance between terminals A and B with C open is  $6 \Omega$ , between terminals B and C with A open is  $11 \Omega$ , and between terminals C and A with B open is  $9 \Omega$ . Then

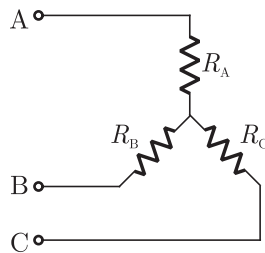

- (A)  $R_A = 4 \Omega, R_B = 2 \Omega, R_C = 5 \Omega$
- (B)  $R_A = 2 \Omega, R_B = 4 \Omega, R_C = 7 \Omega$
- (C)  $R_A = 3 \Omega, R_B = 3 \Omega, R_C = 4 \Omega$
- (D)  $R_A = 5 \Omega, R_B = 1 \Omega, R_C = 10 \Omega$

**MCQ 2.100**

A connected network of  $N > 2$  nodes has at most one branch directly connecting any pair of nodes. The graph of the network

- (A) Must have at least  $N$  branches for one or more closed paths to exist
- (B) Can have an unlimited number of branches
- (C) can only have at most  $N$  branches
- (D) Can have a minimum number of branches not decided by  $N$

**MCQ 2.101**

A 240 V single-phase ac source is connected to a load with an

impedance of  $10 \angle 60^\circ \Omega$ . A capacitor is connected in parallel with the load. If the capacitor supplies 1250 VAR, the real power supplied by the source is

- (A) 3600 W (B) 2880 W  
(C) 240 W (D) 1200 W

**Common Data Questions Q.102-103\*:**

For the circuit shown in figure given values are

$R = 10 \Omega$ ,  $C = 3 \mu\text{F}$ ,  $L_1 = 40 \text{ mH}$ ,  $L_2 = 10 \text{ mH}$  and  $M = 10 \text{ mH}$

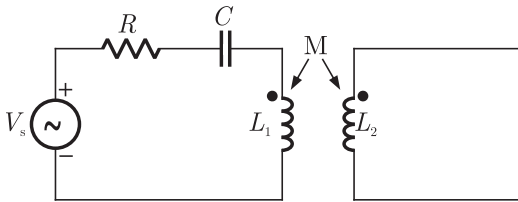

**MCQ 2.102**

The resonant frequency of the circuit is

- (A)  $\frac{1}{3} \times 10^5 \text{ rad/sec}$  (B)  $\frac{1}{2} \times 10^5 \text{ rad/sec}$   
(C)  $\frac{1}{\sqrt{21}} \times 10^5 \text{ rad/sec}$  (D)  $\frac{1}{9} \times 10^5 \text{ rad/sec}$

**MCQ 2.103**

The Q-factor of the circuit in Q.82 is

- (A) 10 (B) 350  
(C) 101 (D) 15

**MCQ 2.104**

Given the potential function in free space to be  $V(x) = (50x^2 + 50y^2 + 50z^2)$  volts, the magnitude (in volts/metre) and the direction of the electric field at a point (1,-1,1), where the dimensions are in metres, are

- (A)  $100; (\hat{i} + \hat{j} + \hat{k})$  (B)  $100/\sqrt{3}; (\hat{i} - \hat{j} + \hat{k})$   
(C)  $100\sqrt{3}; [(-\hat{i} + \hat{j} - \hat{k})/\sqrt{3}]$  (D)  $100\sqrt{3}; [(-\hat{i} - \hat{j} - \hat{k})/\sqrt{3}]$

**NOTES**

**MCQ 2.105**

The hysteresis loop of a magnetic material has an area of  $5 \text{ cm}^2$  with the scales given as  $1 \text{ cm} = 2 \text{ AT}$  and  $1 \text{ cm} = 50 \text{ mWb}$ . At  $50 \text{ Hz}$ , the total hysteresis loss is.

- (A) 15 W (B) 20 W  
(C) 25 W (D) 50 W

**MCQ 2.106**

The conductors of a  $10 \text{ km}$  long, single phase, two wire line are separated by a distance of  $1.5 \text{ m}$ . The diameter of each conductor is  $1 \text{ cm}$ . If the conductors are of copper, the inductance of the circuit is

- (A) 50.0 mH (B) 45.3 mH  
(C) 23.8 mH (D) 19.6 mH

\*\*\*\*\*

## SOLUTION

### SOL 2.1

For  $t < 0$ , the switch was closed for a long time so equivalent circuit is

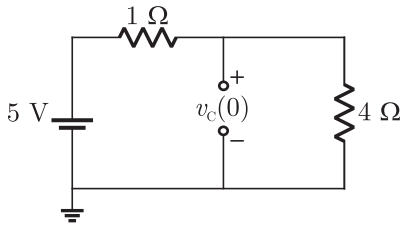

Voltage across capacitor at  $t = 0$

$$v_c(0) = \frac{5}{4 \times 1} = 4 \text{ V}$$

Now switch is opened, so equivalent circuit is

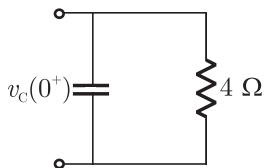

For capacitor at  $t = 0^+$

$$v_c(0^+) = v_c(0) = 4 \text{ V}$$

current in  $4 \Omega$  resistor at  $t = 0^+$ ,  $i_1 = \frac{v_c(0^+)}{4} = 1 \text{ A}$

so current in capacitor at  $t = 0^+$ ,  $i_c(0^+) = i_1 = 1 \text{ A}$

Hence (B) is correct option.

### SOL 2.2

Thevenin equivalent across  $1 \Omega$  resistor can be obtain as following

Open circuit voltage  $v_{th} = 100 \text{ V}$  ( $i = 0$ )

Short circuit current  $i_{sc} = 100 \text{ A}$  ( $v_{th} = 0$ )

So,

$$\begin{aligned} R_{th} &= \frac{v_{th}}{i_{sc}} \\ &= \frac{100}{100} = 1 \Omega \end{aligned}$$

**NOTES**

**SOL 2.6**

Resistance of the bulb rated 200 W/220 V is

$$R_1 = \frac{V^2}{P_1}$$

$$= \frac{(220)^2}{200} = 242 \Omega$$

Resistance of 100 W/220 V lamp is

$$R_T = \frac{V^2}{P_2} = \frac{(220)^2}{100} = 484 \Omega$$

To connect in series

$$R_T = n \times R_1$$

$$484 = n \times 242$$

$$n = 2$$

Hence (D) is correct option.

**SOL 2.7**

For  $t < 0$ ,  $S_1$  is closed and  $S_2$  is opened so the capacitor  $C_1$  will be charged upto 3 volt.

$$V_{C_1}(0) = 3 \text{ Volt}$$

Now when switch positions are changed, by applying charge conservation

$$C_{eq} V_{C_1}(0^+) = C_1 V_{C_1}(0^+) + C_2 V_{C_2}(0^+)$$

$$(2 + 1) \times 3 = 1 \times 3 + 2 \times V_{C_2}(0^+)$$

$$9 = 3 + 2 V_{C_2}(0^+)$$

$$V_{C_2}(0^+) = 3 \text{ Volt}$$

Hence (D) is correct option.

**SOL 2.8**

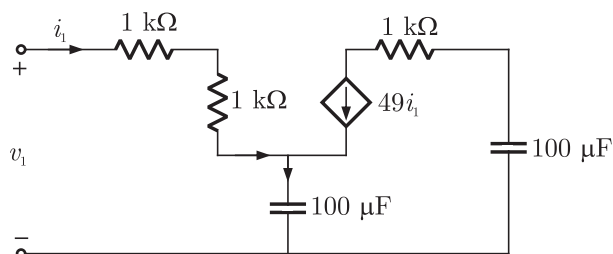

Applying KVL in the input loop

$$v_1 - i_1(1 + 1) \times 10^3 - \frac{1}{j\omega C}(i_1 + 49i_1) = 0$$

$$v_1 = 2 \times 10^3 i_1 + \frac{1}{j\omega C} 50i_1$$

Input impedance

$$\begin{aligned} Z_1 &= \frac{v_1}{i_1} \\ &= 2 \times 10^3 + \frac{1}{j\omega(C/50)} \end{aligned}$$

So, equivalent capacitance

$$C_{eq} = \frac{C}{50} = \frac{100 \mu\text{F}}{50} = 2 \mu\text{F}$$

Hence (A) is correct option.

**SOL 2.9**

Voltage across  $2 \Omega$  resistor,  $V_S = 2 \text{ V}$

$$\text{Current, } I_{2\Omega} = \frac{V_S}{2} = \frac{4}{2} = 2 \text{ A}$$

To make the current double we have to take

$$V_S = 8 \text{ V}$$

Hence (B) is correct option.

**SOL 2.10**

To obtain equivalent thevenin circuit, put a test source between terminals AB

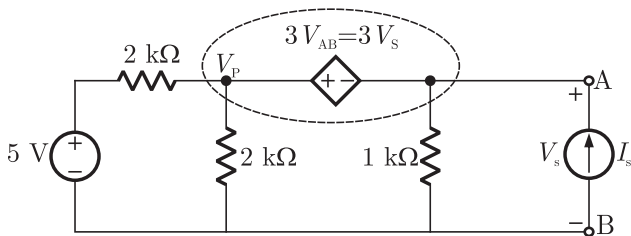

By applying KCL at super node

$$\frac{V_P - 5}{2} + \frac{V_P}{2} + \frac{V_S}{1} = I_S$$

$$V_P - 5 + V_P + 2V_S = 2I_S$$

$$2V_P + 2V_S = 2I_S + 5$$

$$V_P + V_S = I_S + 2.5$$

...(1)

**NOTES**

$$\begin{aligned}
 V_P - V_S &= 3V_S \\
 \Rightarrow V_P &= 4V_S \\
 \text{So, } 4V_S + V_S &= I_S + 2.5 \\
 5V_S &= I_S + 2.5 \\
 V_S &= 0.2I_S + 0.5 \quad \dots(2)
 \end{aligned}$$

For thevenin equivalent circuit

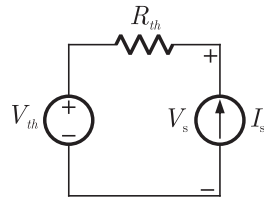

$$V_S = I_S R_{th} + V_{th} \quad \dots(3)$$

By comparing (2) and (3),

Thevenin resistance  $R_{th} = 0.2 \text{ k}\Omega$

Hence (B) is correct option

**SOL 2.11**

From above  $V_{th} = 0.5 \text{ V}$

Hence (D) is correct option.

**SOL 2.12**

No. of chords is given as

$$l = b - n + 1$$

$b \rightarrow$  no. of branches

$n \rightarrow$  no. of nodes

$l \rightarrow$  no. of chords

$b = 6, \quad n = 4$

$$l = 6 - 4 + 1 = 3$$

Hence (A) is correct option.

**SOL 2.13**

Impedance  $Z_o = 2.38 - j0.667 \Omega$

Constant term in impedance indicates that there is a resistance in the circuit.

Assume that only a resistance and capacitor are in the circuit, phase difference in thevenin voltage is given as

$$\theta = -\tan^{-1}(\omega CR) \quad (\text{Due to capacitor})$$

**NOTES**

**SOL 2.15**

Impedance of the circuit is

$$\begin{aligned} Z &= j\omega L + \frac{\frac{1}{j\omega C} R}{\frac{1}{j\omega C} + R} \\ &= j\omega L + \frac{R}{1 + j\omega CR} \times \frac{1 - j\omega CR}{1 - j\omega CR} \\ &= j\omega L + \frac{R(1 - j\omega CR)}{1 + \omega^2 C^2 R^2} \\ &= \frac{j\omega L(1 + \omega^2 C^2 R^2) + R - j\omega CR^2}{1 + \omega^2 C^2 R^2} \\ &= \frac{R}{1 + \omega^2 C^2 R^2} + \frac{j[\omega L(1 + \omega^2 C^2 R^2) - \omega CR^2]}{1 + \omega^2 C^2 R^2} \end{aligned}$$

For resonance  $\text{Im}(Z) = 0$

$$\text{So, } \omega L(1 + \omega^2 C^2 R^2) = \omega CR^2$$

$$L = 0.1 \text{ H, } C = 1 \text{ F, } R = 1 \Omega$$

$$\text{So, } \omega \times 0.1 [1 + \omega^2(1)(1)] = \omega(1)(1)^2$$

$$1 + \omega^2 = 10$$

$$\Rightarrow \omega = \sqrt{9} = 3 \text{ rad/sec}$$

Hence (C) is correct option.

**SOL 2.16**

By applying KVL in the circuit

$$V_{ab} - 2i + 5 = 0$$

$$i = 1 \text{ A,}$$

$$V_{ab} = 2 \times 1 - 5 = -3 \text{ Volt}$$

Hence (A) is correct option.

**SOL 2.17**

By writing node equations at node A and B

$$\frac{V_a - 5}{1} + \frac{V_a - 0}{1} = 0$$

$$2V_a - 5 = 0$$

$$\Rightarrow V_a = 2.5 \text{ V}$$

Similarly

$$\frac{V_b - 4V_{ab}}{3} + \frac{V_b - 0}{1} = 0$$

$$\frac{V_b - 4(V_a - V_b)}{3} + V_b = 0$$



$$V_b - 4(2.5 - V_b) + 3V_b = 0$$

$$8V_b - 10 = 0$$

$$\Rightarrow V_b = 1.25 \text{ V}$$

$$\text{Current } i = \frac{V_b}{1} = 1.25 \text{ A}$$

Hence (B) is correct option.

**SOL 2.18**

Charge stored at  $t = 5 \mu \text{ sec}$

$$Q = \int_0^5 i(t) dt$$

=area under the curve

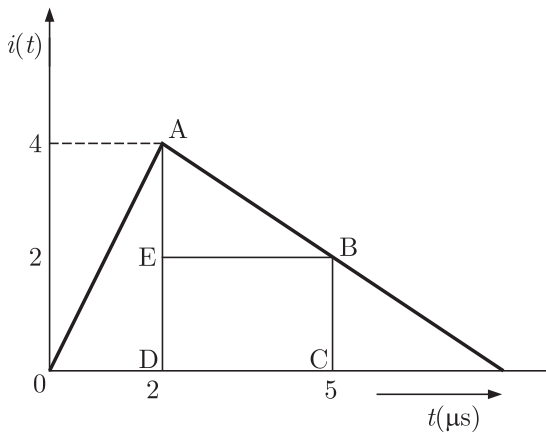

$$\begin{aligned} Q &= \text{Area OABCD} \\ &= \text{Area (OAD)} + \text{Area(AEB)} + \text{Area(EBCD)} \\ &= \frac{1}{2} \times 2 \times 4 + \frac{1}{2} \times 2 \times 3 + 3 \times 2 \\ &= 4 + 3 + 6 \\ &= 13 \text{ nC} \end{aligned}$$

Hence (C) is correct option.

**SOL 2.19**

Initial voltage across capacitor

$$\begin{aligned} V_0 &= \frac{Q_0}{C} = \frac{13 \text{ nC}}{0.3 \text{ nF}} \\ &= 43.33 \text{ Volt} \end{aligned}$$

When capacitor is connected across an inductor it will give sinusoidal response as

**SOL 2.22**

Circumference  $l = 300 \text{ mm}$

no. of turns  $n = 300$

Cross sectional area  $A = 300 \text{ mm}^2$

$$\begin{aligned} \text{Inductance of coil } L &= \frac{\mu_0 n^2 A}{l} \\ &= \frac{4\pi \times 10^{-7} \times (300)^2 \times 300 \times 10^{-6}}{(300 \times 10^{-3})} \\ &= 113.04 \text{ } \mu\text{H} \end{aligned}$$

Hence (B) is correct option.

**SOL 2.23**

Divergence of a vector field is given as

$$\text{Divergence} = \nabla \cdot V$$

In cartesian coordinates

$$\nabla = \frac{\partial}{\partial x} \hat{i} + \frac{\partial}{\partial y} \hat{j} + \frac{\partial}{\partial z} \hat{k}$$

$$\begin{aligned} \text{So } \nabla \cdot V &= \frac{\partial}{\partial x}[-(x \cos xy + y)] + \frac{\partial}{\partial y}[(y \cos xy)] + \\ &\quad \frac{\partial}{\partial z}[(\sin z^2 + x^2 + y^2)] \\ &= -x(-\sin xy)y + y(-\sin xy)x + 2z \cos z^2 \\ &= 2z \cos z^2 \end{aligned}$$

Hence (A) is correct option.

**SOL 2.24**

By writing KVL for both the loops

$$V - 3(I_1 + I_2) - V_x - 0.5 \frac{dI_1}{dt} = 0$$

$$V - 3I_1 - 3I_2 - V_x - 0.5 \frac{dI_1}{dt} = 0 \quad \dots(1)$$

in second loop

$$-5I_2 + 0.2V_x + 0.5 \frac{dI_1}{dt} = 0$$

$$I_2 = 0.04V_x + 0.1 \frac{dI_1}{dt} \quad \dots(2)$$

Put  $I_2$  from eq(2) into eq(1)

$$V - 3I_1 - 3\left[0.04V_x + 0.1 \frac{dI_1}{dt}\right] - V_x - 0.5 \frac{dI_1}{dt} = 0$$

$$\begin{aligned}
 &= \frac{1}{R + j\left(\omega L - \frac{1}{\omega C}\right)} \times \frac{R - j\left(\omega L - \frac{1}{\omega C}\right)}{R - j\left(\omega L - \frac{1}{\omega C}\right)} \\
 &= \frac{R - j\left(\omega L - \frac{1}{\omega C}\right)}{R^2 + \left(\omega L - \frac{1}{\omega C}\right)^2} \\
 &= \frac{R}{R^2 + \left(\omega L - \frac{1}{\omega C}\right)^2} - \frac{j\left(\omega L - \frac{1}{\omega C}\right)}{R^2 + \left(\omega L - \frac{1}{\omega C}\right)^2} \\
 &= \text{Re}(Y) + \text{Im}(Y)
 \end{aligned}$$

By varying frequency for  $\text{Re}(Y)$  and  $\text{Im}(Y)$  we can obtain the admittance-locus.

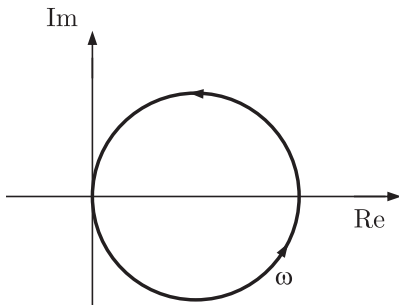

Hence (A) is correct option.

**SOL 2.27**

In the circuit

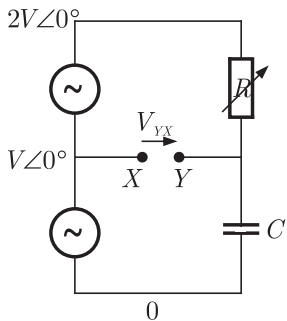

$$V_x = V\angle 0^\circ$$

$$\frac{V_y - 2V\angle 0^\circ}{R} + (V_y)j\omega C = 0$$

**NOTES**

$$V_y(1 + j\omega CR) = 2V \angle 0^\circ$$

$$V_y = \frac{2V \angle 0^\circ}{1 + j\omega CR}$$

$$V_{YX} = V_X - V_Y$$

$$= V - \frac{2V}{1 + j\omega CR}$$

$$R \rightarrow 0, \quad V_{YX} = V - 2V = -V$$

$$R \rightarrow \infty, \quad V_{YX} = V - 0 = V$$

Hence (B) is correct option.

**SOL 2.28**

The circuit is

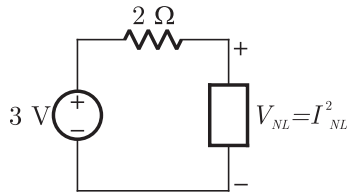

Applying KVL

$$3 - 2 \times I_{NL}^2 = V_{NL}$$

$$3 - 2I_{NL}^2 = I_{NL}^2$$

$$3I_{NL}^2 = 3 \Rightarrow I_{NL} = 1 \text{ A}$$

$$V_{NL} = (1)^2 = 1 \text{ V}$$

So power dissipated in the non-linear resistance

$$P = V_{NL} I_{NL}$$

$$= 1 \times 1 = 1 \text{ W}$$

Hence (A) is correct option.

**SOL 2.29**

In node incidence matrix

$$\begin{matrix} & b_1 & b_2 & b_3 & b_4 & b_5 & b_6 \\ \begin{matrix} n_1 \\ n_2 \\ n_3 \\ n_4 \end{matrix} & \begin{bmatrix} 1 & 1 & 1 & 0 & 0 & 0 \\ 0 & -1 & 0 & -1 & 1 & 0 \\ -1 & 0 & 0 & 0 & -1 & -1 \\ 0 & 0 & -1 & 1 & 0 & 1 \end{bmatrix} \end{matrix}$$

In option (C)

$$E = AV$$

**NOTES**

$$= \frac{4\pi \times 10^{-7} \times (400)^2 \times (16 \times 10^{-4})}{(1 \times 10^{-3})}$$

$$= 321.6 \text{ mH}$$

$$V = IX_L$$

$$= \frac{230}{2\pi fL} \quad \therefore X_L = 2\pi fL$$

$$= \frac{230}{2 \times 3.14 \times 50 \times 321.6 \times 10^{-3}}$$

$$= 2.28 \text{ A}$$

Hence (D) is correct option.

**SOL 2.32**

Energy stored in inductor

$$E = \frac{1}{2} LI^2$$

$$E = \frac{1}{2} \times 321.6 \times 10^{-3} \times (2.28)^2$$

Force required to reduce the air gap of length 1 mm is

$$F = \frac{E}{l} = \frac{0.835}{1 \times 10^{-3}}$$

$$= 835 \text{ N}$$

Hence (A) is correct option.

**SOL 2.33**

Thevenin voltage:

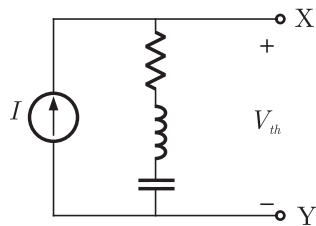

$$V_{th} = I(R + Z_L + Z_C)$$

$$= 1 \angle 0^\circ [1 + 2j - j]$$

$$= 1(1 + j)$$

$$= \sqrt{2} \angle 45^\circ \text{ V}$$

Thevenin impedance:

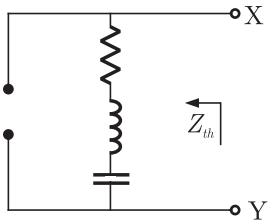

$$\begin{aligned} Z_{th} &= R + Z_L + Z_C \\ &= 1 + 2j - j \\ &= (1 + j) \Omega \end{aligned}$$

Hence (D) is correct option.

**SOL 2.34**

In the given circuit

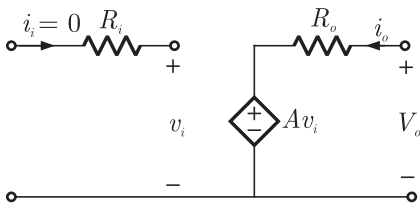

Output voltage

$$\begin{aligned} v_o &= Av_i \\ &= 10^6 \times 1 \mu\text{V} = 1 \text{ V} \end{aligned}$$

Input impedance

$$\begin{aligned} Z_i &= \frac{v_i}{i_i} \\ &= \frac{v_i}{0} = \infty \end{aligned}$$

Output impedance

$$\begin{aligned} Z_o &= \frac{v_o}{i_o} \\ &= \frac{Av_i}{i_o} = R_o \\ &= 10 \Omega \end{aligned}$$

Hence (A) is correct option.

**SOL 2.35**

All sources present in the circuit are DC sources, so all inductors behaves as short circuit and all capacitors as open circuit

Equivalent circuit is

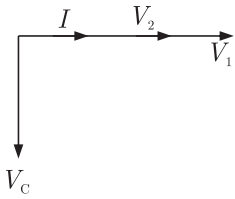

Hence (A) is correct option.

**SOL 2.38**

This is a second order LC circuit shown below

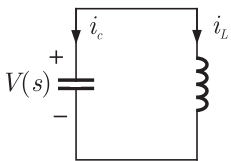

Capacitor current is given as

$$i_C(t) = C \frac{dv_c(t)}{dt}$$

Taking Laplace transform

$$I_C(s) = CsV(s) - V(0), \quad V(0) \rightarrow \text{initial voltage}$$

Current in inductor

$$i_L(t) = \frac{1}{L} \int v_c(t) dt$$

$$I_L(s) = \frac{1}{L} \frac{V(s)}{s}$$

for  $t > 0$ , applying KCL(in s-domain)

$$I_C(s) + I_L(s) = 0$$

$$CsV(s) - V(0) + \frac{1}{L} \frac{V(s)}{s} = 0$$

$$\left[ s^2 + \frac{1}{LCs} \right] V(s) = V_o$$

$$V(s) = V_o \frac{s}{s^2 + \omega_0^2}, \quad \therefore \omega_0^2 = \frac{1}{LC}$$

Taking inverse laplace transformation

$$v(t) = V_o \cos \omega_0 t, \quad t > 0$$

Hence (B) is correct option.

NOTES

**SOL 2.39**

Power dissipated in heater when AC source is connected

$$P = 2.3 \text{ kW} = \frac{V_{rms}^2}{R}$$

$$2.3 \times 10^3 = \frac{(230)^2}{R}$$

$$R = 23 \Omega \text{ (Resistance of heater)}$$

Now it is connected with a square wave source of 400 V peak to peak

Power dissipated is

$$P = \frac{V_{rms}^2}{R}, \quad V_{p-p} = 400 \text{ V} \Rightarrow V_p = 200 \text{ V}$$

$$V_{rms} = V_p = 200 \text{ (for square wave)}$$

So, 
$$P = \frac{(200)^2}{23} = 1.739 \text{ kW}$$

Hence (B) is correct option.

**SOL 2.40**

From maxwell's first equation

$$\nabla \cdot D = \rho_v$$

$$\nabla \cdot E = \frac{\rho_v}{\epsilon}$$

(Divergence of electric field intensity is non-Zero)

Maxwell's fourth equation

$$\nabla \cdot B = 0$$

(Divergence of magnetic field intensity is zero)

Hence (D) is correct option.

**SOL 2.41**

Current in the circuit

$$I = \frac{100}{R + (10 || 10)} = 8 \text{ A} \quad \text{(given)}$$

$$\Rightarrow \frac{100}{R + 5} = 8$$

Or 
$$R = \frac{60}{8} = 7.5 \Omega$$

Hence (C) is correct option.



**SOL 2.42**

Rms value is given as

$$\begin{aligned} \mu_{rms} &= \sqrt{3^2 + \frac{(4)^2}{2}} \\ &= \sqrt{9 + 8} = \sqrt{17} \text{ V} \end{aligned}$$

Hence (A) is correct option.

**SOL 2.43**

By writing KVL in input and output loops

$$\begin{aligned} V_1 - (i_1 + i_2) Z_1 &= 0 \\ V_1 &= Z_1 i_1 + Z_1 i_2 \end{aligned} \quad \dots(1)$$

Similarly

$$\begin{aligned} V_2 - i_2 Z_2 - (i_1 + i_2) Z_1 &= 0 \\ V_2 &= Z_1 i_1 + (Z_1 + Z_2) i_2 \end{aligned} \quad \dots(2)$$

From equation (1) and (2) Z-matrix is given as

$$Z = \begin{bmatrix} Z_1 & Z_1 \\ Z_1 & Z_1 + Z_2 \end{bmatrix}$$

Hence (D) is correct option.

**SOL 2.44**

In final steady state the capacitor will be completely charged and behaves as an open circuit

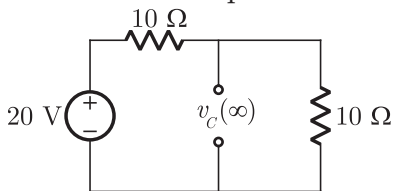

Steady state voltage across capacitor

$$\begin{aligned} v_c(\infty) &= \frac{20}{10 + 10} (10) \\ &= 10 \text{ V} \end{aligned}$$

Hence (B) is correct option.

**SOL 2.45**

We know that divergence of the curl of any vector field is zero

$$\nabla (\nabla \times \vec{E}) = 0$$

Hence (D) is correct option.

**NOTES**

**SOL 2.46**

At  $f_1 = 100$  Hz, voltage drop across  $R$  and  $L$  is  $\mu_{\text{RMS}}$

$$\mu_{\text{RMS}} = \left| \frac{V_{in} \cdot R}{R + j\omega_1 L} \right| = \left| \frac{V_{in}(j\omega_1 L)}{R + j\omega_1 L} \right|$$

So,  $R = \omega_1 L$

at  $f_2 = 50$  Hz, voltage drop across  $R$

$$\mu'_{\text{RMS}} = \left| \frac{V_{in} \cdot R}{R + j\omega_2 L} \right|$$

$$\frac{\mu_{\text{RMS}}}{\mu'_{\text{RMS}}} = \left| \frac{R + j\omega_2 L}{R + j\omega_1 L} \right|$$

$$= \sqrt{\frac{R^2 + \omega_2^2 L^2}{R^2 + \omega_1^2 L^2}}$$

$$= \sqrt{\frac{\omega_1^2 L^2 + \omega_2^2 L^2}{\omega_1^2 L^2 + \omega_1^2 L^2}}, \quad R = \omega_1 L$$

$$= \sqrt{\frac{\omega_1^2 + \omega_2^2}{2\omega_1^2}} = \sqrt{\frac{f_1^2 + f_2^2}{2f_1^2}}$$

$$= \sqrt{\frac{(100)^2 + (50)^2}{2(100)^2}} = \sqrt{\frac{5}{8}}$$

$$\mu'_{\text{RMS}} = \sqrt{\frac{8}{5}} \mu_{\text{RMS}}$$

Hence (C) is correct option

**SOL 2.47**

In the circuit

$$\bar{I}_B = I_R \angle 0^\circ + I_y \angle 120^\circ$$

$$I_B^2 = I_R^2 + I_y^2 + 2I_R I_y \cos\left(\frac{120^\circ}{2}\right)$$

$$I_B^2 = I_R^2 + I_y^2 + I_R I_y$$

$$\therefore I_R = I_y$$

$$\text{so, } I_B^2 = I_R^2 + I_R^2 + I_R^2 = 3I_R^2$$

$$I_B = \sqrt{3} I_R = \sqrt{3} I_y$$

$$I_R : I_y : I_B = 1 : 1 : \sqrt{3}$$

Hence (A) is correct option.

**SOL 2.48**

Switch was opened before  $t = 0$ , so current in inductor for  $t < 0$

$$i(t) = i_1 e^{-\frac{R}{L}t} = 2e^{-\frac{60}{10}t} = 2e^{-6t}$$

After 95% of energy dissipated current remaining in the circuit is

$$i = 2 - 2 \times 0.97 = 0.05 \text{ A}$$

So,  $0.05 = 2e^{-6t}$

$$t \approx 0.50 \text{ sec}$$

Hence (C) is correct option.

**SOL 2.53**

Resonance will occur only when  $Z$  is capacitive, in parallel resonance condition, susceptance of circuit should be zero.

$$\frac{1}{j\omega L} + j\omega C = 0$$

$$1 - \omega^2 LC = 0$$

$$\omega = \frac{1}{\sqrt{LC}} \text{ (resonant frequency)}$$

$$C = \frac{1}{\omega^2 L}$$

$$= \frac{1}{4 \times \pi^2 \times (500)^2 \times 2}$$

$$C = 0.05 \mu\text{F}$$

Hence (D) is correct option.

**SOL 2.54**

Here two capacitor  $C_1$  and  $C_2$  are connected in series so equivalent Capacitance is

$$C_{eq} = \frac{C_1 C_2}{C_1 + C_2}$$

$$C_1 = \frac{\epsilon_0 \epsilon_{r1} A}{d_1} = \frac{8.85 \times 10^{-12} \times 4(400 \times 10^{-3})^2}{6 \times 10^{-3}}$$

$$= \frac{8.85 \times 10^{-12} \times 4 \times 16 \times 10^{-2}}{6 \times 10^{-3}}$$

$$= 94.4 \times 10^{-11} \text{ F}$$

Similarly

$$C_2 = \frac{\epsilon_0 \epsilon_{r2} A}{d_2} = \frac{8.85 \times 10^{-12} \times 2 \times (400 \times 10^{-3})^2}{8 \times 10^{-3}}$$

$$= \frac{8.85 \times 10^{-12} \times 2 \times 16 \times 10^{-2}}{8 \times 10^{-3}}$$

$$= 35.4 \times 10^{-11} \text{ F}$$

$$= \frac{10 \times 10}{20 + 10 + 10} = 2.5 \Omega$$

$$R_2 = \frac{R_a R_c}{R_a + R_b + R_c}$$

$$= \frac{20 \times 10}{20 + 10 + 10} = 5 \Omega$$

$$R_3 = \frac{R_a R_b}{R_a + R_b + R_c}$$

$$= \frac{20 \times 10}{20 + 10 + 10} = 5 \Omega$$

Hence (A) is correct option

**SOL 2.58**

For parallel circuit

$$I = \frac{E}{Z_{eq}} = E Y_{eq}$$

$Y_{eq} \rightarrow$  Equivalent admittance of the circuit

$$Y_{eq} = Y_R + Y_L + Y_C$$

$$= (0.5 + j0) + (0 - j1.5) + (0 + j0.3)$$

$$= 0.5 - j1.2$$

So, current  $I = 10(0.5 - j1.2)$

$$= (5 - j12) \text{ A}$$

Hence (D) is correct option.

**SOL 2.59**

In the circuit

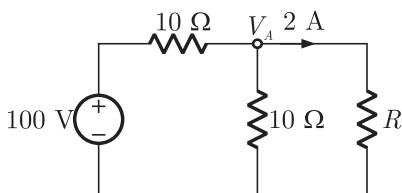

Voltage  $V_A = \frac{100}{10 + (10 || R)} \times (10 || R)$

$$= \left( \frac{100}{10 + \frac{10R}{10 + R}} \right) \left( \frac{10R}{10 + R} \right)$$

$$= \frac{1000R}{100 + 20R}$$

**NOTES**

$$= \frac{50R}{5 + R}$$

Current in  $R \Omega$  resistor

$$2 = \frac{V_A}{R}$$

$$2 = \frac{50R}{R(5 + R)}$$

Or  $R = 20 \Omega$

Hence (B) is correct option.

**SOL 2.60**

Since capacitor initially has a charge of 10 coulomb, therefore

$$Q_0 = Cv_c(0) \quad v_c(0) \rightarrow \text{initial voltage across capacitor}$$

$$10 = 0.5v_c(0)$$

$$v_c(0) = \frac{10}{0.5} = 20 \text{ V}$$

When switch  $S$  is closed, in steady state capacitor will be charged completely and capacitor voltage is

$$v_c(\infty) = 100 \text{ V}$$

At any time  $t$  transient response is

$$v_c(t) = v_c(\infty) + [v_c(0) - v_c(\infty)] e^{-\frac{t}{RC}}$$

$$\begin{aligned} v_c(t) &= 100 + (20 - 100) e^{-\frac{t}{2 \times 0.5}} \\ &= 100 - 80e^{-t} \end{aligned}$$

Current in the circuit

$$i(t) = C \frac{dv_c}{dt}$$

$$i(t) = C \frac{d}{dt} [100 - 80e^{-t}]$$

$$= C \times 80e^{-t}$$

$$= 0.5 \times 80e^{-t}$$

$$= 40e^{-t}$$

at  $t = 1$  sec,

$$i(t) = 40e^{-1}$$

$$= 14.71 \text{ A}$$

Hence (A) is correct option

**SOL 2.61**

Total current in the wire

$$I = 10 + 20 \sin \omega t$$

**SOL 2.65**

Thevenin impedance can be obtain as following

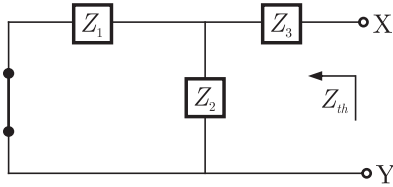

$$Z_{th} = Z_3 + (Z_1 || Z_2)$$

given that  $Z_1 = 10 \angle -60^\circ = 10 \left( \frac{1 - \sqrt{3}j}{2} \right)$   
 $= 5(1 - \sqrt{3}j)$

$$Z_2 = 10 \angle 60^\circ$$

$$= 10 \left( \frac{1 + \sqrt{3}j}{2} \right)$$

$$= 5(1 + \sqrt{3}j)$$

$$Z_3 = 50 \angle 53.13^\circ$$

$$= 50 \left( \frac{3 + 4j}{5} \right)$$

$$= 10(3 + 4j)$$

So,

$$Z_{th} = 10(3 + 4j) + \frac{5(1 - 3j)5(1 + \sqrt{3}j)}{5(1 - \sqrt{3}j) + 5(1 + \sqrt{3}j)}$$

$$= 10(3 + 4j) + \frac{25(1 + 3)}{10}$$

$$= 30 + 40j + 10$$

$$= 40 + 40j$$

$$Z_{th} = 40\sqrt{2} \angle 45^\circ \Omega$$

Hence (A) is correct option.

**SOL 2.66**

Due to the first conductor carrying  $+I$  current, magnetic field intensity at point P is

$$\vec{H}_1 = \frac{I}{2\pi d} \vec{Y} \text{ (Direction is determined using right hand rule)}$$

Similarly due to second conductor carrying  $-I$  current, magnetic field intensity is

$$\vec{H}_2 = \frac{-I}{2\pi d} (-\vec{Y})$$

**NOTES**

$$= \frac{I}{2\pi d} \vec{Y}$$

Total magnetic field intensity at point P.

$$\begin{aligned} \vec{H} &= \vec{H}_1 + \vec{H}_2 \\ &= \frac{I}{2\pi d} \vec{Y} + \frac{I}{2\pi d} \vec{Y} \\ &= \frac{I}{\pi d} \vec{Y} \end{aligned}$$

Hence (A) is correct option.

**SOL 2.67**

**SOL 2.68**

Given that magnitudes of  $V_L$  and  $V_C$  are twice of  $V_R$

$$|V_L| = |V_C| = 2V_R \quad (\text{Circuit is at resonance})$$

Voltage across inductor

$$V_L = i_R \times j\omega L$$

Current  $i_R$  at resonance

$$i_R = \frac{5 \angle 0^\circ}{R} = \frac{5}{5} = 1 \text{ A}$$

so,

$$|V_L| = \omega L = 2V_R$$

$$\omega L = 2 \times 5 \quad V_R = 5 \text{ V, at resonance}$$

$$2 \times \pi \times 50 \times L = 10$$

$$L = \frac{10}{314} = 31.8 \text{ mH}$$

Hence (C) is correct option.

**SOL 2.69**

Applying nodal analysis in the circuit

At node P

$$2 + \frac{V_P - 10}{2} + \frac{V_P}{8} = 0$$

$$16 + 4V_P - 40 + V_P = 0$$

$$5V_P - 24 = 0$$

$$\Rightarrow V_P = \frac{24}{5} \text{ Volt}$$

At node Q

$$2 = \frac{V_Q - 10}{4} + \frac{V_Q - 0}{6}$$

$$24 = 3V_Q - 30 + 2V_Q$$

$$5V_Q - 54 = 0$$

$$\Rightarrow V_Q = \frac{54}{5} \text{ V}$$

Potential difference between P-Q

$$\begin{aligned} V_{PQ} &= V_P - V_Q \\ &= \frac{24}{5} - \frac{54}{5} = -6 \text{ V} \end{aligned}$$

Hence (C) is correct option.

**SOL 2.70**

First obtain equivalent Thevenin circuit across load  $R_L$

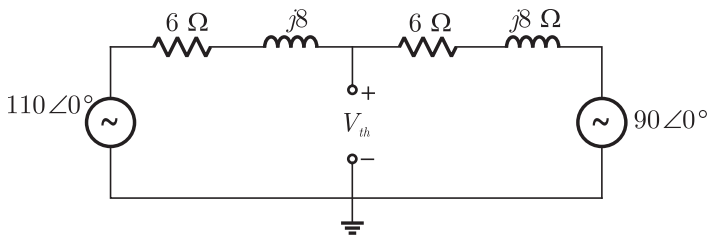

Thevenin voltage

$$\frac{V_{th} - 110\angle 0^\circ}{6 + 8j} + \frac{V_{th} - 90\angle 0^\circ}{6 + 8j} = 0$$

$$2V_{th} - 200\angle 0^\circ = 0$$

$$\Rightarrow V_{th} = 100\angle 0^\circ \text{ V}$$

Thevenin impedance

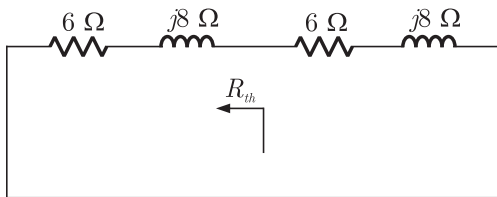

$$\begin{aligned} Z_{th} &= (6 + 8j)\Omega \parallel (6 + 8j)\Omega \\ &= (3 + 4j)\Omega \end{aligned}$$

For maximum power transfer

$$R_L = |Z_{th}| = \sqrt{3^2 + 4^2} = 5\Omega$$

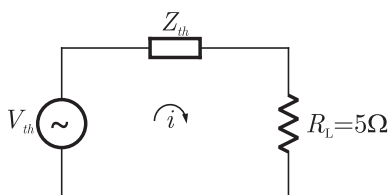



**NOTES**

At node A

$$\frac{E_A - E_1}{2} + \frac{E_A - E_2}{2} + \frac{E_A}{4} = 0$$

$$5E_A = 2E_1 + 2E_2 \quad \dots(1)$$

Similarly

$$\frac{E_1 - E_A}{2} + \frac{E_1}{2} = 0$$

$$2E_1 = E_A \quad \dots(2)$$

From (1) and (2)

$$5(2E_1) = 2E_1 + 2E_2$$

$$8E_1 = 2E_2$$

$$h_{12} = \frac{E_1}{E_2} = \frac{1}{4}$$

Hence (D) is correct option.

**SOL 2.74**

$$V_{PQ} = V_P - V_Q$$

$$= \frac{KQ}{OP} - \frac{KQ}{OQ}$$

$$= \frac{9 \times 10^9 \times 1 \times 10^{-9}}{40 \times 10^{-3}} - \frac{9 \times 10^9 \times 1 \times 10^{-9}}{20 \times 10^{-3}}$$

$$= 9 \times 10^3 \left[ \frac{1}{40} - \frac{1}{20} \right] = -225 \text{ Volt}$$

Hence (B) is correct option

**SOL 2.75**

Energy stored in Capacitor is

$$E = \frac{1}{2} CV^2$$

$$C = \frac{\epsilon_0 A}{d}$$

$$= \frac{8.85 \times 10^{-12} \times 100 \times 10^{-6}}{0.1 \times 10^{-3}}$$

$$= 8.85 \times 10^{-12} \text{ F}$$

$$E = \frac{1}{2} \times 8.85 \times 10^{-12} \times (100)^2$$

$$= 44.3 \text{ nJ}$$

Hence (D) is correct option.

**SOL 2.76**

The figure is as shown below

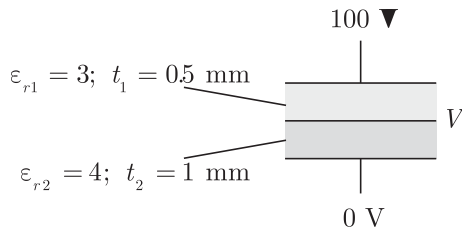

The Capacitor shown in Figure is made up of two capacitor  $C_1$  and  $C_2$  connected in series.

$$C_1 = \frac{\epsilon_0 \epsilon_{r1} A}{t_1}, C_2 = \frac{\epsilon_0 \epsilon_{r2} A}{t_2}$$

Since  $C_1$  and  $C_2$  are in series charge on both capacitor is same.

$$Q_1 = Q_2$$

$$C_1(100 - V) = C_2 V \text{ (Let } V \text{ is the voltage of foil)}$$

$$\frac{\epsilon_0 \epsilon_{r1} A}{t_1} (100 - V) = \frac{\epsilon_0 \epsilon_{r2} A}{t_2} V$$

$$\frac{3}{0.5} (100 - V) = \frac{4}{1} V$$

$$300 - 3V = 2V$$

$$300 = 5V \Rightarrow V = 60 \text{ Volt}$$

Hence (B) is correct option.

**SOL 2.77**

Voltage across capacitor is given by

$$\begin{aligned} v_c(t) &= \frac{1}{C} \int_{-\infty}^{\infty} i(t) dt \\ &= \frac{1}{C} \int_{-\infty}^{\infty} 5\delta(t) dt = \frac{5}{C} \times u(t) \end{aligned}$$

Hence (D) is correct option.

**SOL 2.78**

No. of links is given by

$$L = N - B + 1$$

Hence (C) is correct option.

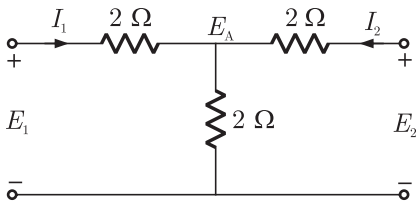

$$I_1 = \frac{E_1 - E_A}{2}$$

and  $I_2 = \frac{E_2 - E_A}{2}$

At node A

$$\frac{E_A - E_1}{2} + \frac{E_A}{2} + \frac{E_A - E_2}{2} = 0$$

$$3E_A = E_1 + E_2 \quad \dots(1)$$

From eqn(1)

$$I_1 = \frac{1}{2}E_1 - \frac{1}{2} \frac{(E_1 + E_2)}{3}$$

$$I_1 = \frac{1}{3}E_1 - \frac{1}{6}E_2 \quad \dots(2)$$

Similarly

$$I_2 = \frac{1}{2}E_2 - \frac{1}{2} \frac{(E_1 + E_2)}{3}$$

$$I_2 = -\frac{1}{6}E_1 + \frac{1}{3}E_2 \quad \dots(3)$$

From (2) and (3) admittance parameters are

$$[Y_{11} \ Y_{12} \ Y_{21} \ Y_{22}] = [1/3 \ -1/6 \ -1/6 \ 1/3]$$

Hence (B) is correct option.

**SOL 2.83**

Admittance of the given circuit

$$Y(\omega) = j\omega C + \frac{1}{Z_L}$$

$$Z_L = 30 \angle 40^\circ = 23.1 + j19.2 \Omega$$

So, 
$$Y(\omega) = j2\pi \times 50 \times C + \frac{1}{23.1 + j19.2} \times \frac{23.1 - j19.2}{23.1 - j19.2}$$

$$= j(100\pi) C + \frac{23.1 - j19.2}{902.25}$$

$$= \frac{23.1}{902.25} + j \left[ (100\pi) C - \frac{19.2}{902.25} \right]$$

For unity power factor

$$I_m[Y(\omega)] = 0$$

**NOTES**

**NOTES**

$$100 \times 3.14 \times C = \frac{19.2}{902.25}$$

$$C \simeq 68.1 \mu\text{F}$$

Hence (A) is correct option.

**SOL 2.84**

In series RLC circuit lower half power frequency is given by following relations

$$\omega_1 L - \frac{1}{\omega_1 C} = -R$$

$$(2\pi \times f_1 \times 100 \times 10^{-6}) - \frac{1}{2\pi \times f_1 (1 \times 10^{-6})} = -50$$

$$f_1 = 3.055 \text{ kHz}$$

Hence (B) is correct option.

**SOL 2.85**

Since initial charge across capacitor is zero, voltage across capacitor at any time  $t$  is given as

$$v_c(t) = 10(1 - e^{-\frac{t}{\tau}})$$

Time constant

$$\tau = R_{eq} C$$

$$\tau = (10 \text{ k}\Omega \parallel 1 \text{ k}\Omega) \times C$$

$$= \left(\frac{10}{11}\right) \text{ k}\Omega \times 11 \text{ nF}$$

$$= 10 \times 10^{-6} \text{ sec}$$

$$= 10 \mu\text{sec}$$

So, 
$$v_c(t) = 10(1 - e^{-\frac{t}{10 \mu\text{sec}}})$$

Pulse duration is  $10 \mu\text{sec}$ , so voltage across capacitor will be maximum at  $t = 10 \mu\text{sec}$

$$v_c(t = 10 \mu\text{sec}) = 10(1 - e^{-\frac{10 \mu\text{sec}}{10 \mu\text{sec}}})$$

$$= 10(1 - e^{-1})$$

$$= 6.32 \text{ Volt}$$

Hence (C) is correct option.

**SOL 2.86**

Since voltage and current are in phase so equivalent inductance is

$$L_{eq} = 12 \text{ H}$$

$$L_1 + L_2 \pm 2M = 12 \quad M \rightarrow \text{Mutual Inductance}$$

$$8 + 8 \pm 2M = 12$$

$$16 - 2M = 12 \quad (\text{Dot is at position } Q)$$

$$M = 2 \text{ H}$$

Coupling Coefficient

$$K = \frac{2}{\sqrt{8 \times 8}}$$

$$= 0.25$$

Hence (C) is correct option.

**SOL 2.87**

**SOL 2.88**

In steady state there is no voltage drop across inductor (i.e. it is short circuit) and no current flows through capacitors (i.e. it is open circuit)

The equivalent circuit is

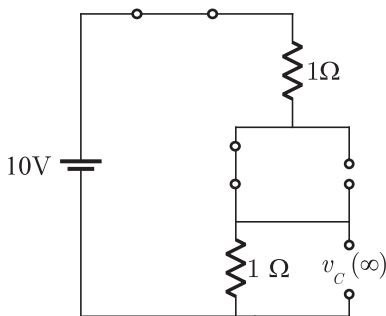

$$\text{So, } v_c(\infty) = \frac{10}{1+1} \times 1 = 5 \text{ Volt}$$

Hence (C) is correct option

**SOL 2.89**

When the switch was closed before  $t = 0$ , the circuit is

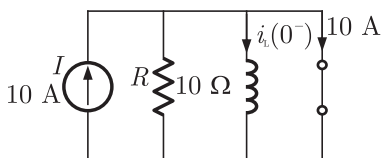

Current in the inductor

$$i_L(0^-) = 0 \text{ A}$$

When the switch was opened at  $t = 0$ , equivalent circuit is

**NOTES**

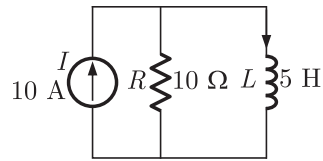

In steady state, inductor behaves as short circuit and 10 A current flows through it

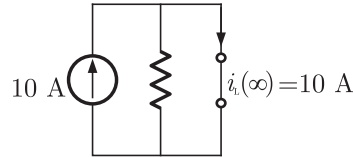

$$i_L(\infty) = 10 \text{ A}$$

Inductor current at any time  $t$  is given by

$$\begin{aligned} i_L(t) &= i_L(\infty) + [i_L(0) - i_L(\infty)]e^{-\frac{R}{L}t} \\ &= 10 + (0 - 10)e^{-\frac{5}{10}t} \\ &= 10(1 - e^{-2t}) \text{ A} \end{aligned}$$

Hence (C) is correct option.

**SOL 2.90**

Energy stored in inductor is

$$E = \frac{1}{2}Li^2 = \frac{1}{2} \times 5 \times (10)^2 = 250 \text{ J}$$

Hence (B) is correct option.

**SOL 2.91**

To obtain thevenin's equivalent, open the terminals  $X$  and  $Y$  as shown below,

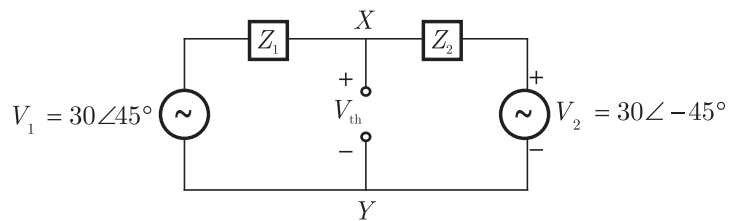

By writing node equation at  $X$

$$\frac{V_{th} - V_1}{Z_1} + \frac{V_{th} - V_2}{Z_2} = 0$$

**NOTES**

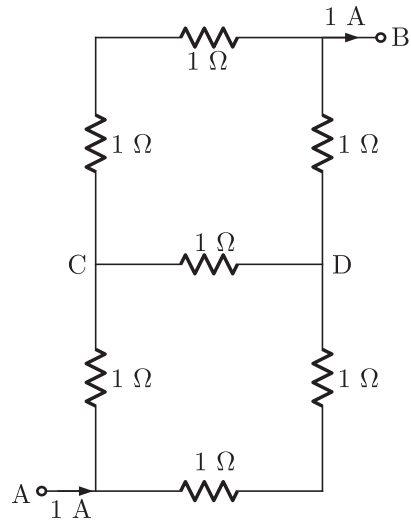

We can draw the circuit as

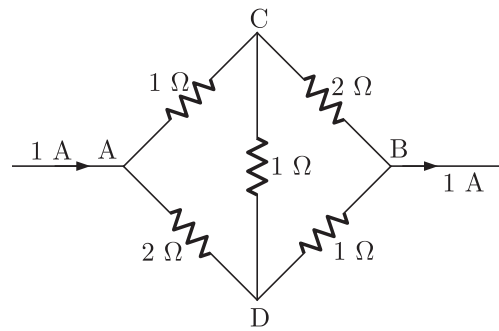

From  $\Delta - Y$  conversion

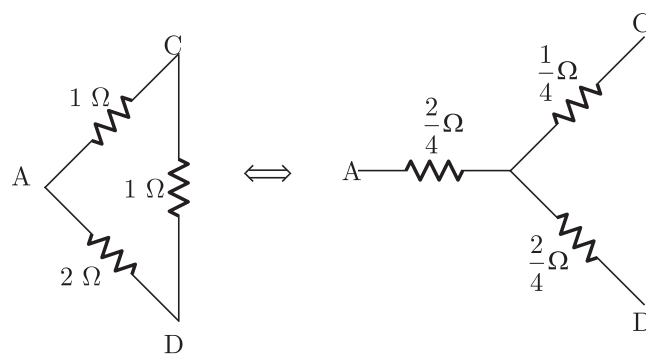

Now the circuit is

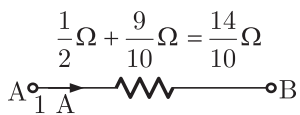
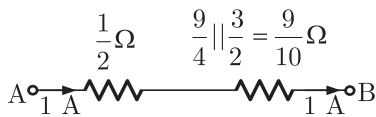
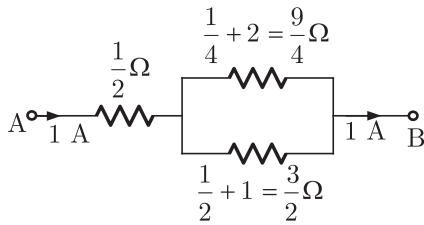
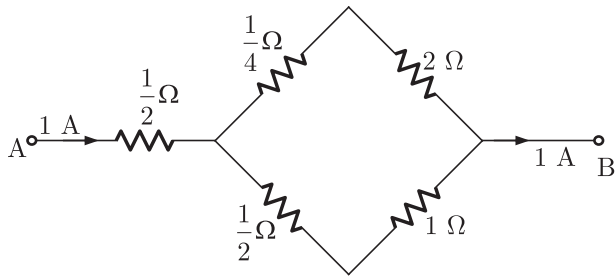

$$V_{AB} = 1 \times \frac{14}{10} = 1.4 \text{ Volt}$$

Hence (A) is correct option.

**SOL 2.94**

In a series RLC circuit, at resonance, current is given as

$$i = \frac{V_s \angle 0^\circ}{R}, \quad V_s \rightarrow \text{source voltage}$$

So, voltage across capacitor at resonance

$$V_c = \frac{1}{j\omega C} \times \frac{V_s \angle 0^\circ}{R}$$

$$V_c = \frac{V_s}{\omega CR} \angle -90^\circ$$

Voltage across capacitor can be greater than input voltage depending upon values of  $\omega$ ,  $C$  and  $R$  but it is  $90^\circ$  out of phase with the input

Hence (C) is correct option.



$$0 < K \leq 1$$

$$\text{So, } K = \frac{M}{\sqrt{L_1 L_2}} \leq 1$$

$$M \leq \sqrt{L_1 L_2}$$

Hence (D) is correct option.

**SOL 2.98**

Since the network contains passive elements only, output can never offer greater power compared to input

Hence (C) is correct option.

**SOL 2.99**

Given that

When terminal  $C$  is open

$$R_{AB} = R_A + R_B = 6 \Omega \quad \dots(1)$$

When terminal  $A$  is open

$$R_{BC} = R_B + R_C = 11 \Omega \quad \dots(2)$$

When terminal  $B$  is open

$$R_{AC} = R_A + R_C = 9 \Omega \quad (3)$$

From (1), (2) and (3)

$$R_A = 2 \Omega, R_B = 4 \Omega, R_C = 7 \Omega$$

Hence (B) is correct option.

**SOL 2.100**

A graph is connected if there exist at least one path between any two vertices (nodes) of the network. So it should have at least  $N$  or more branches for one or more closed paths to exist.

Hence ( ) is correct option.

**SOL 2.101**

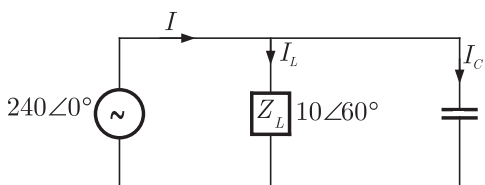

Current  $I_L = \frac{240 \angle 0^\circ}{10 \angle 60^\circ}$

**NOTES**

$$\begin{aligned}
 &= 24 \angle -60^\circ \\
 &= \frac{24(1 - \sqrt{3}j)}{2} \text{ A} \\
 &= 12 - j20.784 \text{ A} \\
 I_c &= \frac{P}{V} = \frac{j1250}{240 \angle 0^\circ} = j5.20 \angle 0^\circ \text{ A}
 \end{aligned}$$

Current

$$\begin{aligned}
 I &= I_C + I_L \\
 &= 12 - j20.784 + j5.20 \\
 &= 12 - j15.58
 \end{aligned}$$

Power supplied by load

$$\begin{aligned}
 P &= VI \\
 &= 240(12 - j15.58) \\
 &= 2880 - 3739j
 \end{aligned}$$

Real power  $P_R = 2880 \text{ W}$

Hence (B) is correct option

**SOL 2.102**

Let current in primary and secondary loop is  $I_1$  and  $I_2$  respectively, then by writing KVL equation (considering mutual inductance),

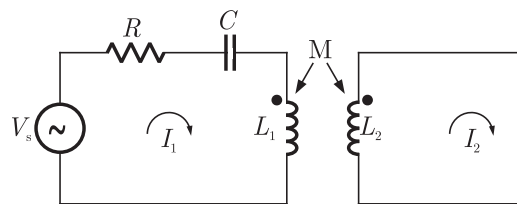

In primary loop

$$V_s - I_1 R - I_1 \left( \frac{1}{j\omega C} \right) - I_1 j\omega L_1 - I_2 j\omega M = 0$$

$$V_s = I_1 \left[ R + \frac{1}{j\omega C} + j\omega L_1 \right] + j\omega M I_2 \quad \dots(1)$$

In secondary loop

$$0 - I_2 j\omega L_2 - I_1 j\omega M = 0$$

$$I_2 L_2 + I_1 M = 0$$

$$I_2 = -\frac{M}{L_2} I_1$$

Put  $I_2$  into equation (1)

$$V_s = I_1 \left[ R + \frac{1}{j\omega C} + j\omega L_1 \right] + j\omega M \left( -\frac{M}{L_2} \right) I_1 = 0$$

**NOTES**

**SOL 2.104**

Voltage and electric field are related as

$$\begin{aligned}
 E &= -\nabla V && \text{(Gradient of } V) \\
 &= -\left[ \frac{\partial V_x}{\partial x} \hat{i} + \frac{\partial V_y}{\partial y} \hat{j} + \frac{\partial V_z}{\partial z} \hat{k} \right] \\
 &= -\left[ \frac{\partial (50x^2)}{\partial x} \hat{i} + \frac{\partial (50y^2)}{\partial y} \hat{j} + \frac{\partial (50z^2)}{\partial z} \hat{k} \right] \\
 &= -[100x \hat{i} + 100y \hat{j} + 100z \hat{k}]
 \end{aligned}$$

$$\begin{aligned}
 E(1, -1, 1) &= -[100\hat{i} - 100\hat{j} + 100\hat{k}] \\
 &= -100\hat{i} + 100\hat{j} - 100\hat{k}
 \end{aligned}$$

$$E(1, -1, 1) = 100\sqrt{3} \left[ \frac{-\hat{i} + \hat{j} - \hat{k}}{\sqrt{3}} \right]$$

Hence (C) is correct option.

**SOL 2.105**

Power loss in watt is given as

$$P_h = W_h Vf$$

Where

$W_h \rightarrow$  Energy Density Loss

$V \rightarrow$  Volume of Material

Here

$$\begin{aligned}
 W_h V &= \text{Area of hysteresis loop} \\
 &= 5 \text{ cm}^2
 \end{aligned}$$

So,

$$\begin{aligned}
 P_h &= 5 \text{ cm}^2 \times 50 \\
 &= 5 \times 2 \times 50 \times 10^{-3} \times 50 = 25 \text{ Watt}
 \end{aligned}$$

Hence (C) is correct option.

**SOL 2.106**

For two parallel wires inductance is

$$L = \frac{\mu_0 l}{\pi} \ln\left(\frac{d}{r}\right)$$

$l \rightarrow$  Length of the wires

$d \rightarrow$  Distance between the wires

$r \rightarrow$  Radius Thus

$$\begin{aligned}
 L &= \frac{4\pi \times 10^{-7} \times 10 \times 10^3}{\pi} \ln\left(\frac{1.5}{0.5 \times 10^{-2}}\right) \\
 &= 4 \times 10^{-3} \ln(300) = 22.81 \text{ mH}
 \end{aligned}$$

Hence (C) is correct option.

\*\*\*\*\*



(A)  $h[n] = \{1, 0, 0, 1\}$   
 $\uparrow$

(B)  $h[n] = \{1, 0, 1\}$   
 $\uparrow$

(C)  $h[n] = \{1, 1, 1, 1\}$   
 $\uparrow$

(D)  $h[n] = \{1, 1, 1\}$   
 $\uparrow$

**Common Data Questions Q.6-7.**

Given  $f(t)$  and  $g(t)$  as show below

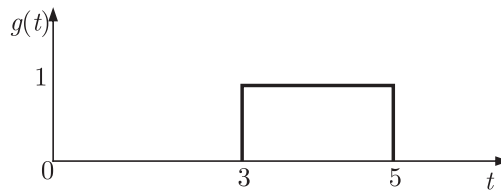
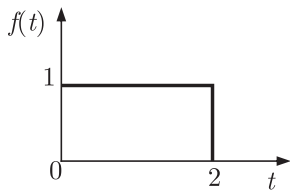

**MCQ 3.7**

$g(t)$  can be expressed as

(A)  $g(t) = f(2t - 3)$

(B)  $g(t) = f\left(\frac{t}{2} - 3\right)$

(C)  $g(t) = f\left(2t - \frac{3}{2}\right)$

(D)  $g(t) = f\left(\frac{t}{2} - \frac{3}{2}\right)$

**MCQ 3.8**

The Laplace transform of  $g(t)$  is

(A)  $\frac{1}{s}(e^{3s} - e^{5s})$

(B)  $\frac{1}{s}(e^{-5s} - e^{-3s})$

(C)  $\frac{e^{-3s}}{s}(1 - e^{-2s})$

(D)  $\frac{1}{s}(e^{5s} - e^{3s})$

**YEAR 2009**

**ONE MARK**

**MCQ 3.9**

A Linear Time Invariant system with an impulse response  $h(t)$  produces output  $y(t)$  when input  $x(t)$  is applied. When the input  $x(t - \tau)$  is applied to a system with impulse response  $h(t - \tau)$ , the output will be

(A)  $y(\tau)$

(B)  $y(2(t - \tau))$

(C)  $y(t - \tau)$

(D)  $y(t - 2\tau)$

**MCQ 3.10**

A cascade of three Linear Time Invariant systems is causal and unstable. From this, we conclude that

- (A) each system in the cascade is individually causal and unstable
- (B) at least one system is unstable and at least one system is causal
- (C) at least one system is causal and all systems are unstable
- (D) the majority are unstable and the majority are causal

**MCQ 3.11**

The Fourier Series coefficients of a periodic signal  $x(t)$  expressed as  $x(t) = \sum_{k=-\infty}^{\infty} a_k e^{j2\pi kt/T}$  are given by  $a_2 = 2 - j1$ ,  $a_{-1} = 0.5 + j0.2$ ,  $a_0 = j2$ ,  $a_1 = 0.5 - j0.2$ ,  $a_2 = 2 + j1$  and  $a_k = 0$  for  $|k| > 2$

Which of the following is true ?

- (A)  $x(t)$  has finite energy because only finitely many coefficients are non-zero
- (B)  $x(t)$  has zero average value because it is periodic
- (C) The imaginary part of  $x(t)$  is constant
- (D) The real part of  $x(t)$  is even

**MCQ 3.12**

The z-transform of a signal  $x[n]$  is given by  $4z^{-3} + 3z^{-1} + 2 - 6z^2 + 2z^3$

It is applied to a system, with a transfer function  $H(z) = 3z^{-1} - 2$

Let the output be  $y[n]$ . Which of the following is true ?

- (A)  $y[n]$  is non causal with finite support
- (B)  $y[n]$  is causal with infinite support
- (C)  $y[n] = 0; |n| > 3$
- (D)  $\text{Re}[Y(z)]_{z=e^{j\theta}} = -\text{Re}[Y(z)]_{z=e^{-j\theta}}$   
 $\text{Im}[Y(z)]_{z=e^{j\theta}} = \text{Im}[Y(z)]_{z=e^{-j\theta}}; -\pi \leq \theta < \pi$

**MCQ 3.13**

The impulse response of a causal linear time-invariant system is given

**NOTES**

minimum of  $\alpha$  and  $\beta$  and similarly,  $\max(\alpha, \beta)$  denotes the maximum of  $\alpha$  and  $\beta$ , and  $K$  is a constant, which one of the following statements is true about the output of the system ?

- (A) It will be of the form  $K\text{sinc}(\gamma t)$  where  $\gamma = \min(\alpha, \beta)$
- (B) It will be of the form  $K\text{sinc}(\gamma t)$  where  $\gamma = \max(\alpha, \beta)$
- (C) It will be of the form  $K\text{sinc}(\alpha t)$
- (D) It can not be a sinc type of signal

**MCQ 3.17**

Let  $x(t)$  be a periodic signal with time period  $T$ , Let  $y(t) = x(t - t_0) + x(t + t_0)$  for some  $t_0$ . The Fourier Series coefficients of  $y(t)$  are denoted by  $b_k$ . If  $b_k = 0$  for all odd  $k$ , then  $t_0$  can be equal to

- (A)  $T/8$
- (B)  $T/4$
- (C)  $T/2$
- (D)  $2T$

**MCQ 3.18**

$H(z)$  is a transfer function of a real system. When a signal  $x[n] = (1 + j)^n$  is the input to such a system, the output is zero. Further, the Region of convergence (ROC) of  $(1 - \frac{1}{2}z^{-1}) H(z)$  is the entire Z-plane (except  $z = 0$ ). It can then be inferred that  $H(z)$  can have a minimum of

- (A) one pole and one zero
- (B) one pole and two zeros
- (C) two poles and one zero
- (D) two poles and two zeros

**MCQ 3.19**

Given  $X(z) = \frac{z}{(z - a)^2}$  with  $|z| > a$ , the residue of  $X(z)z^{n-1}$  at  $z = a$  for  $n \geq 0$  will be

- (A)  $a^{n-1}$
- (B)  $a^n$
- (C)  $na^n$
- (D)  $na^{n-1}$

**MCQ 3.20**

Let  $x(t) = \text{rect}(t - \frac{1}{2})$  (where  $\text{rect}(x) = 1$  for  $-\frac{1}{2} \leq x \leq \frac{1}{2}$  and zero otherwise. If  $\text{sinc}(x) = \frac{\sin(\pi x)}{\pi x}$ , then the Fourier Transform of

$x(t) + x(-t)$  will be given by

- (A)  $\text{sinc}\left(\frac{\omega}{2\pi}\right)$                       (B)  $2\text{sinc}\left(\frac{\omega}{2\pi}\right)$   
 (C)  $2\text{sinc}\left(\frac{\omega}{2\pi}\right)\cos\left(\frac{\omega}{2}\right)$                       (D)  $\text{sinc}\left(\frac{\omega}{2\pi}\right)\sin\left(\frac{\omega}{2}\right)$

**MCQ 3.21**

Given a sequence  $x[n]$ , to generate the sequence  $y[n] = x[3 - 4n]$ , which one of the following procedures would be correct ?

- (A) First delay  $x(n)$  by 3 samples to generate  $z_1[n]$ , then pick every 4<sup>th</sup> sample of  $z_1[n]$  to generate  $z_2[n]$ , and then finally time reverse  $z_2[n]$  to obtain  $y[n]$ .  
 (B) First advance  $x[n]$  by 3 samples to generate  $z_1[n]$ , then pick every 4<sup>th</sup> sample of  $z_1[n]$  to generate  $z_2[n]$ , and then finally time reverse  $z_2[n]$  to obtain  $y[n]$   
 (C) First pick every fourth sample of  $x[n]$  to generate  $v_1[n]$ , time-reverse  $v_1[n]$  to obtain  $v_2[n]$ , and finally advance  $v_2[n]$  by 3 samples to obtain  $y[n]$   
 (D) First pick every fourth sample of  $x[n]$  to generate  $v_1[n]$ , time-reverse  $v_1[n]$  to obtain  $v_2[n]$ , and finally delay  $v_2[n]$  by 3 samples to obtain  $y[n]$

**YEAR 2007**

**ONE MARK**

**MCQ 3.22**

The frequency spectrum of a signal is shown in the figure. If this is ideally sampled at intervals of 1 ms, then the frequency spectrum of the sampled signal will be

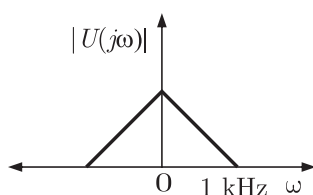



YEAR 2007

TWO MARKS

NOTES

**MCQ 3.24**

A signal  $x(t)$  is given by

$$x(t) = \begin{cases} 1, & -T/4 < t \leq 3T/4 \\ -1, & 3T/4 < t \leq 7T/4 \\ -x(t+T) \end{cases}$$

Which among the following gives the fundamental fourier term of  $x(t)$  ?

- (A)  $\frac{4}{\pi} \cos\left(\frac{\pi t}{T} - \frac{\pi}{4}\right)$                       (B)  $\frac{\pi}{4} \cos\left(\frac{\pi t}{2T} + \frac{\pi}{4}\right)$   
 (C)  $\frac{4}{\pi} \sin\left(\frac{\pi t}{T} - \frac{\pi}{4}\right)$                       (D)  $\frac{\pi}{4} \sin\left(\frac{\pi t}{2T} + \frac{\pi}{4}\right)$

**Statement for Linked Answer Question 25 and 26 :**

**MCQ 3.25**

A signal is processed by a causal filter with transfer function  $G(s)$

For a distortion free output signal wave form,  $G(s)$  must

- (A) provides zero phase shift for all frequency  
 (B) provides constant phase shift for all frequency  
 (C) provides linear phase shift that is proportional to frequency  
 (D) provides a phase shift that is inversely proportional to frequency

**MCQ 3.26**

$G(z) = \alpha z^{-1} + \beta z^{-3}$  is a low pass digital filter with a phase characteristics same as that of the above question if

- (A)  $\alpha = \beta$     (B)  $\alpha = -\beta$   
 (C)  $\alpha = \beta^{1/3}$     (D)  $\alpha = \beta^{-1/3}$

**MCQ 3.27**

Consider the discrete-time system shown in the figure where the impulse response of  $G(z)$  is  $g(0) = 0, g(1) = g(2) = 1, g(3) = g(4) = \dots = 0$

**NOTES**

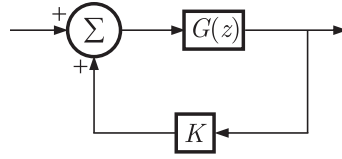

This system is stable for range of values of  $K$

- (A)  $[-1, \frac{1}{2}]$  (B)  $[-1, 1]$   
(C)  $[-\frac{1}{2}, 1]$  (D)  $[-\frac{1}{2}, 2]$

**MCQ 3.28**

If  $u(t), r(t)$  denote the unit step and unit ramp functions respectively and  $u(t) * r(t)$  their convolution, then the function  $u(t+1) * r(t-2)$  is given by

- (A)  $\frac{1}{2}(t-1)u(t-1)$  (B)  $\frac{1}{2}(t-1)u(t-2)$   
(C)  $\frac{1}{2}(t-1)^2u(t-1)$  (D) None of the above

**MCQ 3.29**

$X(z) = 1 - 3z^{-1}$ ,  $Y(z) = 1 + 2z^{-2}$  are Z transforms of two signals  $x[n], y[n]$  respectively. A linear time invariant system has the impulse response  $h[n]$  defined by these two signals as  $h[n] = x[n-1] * y[n]$  where  $*$  denotes discrete time convolution. Then the output of the system for the input  $\delta[n-1]$

- (A) has Z-transform  $z^{-1}X(z)Y(z)$   
(B) equals  $\delta[n-2] - 3\delta[n-3] + 2\delta[n-4] - 6\delta[n-5]$   
(C) has Z-transform  $1 - 3z^{-1} + 2z^{-2} - 6z^{-3}$   
(D) does not satisfy any of the above three

**YEAR 2006**

**ONE MARK**

**MCQ 3.30**

The following is true

- (A) A finite signal is always bounded  
(B) A bounded signal always possesses finite energy  
(C) A bounded signal is always zero outside the interval  $[-t_0, t_0]$  for some  $t_0$   
(D) A bounded signal is always finite

- (A)  $\sqrt{\frac{1}{6}}$  (B)  $\sqrt{\frac{1}{3}}$   
 (C)  $\frac{1}{3}$  (D)  $\sqrt{\frac{2}{3}}$

**MCQ 3.38**

The Laplace transform of a function  $f(t)$  is  $F(s) = \frac{5s^2 + 23s + 6}{s(s^2 + 2s + 2)}$  as  $t \rightarrow \infty$ ,  $f(t)$  approaches

- (A) 3 (B) 5  
 (C)  $\frac{17}{2}$  (D)  $\infty$

**MCQ 3.39**

The Fourier series for the function  $f(x) = \sin^2 x$  is

- (A)  $\sin x + \sin 2x$  (B)  $1 - \cos 2x$   
 (C)  $\sin 2x + \cos 2x$  (D)  $0.5 - 0.5 \cos 2x$

**MCQ 3.40**

If  $u(t)$  is the unit step and  $\delta(t)$  is the unit impulse function, the inverse  $z$ -transform of  $F(z) = \frac{1}{z+1}$  for  $k > 0$  is

- (A)  $(-1)^k \delta(k)$  (B)  $\delta(k) - (-1)^k$   
 (C)  $(-1)^k u(k)$  (D)  $u(k) - (-1)^k$

**YEAR 2004**

**TWO MARKS**

**MCQ 3.41**

The rms value of the periodic waveform given in figure is

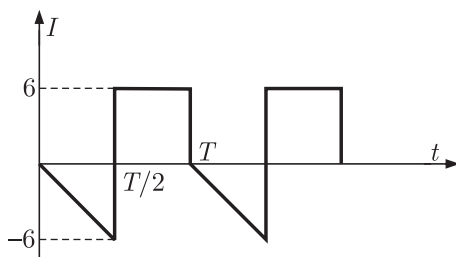

- (A)  $2\sqrt{6}$  A (B)  $6\sqrt{2}$  A  
 (C)  $\sqrt{4/3}$  A (D) 1.5 A



**NOTES**

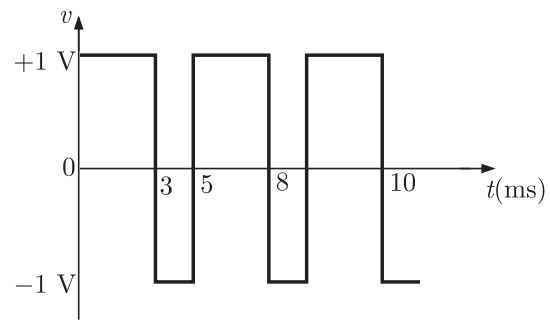

**MCQ 3.48**

The DC component of  $v$  is

- (A) 0.4 (B) 0.2  
(C) 0.8 (D) 0.1

**MCQ 3.49**

The amplitude of fundamental component of  $v$  is

- (A) 1.20 V (B) 2.40 V  
(C) 2 V (D) 1 V

\*\*\*\*\*

**NOTES**

**Causality :**

$y(t)$  depends on  $x(5t)$ ,  $t > 0$  system is non-causal.

For example  $t = 2$

$y(2)$  depends on  $x(10)$  (future value of input)

**Linearity :**

Output is integration of input which is a linear function, so system is linear.

Hence (B) is correct option.

**SOL 3.4**

Fourier series of given function

$$x(t) = A_0 + \sum_{n=1}^{\infty} a_n \cos n\omega_0 t + b_n \sin n\omega_0 t$$

$$\because x(t) = -x(t) \text{ odd function}$$

So,  $A_0 = 0$

$$a_n = 0$$

$$\begin{aligned} b_n &= \frac{2}{T} \int_0^T x(t) \sin n\omega_0 t dt \\ &= \frac{2}{T} \left[ \int_0^{T/2} (1) \sin n\omega_0 t dt + \int_{T/2}^T (-1) \sin n\omega_0 t dt \right] \\ &= \frac{2}{T} \left[ \left( \frac{\cos n\omega_0 t}{-n\omega_0} \right)_0^{T/2} - \left( \frac{\cos n\omega_0 t}{-n\omega_0} \right)_{T/2}^T \right] \\ &= \frac{2}{n\omega_0 T} [(1 - \cos n\pi) + (\cos 2n\pi - \cos n\pi)] \\ &= \frac{2}{n\pi} [1 - (-1)^n] \\ b_n &= \begin{cases} \frac{4}{n\pi}, & n \text{ odd} \\ 0, & n \text{ even} \end{cases} \end{aligned}$$

So only odd harmonic will be present in  $x(t)$

For second harmonic component ( $n = 2$ ) amplitude is zero.

Hence option (A) is correct.

**SOL 3.5**

By parseval's theorem

$$\frac{1}{2\pi} \int_{-\infty}^{\infty} |X(\omega)|^2 d\omega = \int_{-\infty}^{\infty} x^2(t) dt$$

$$\int_{-\infty}^{\infty} |X(\omega)|^2 d\omega = 2\pi \times 2 = 4\pi$$

Hence option (D) is correct.

**SOL 3.6**

Given sequences

$$x[n] = \{1, -1\}, \quad 0 \leq n \leq 1$$

$$y[n] = \{1, 0, 0, 0, -1\}, \quad 0 \leq n \leq 4$$

If impulse response is  $h[n]$  then

$$y[n] = h[n] * x[n]$$

Length of convolution ( $y[n]$ ) is 0 to 4,  $x[n]$  is of length 0 to 1 so length of  $h[n]$  will be 0 to 3.

Let  $h[n] = \{a, b, c, d\}$

Convolution

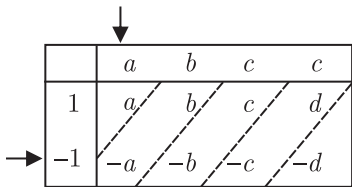

$$y[n] = \{a, -a + b, -b + c, -c + d, -d\}$$

By comparing

$$\begin{aligned} a &= 1 \\ -a + b &= 0 \Rightarrow b = a = 1 \\ -b + c &= 0 \Rightarrow c = b = 1 \\ -c + d &= 0 \Rightarrow d = c = 1 \end{aligned}$$

So,  $h[n] = \{1, 1, 1, 1\}$

Hence option (C) is correct.

**SOL 3.7**

We can observe that if we scale  $f(t)$  by a factor of  $\frac{1}{2}$  and then shift, we will get  $g(t)$ .

First scale  $f(t)$  by a factor of  $\frac{1}{2}$

$$g_1(t) = f(t/2)$$

$$Y'(s) = e^{-2s\tau} X(s) H(s)$$

$$Y'(s) = e^{-2s\tau} Y(s)$$

Or  $y'(t) = y(t - 2\tau)$

Hence (D) is correct option.

**SOL 3.10**

Let three LTI systems having response  $H_1(z)$ ,  $H_2(z)$  and  $H_3(z)$  are Cascaded as showing below

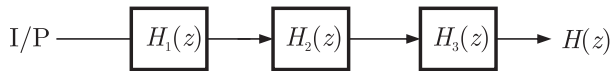

Assume  $H_1(z) = z^2 + z^1 + 1$  (non-causal)

$$H_2(z) = z^3 + z^2 + 1 \text{ (non-causal)}$$

Overall response of the system

$$H(z) = H_1(z) H_2(z) H_3(z)$$

$$H(z) = (z^2 + z^1 + 1)(z^3 + z^2 + 1) H_3(z)$$

To make  $H(z)$  causal we have to take  $H_3(z)$  also causal.

Let  $H_3(z) = z^{-6} + z^4 + 1$

$$H(z) = (z^2 + z^1 + 1)(z^3 + z^2 + 1)(z^{-6} + z^4 + 1)$$

$$H(z) \rightarrow \text{causal}$$

Similarly to make  $H(z)$  unstable atleast one of the system should be unstable.

Hence (B) is correct option.

**SOL 3.11**

Given signal

$$x(t) = \sum_{k=-\infty}^{\infty} a_k e^{j2\pi kt/T}$$

Let  $\omega_0$  is the fundamental frequency of signal  $x(t)$

$$x(t) = \sum_{k=-\infty}^{\infty} a_k e^{jk\omega_0 t} \quad \because \frac{2\pi}{T} = \omega_0$$

$$\begin{aligned} x(t) &= a_{-2} e^{-j2\omega_0 t} + a_{-1} e^{-j\omega_0 t} + a_0 + a_1 e^{j\omega_0 t} + a_2 e^{j2\omega_0 t} \\ &= (2 - j) e^{-2j\omega_0 t} + (0.5 + 0.2j) e^{-j\omega_0 t} + 2j + \\ &\quad + (0.5 - 0.2) e^{j\omega_0 t} + (2 + j) e^{j2\omega_0 t} \\ &= 2[e^{-j2\omega_0 t} + e^{j2\omega_0 t}] + j[e^{j2\omega_0 t} - e^{-j2\omega_0 t}] + \end{aligned}$$



**NOTES**

$$\begin{aligned}
 & 0.5[e^{j\omega_0 t} + e^{-j\omega_0 t}] - 0.2j[e^{+j\omega_0 t} - e^{-j\omega_0 t}] + 2j \\
 &= 2(2 \cos 2\omega_0 t) + j(2j \sin 2\omega_0 t) + 0.5(2 \cos \omega_0 t) - \\
 & \quad 0.2j(2j \sin \omega_0 t) + 2j \\
 &= [4 \cos 2\omega_0 t - 2 \sin 2\omega_0 t + \cos \omega_0 t + \\
 & \quad 0.4 \sin \omega_0 t] + 2j
 \end{aligned}$$

$$\text{Im}[x(t)] = 2 \text{ (constant)}$$

Hence (C) is correct option.

**SOL 3.12**

Z-transform of  $x[n]$  is

$$X(z) = 4z^{-3} + 3z^{-1} + 2 - 6z^2 + 2z^3$$

Transfer function of the system

$$H(z) = 3z^{-1} - 2$$

Output

$$\begin{aligned}
 Y(z) &= H(z)X(z) \\
 Y(z) &= (3z^{-1} - 2)(4z^{-3} + 3z^{-1} + 2 - 6z^2 + 2z^3) \\
 &= 12z^{-4} + 9z^{-2} + 6z^{-1} - 18z + 6z^2 - 8z^{-3} - 6z^{-1} \\
 & \quad - 4 + 12z^2 - 4z^3 \\
 &= 12z^{-4} - 8z^{-3} + 9z^{-2} - 4 - 18z + 18z^2 - 4z^3
 \end{aligned}$$

Or sequence  $y[n]$  is

$$\begin{aligned}
 y[n] &= 12\delta[n-4] - 8\delta[n-3] + 9\delta[n-2] - 4\delta[n] - \\
 & \quad 18\delta[n+1] + 18\delta[n+2] - 4\delta[n+3] \\
 y[n] &\neq 0, n < 0
 \end{aligned}$$

So  $y[n]$  is non-causal with finite support.

Hence (A) is correct option.

**SOL 3.13**

Since the given system is LTI, So principal of Superposition holds due to linearity.

For causal system  $h(t) = 0, t < 0$

Both statement are correct.

Hence (D) is correct option.

**SOL 3.14**

For an LTI system output is a constant multiplicative of input with same frequency.

**NOTES**

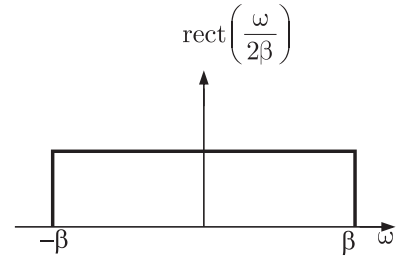
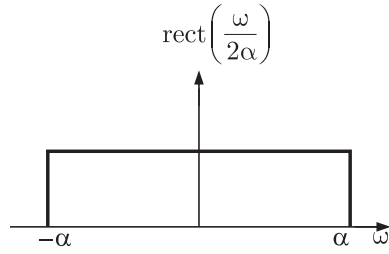

So,  $Y(j\omega) = K \text{rect}\left(\frac{\omega}{2\gamma}\right)$

Where  $\gamma = \min(\alpha, \beta)$

And  $y(t) = K \text{sinc}(\gamma t)$

Hence (A) is correct option.

**SOL 3.17**

Let  $a_k$  is the Fourier series coefficient of signal  $x(t)$

Given  $y(t) = x(t - t_0) + x(t + t_0)$

Fourier series coefficient of  $y(t)$

$$b_k = e^{-jk\omega t_0} a_k + e^{jk\omega t_0} a_k$$

$$b_k = 2a_k \cos k\omega t_0$$

$$b_k = 0 \text{ (for all odd } k\text{)}$$

$$k\omega t_0 = \frac{\pi}{2}, k \rightarrow \text{odd}$$

$$k \frac{2\pi}{T} t_0 = \frac{\pi}{2}$$

For  $k = 1, t_0 = \frac{T}{4}$

Hence (B) is correct option.

**SOL 3.18**

**SOL 3.19**

Given that  $X(z) = \frac{z}{(z - a)^2}, |z| > a$

Residue of  $X(z)z^{n-1}$  at  $z = a$  is

$$\begin{aligned} &= \frac{d}{dz} (z - a)^2 X(z) z^{n-1} \Big|_{z=a} \\ &= \frac{d}{dz} (z - a)^2 \frac{z}{(z - a)^2} z^{n-1} \Big|_{z=a} \\ &= \frac{d}{dz} z^n \Big|_{z=a} \end{aligned}$$

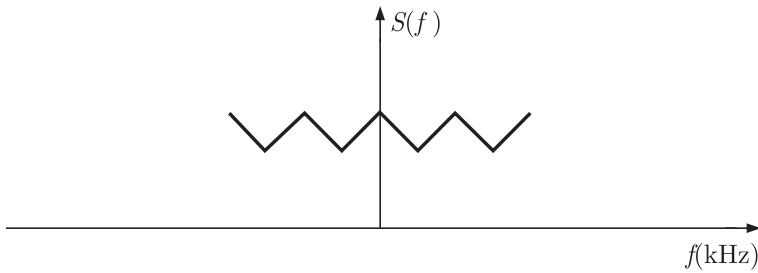

**SOL 3.23**

For an LTI system input and output have identical wave shape (i.e. frequency of input-output is same) within a multiplicative constant (i.e. Amplitude response is constant)

So  $F$  must be a sine or cosine wave with  $\omega_1 = \omega_2$

Hence (D) is correct option.

**SOL 3.24**

Given signal has the following wave-form

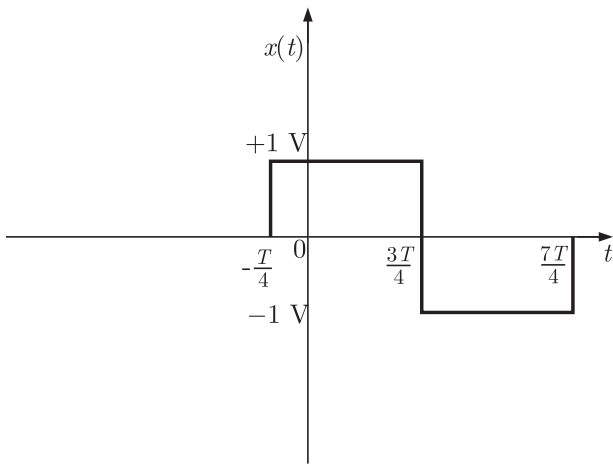

Function  $x(t)$  is periodic with period  $2T$  and given that

$$x(t) = -x(t + T) \text{ (Half-wave symmetric)}$$

So we can obtain the fourier series representation of given function.

Hence (C) is correct option.

**SOL 3.25**

Output is said to be distortion less if the input and output have

**NOTES**

identical wave shapes within a multiplicative constant. A delayed output that retains input waveform is also considered distortion less. Thus for distortion less output, input-output relationship is given as

$$y(t) = Kg(t - t_d)$$

Taking Fourier transform.

$$Y(\omega) = KG(\omega) e^{-j\omega t_d}$$

$$Y(\omega) = G(\omega) H(\omega)$$

$H(\omega) \Rightarrow$  transfer function of the system

So, 
$$H(\omega) = Ke^{-j\omega t_d}$$

Amplitude response  $|H(\omega)| = K$

Phase response  $\theta_n(\omega) = -\omega t_d$

For distortion less output, phase response should be proportional to frequency.

Hence (C) is correct option.

**SOL 3.26**

$$G(z) \Big|_{z=e^{j\omega}} = \alpha e^{-j\omega} + \beta e^{-3j\omega}$$

for linear phase characteristic  $\alpha = \beta$ .

Hence (A) is correct option.

**SOL 3.27**

System response is given as

$$H(z) = \frac{G(z)}{1 - KG(z)}$$

$$g[n] = \delta[n - 1] + \delta[n - 2]$$

$$G(z) = z^{-1} + z^{-2}$$

So 
$$H(z) = \frac{(z^{-1} + z^{-2})}{1 - K(z^{-1} + z^{-2})}$$

$$= \frac{z + 1}{z^2 - Kz - K}$$

For system to be stable poles should lie inside unit circle.

$$|z| \leq 1$$

$$z = \frac{K \pm \sqrt{K^2 + 4K}}{2} \leq 1$$

$$K \pm \sqrt{K^2 + 4K} \leq 2$$

$$\begin{aligned}\sqrt{K^2 + 4K} &\leq 2 - K \\ K^2 + 4K &\leq 4 - 4K + K^2 \\ 8K &\leq 4 \\ K &\leq 1/2\end{aligned}$$

Hence (A) is correct option.

**SOL 3.28**

Given Convolution is,

$$h(t) = u(t+1) * r(t-2)$$

Taking Laplace transform on both sides,

$$H(s) = \mathcal{L}[h(t)] = \mathcal{L}[u(t+1)] * \mathcal{L}[r(t-2)]$$

We know that,  $\mathcal{L}[u(t)] = 1/s$

$$\mathcal{L}[u(t+1)] = e^s \left( \frac{1}{s^2} \right) \quad (\text{Time-shifting property})$$

and

$$\begin{aligned}\mathcal{L}[r(t)] &= 1/s^2 \\ \mathcal{L}[r(t-2)] &= e^{-2s} \left( \frac{1}{s^2} \right) \quad (\text{Time-shifting property})\end{aligned}$$

So

$$\begin{aligned}H(s) &= \left[ e^s \left( \frac{1}{s} \right) \right] \left[ e^{-2s} \left( \frac{1}{s^2} \right) \right] \\ H(s) &= e^{-s} \left( \frac{1}{s^3} \right)\end{aligned}$$

Taking inverse Laplace transform

$$h(t) = \frac{1}{2}(t-1)^2 u(t-1)$$

Hence (C) is correct option.

**SOL 3.29**

Impulse response of given LTI system.

$$h[n] = x[n-1] * y[n]$$

Taking  $z$ -transform on both sides.

$$\begin{aligned}H(z) &= z^{-1}X(z)Y(z) \\ \therefore x[n-1] &\xrightarrow{\mathcal{Z}} z^{-1}x(z)\end{aligned}$$

We have  $X(z) = 1 - 3z^{-1}$  and  $Y(z) = 1 + 2z^{-2}$

So

$$H(z) = z^{-1}(1 - 3z^{-1})(1 + 2z^{-2})$$

Output of the system for input  $u[n] = \delta[n-1]$  is,

$$\begin{aligned}y(z) &= H(z)U(z) \\ U[n] &\xrightarrow{\mathcal{Z}} U(z) = z^{-1}\end{aligned}$$

**NOTES**

So

$$\begin{aligned} Y(z) &= z^{-1}(1 - 3z^{-1})(1 + 2z^{-2})z^{-1} \\ &= z^{-2}(1 - 3z^{-1} + 2z^{-2} - 6z^{-3}) \\ &= z^{-2} - 3z^{-3} + 2z^{-4} - 6z^{-5} \end{aligned}$$

Taking inverse z-transform on both sides we have output.

$$y[n] = \delta[n - 2] - 3\delta[n - 3] + 2\delta[n - 4] - 6\delta[n - 5]$$

Hence (C) is correct option.

**SOL 3.30**

A bounded signal always possesses some finite energy.

$$E = \int_{-t_0}^{t_0} |g(t)|^2 dt < \infty$$

Hence (B) is correct option.

**SOL 3.31**

Trigonometric Fourier series is given as

$$x(t) = A_0 + \sum_{n=1}^{\infty} a_n \cos n\omega_0 t + b_n \sin n\omega_0 t$$

Since there are no sine terms, so  $b_n = 0$

$$\begin{aligned} b_n &= \frac{2}{T_0} \int_0^{T_0} x(t) \sin n\omega_0 t dt \\ &= \frac{2}{T_0} \left[ \int_0^{T_0/2} x(\tau) \sin n\omega_0 \tau d\tau + \int_{T_0/2}^T x(t) \sin n\omega_0 t dt \right] \end{aligned}$$

Where  $\tau = T - t \Rightarrow d\tau = -dt$

$$\begin{aligned} &= \frac{2}{T_0} \left[ \int_{T_0}^{T_0/2} x(T - t) \sin n\omega_0 (T - t) (-dt) \right. \\ &\quad \left. + \int_{T_0/2}^T x(t) \sin n\omega_0 t dt \right] \\ &= \frac{2}{T_0} \left[ \int_{T_0/2}^{T_0} x(T - t) \sin n\left(\frac{2\pi}{T} T - t\right) dt + \right. \\ &\quad \left. + \int_{T_0/2}^T x(t) \sin n\omega_0 t dt \right] \\ &= \frac{2}{T_0} \left[ \int_{T_0/2}^{T_0} x(T - t) \sin (2n\pi - n\omega_0 t) dt \right. \\ &\quad \left. + \int_{T_0/2}^{T_0} x(t) \sin n\omega_0 t dt \right] \\ &= \frac{2}{T_0} \left[ - \int_{T_0/2}^{T_0} x(T - t) \sin (n\omega_0 t) dt + \right. \end{aligned}$$

**NOTES**

Since length of convolution ( $y[n]$ ) is  $-1$  to  $2$ ,  $x[n]$  is of length  $-1$  to  $0$  so length of  $h[n]$  is  $0$  to  $2$ .

Let  $h[n] = \{a, b, c\}$

Convolution

	↓			
		$a$	$b$	$c$
	-1	- $a$	- $b$	- $c$
→	2	2 $a$	2 $b$	2 $c$

$$y[n] = \{-a, 2a - b, 2b - c, 2c\}$$

$$y[n] = \{-1, 3, -1, -2\}$$

So,

$$a = 1$$

$$2a - b = 3 \Rightarrow b = -1$$

$$2a - c = -1 \Rightarrow c = -1$$

Impulse response  $h[n] = \{1, -1, -1\}$

Hence (A) is correct option.

**SOL 3.34**

Option ( ) is correct

**SOL 3.35**

Output  $y(t) = e^{-|x(t)|}$

If  $x(t)$  is unbounded,  $|x(t)| \rightarrow \infty$

$$y(t) = e^{-|x(t)|} \rightarrow 0 \text{ (bounded)}$$

So  $y(t)$  is bounded even when  $x(t)$  is not bounded.

Hence (D) is correct option.

**SOL 3.36**

Given  $y(t) = \int_{-\infty}^t x(t') dt'$

Laplace transform of  $y(t)$

$$Y(s) = \frac{X(s)}{s}, \text{ has a singularity at } s = 0$$

For a causal bounded input,  $y(t) = \int_{-\infty}^t x(t') dt'$  is always bounded.  
Hence (B) is correct option

**SOL 3.37**

RMS value is given by

$$V_{rms} = \sqrt{\frac{1}{T} \int_0^T V^2(t) dt}$$

Where

$$V(t) = \begin{cases} \left(\frac{2}{T}\right)t, & 0 \leq t \leq \frac{T}{2} \\ 0, & \frac{T}{2} < t \leq T \end{cases}$$

$$\begin{aligned} \text{So } \frac{1}{T} \int_0^T V^2(t) dt &= \frac{1}{T} \left[ \int_0^{T/2} \left(\frac{2t}{T}\right)^2 dt + \int_{T/2}^T (0) dt \right] \\ &= \frac{1}{T} \cdot \frac{4}{T^2} \int_0^{T/2} t^2 dt \\ &= \frac{4}{T^3} \left[ \frac{t^3}{3} \right]_0^{T/2} \\ &= \frac{4}{T^3} \times \frac{T^3}{24} \\ &= \frac{1}{6} \\ V_{rms} &= \sqrt{\frac{1}{6}} \text{ V} \end{aligned}$$

Hence (A) is correct option

**SOL 3.38**

By final value theorem

$$\begin{aligned} \lim_{t \rightarrow \infty} f(t) &= \lim_{s \rightarrow 0} s F(s) \\ &= \lim_{s \rightarrow 0} s \frac{(5s^2 + 23s + 6)}{s(s^2 + 2s + 2)} \\ &= \frac{6}{2} = 3 \end{aligned}$$

Hence (A) is correct option

**SOL 3.39**

$$\begin{aligned} f(x) &= \sin^2 x \\ &= \frac{1 - \cos 2x}{2} \end{aligned}$$



**SOL 3.42**

Total current in wire

$$I = 10 + 20 \sin \omega t$$

$$I_{rms} = \sqrt{(10)^2 + \frac{(20)^2}{2}} = 17.32 \text{ A}$$

Hence (B) is correct option

**SOL 3.43**

Fourier series representation is given as

$$f(t) = A_0 + \sum_{n=1}^{\infty} a_n \cos n\omega_0 t + b_n \sin n\omega_0 t$$

From the wave form we can write fundamental period  $T = 2$  sec

$$f(t) = \begin{cases} \left(\frac{4}{T}\right)t, & -\frac{T}{2} \leq t \leq 0 \\ -\left(\frac{4}{T}\right)t, & 0 \leq t \leq \frac{T}{2} \end{cases}$$

$f(t) = f(-t)$ ,  $f(t)$  is an even function

So,

$$b_n = 0$$

$$A_0 = \frac{1}{T} \int_T f(t) dt$$

$$= \frac{1}{T} \left[ \int_{-T/2}^0 \left(\frac{4}{T}\right)t dt + \int_0^{T/2} \left(-\frac{4}{T}\right)t dt \right]$$

$$= \frac{1}{T} \left( \frac{4}{T} \left[ \frac{t^2}{2} \right]_{-T/2}^0 - \frac{4}{T} \left[ \frac{t^2}{2} \right]_0^{T/2} \right)$$

$$= \frac{1}{T} \left[ \frac{4}{T} \left( \frac{T^2}{8} \right) - \frac{4}{T} \left( \frac{T^2}{8} \right) \right] = 0$$

$$a_n = \frac{2}{T} \int_T f(t) \cos n\omega_0 t dt$$

$$= \frac{2}{T} \left[ \int_{-T/2}^0 \left(\frac{4}{T}\right)t \cos n\omega_0 t + \int_0^{T/2} \left(-\frac{4}{T}\right)t \cos n\omega_0 t dt \right]$$

By solving the integration

$$a_n = \begin{cases} \frac{8}{n^2 \pi^2}, & n \text{ is odd} \\ 0, & n \text{ is even} \end{cases}$$

So,

$$f(t) = \frac{8}{\pi^2} \left[ \cos \pi t + \frac{1}{9} \cos (3\pi t) + \frac{1}{25} \cos (5\pi t) + \dots \right]$$

Hence (C) is correct option

**NOTES**

**SOL 3.44**

Response for any input  $u(t)$  is given as

$$y(t) = u(t) * h(t) \quad h(t) \rightarrow \text{impulse response}$$

$$y(t) = \int_{-\infty}^{\infty} u(\tau) h(t - \tau) d\tau$$

Impulse response  $h(t)$  and step response  $s(t)$  of a system is related as

$$h(t) = \frac{d}{dt}[s(t)]$$

So

$$y(t) = \int_{-\infty}^{\infty} u(\tau) \frac{d}{dt} s[t - \tau] d\tau$$

$$= \frac{d}{dt} \int_{-\infty}^{\infty} u(\tau) s(t - \tau) d\tau$$

Hence (A) is correct option

**SOL 3.45**

Final value theorem states that

$$\lim_{t \rightarrow \infty} y(t) = \lim_{s \rightarrow \infty} s Y(s)$$

Hence (B) is correct option.

**SOL 3.46**

$$V_{rms} = \sqrt{\frac{1}{T_0} \int_{T_0} V^2(t) dt}$$

here  $T_0 = \pi$

$$\frac{1}{T_0} \int_{T_0} V^2(t) dt = \frac{1}{\pi} \left[ \int_0^{\pi/3} (100)^2 dt + \int_{\pi/3}^{2\pi/3} (-100)^2 dt + \int_{2\pi/3}^{\pi} (100)^2 dt \right]$$

$$= \frac{1}{\pi} \left[ 10^4 \left( \frac{\pi}{3} \right) + 10^4 \left( \frac{\pi}{3} \right) + 10^4 \left( \frac{\pi}{3} \right) \right] = 10^4 \text{ V}$$

$$V_{rms} = \sqrt{10^4} = 100 \text{ V}$$

Hence (D) is correct option.

**SOL 3.47**

Let  $h(t)$  is the impulse response of system

$$y(t) = u(t) * h(t)$$

$$y(t) = \int_0^t u(\tau) h(t - \tau) d\tau$$

$$= \int_0^t (2 + t - \tau) e^{-3(t-\tau)} u(\tau) d\tau$$

**NOTES**

$$= \frac{2}{n\pi} \sin\left(\frac{6\pi n}{5}\right)$$

Coefficient,  $b_n = \frac{2}{T} \int_T v(t) \sin n\omega_0 t dt$

$$= \frac{2}{5} \left[ \int_0^3 (1) \sin n\omega t dt + \int_3^5 (-1) \sin n\omega t dt \right]$$

$$= \frac{2}{5} \left( \left[ -\frac{\cos n\omega t}{n\omega} \right]_0^3 - \left[ -\frac{\cos n\omega t}{n\omega} \right]_3^5 \right)$$

put  $\omega = \frac{2\pi}{T} = \frac{2\pi}{5}$

$$b_n = \frac{1}{n\pi} [-\cos 3n\omega + 1 + \cos 5n\omega - \cos 3n\omega]$$

$$= \frac{1}{n\pi} [-2\cos 3n\omega + 1 + \cos 5n\omega]$$

$$= \frac{1}{n\pi} \left[ -2\cos\left(3n\frac{2\pi}{5}\right) + 1 + \cos\left(5n\frac{2\pi}{5}\right) \right]$$

$$= \frac{1}{n\pi} \left[ -2\cos\left(\frac{6\pi n}{5}\right) + 1 + 1 \right]$$

$$= \frac{2}{n\pi} \left[ 1 - \cos\left(\frac{6\pi n}{5}\right) \right]$$

Amplitude of fundamental component of  $v$  is

$$v_f = \sqrt{a_1^2 + b_1^2}$$

$$a_1 = \frac{2}{\pi} \sin\left(\frac{6\pi}{5}\right), b_1 = \frac{2}{\pi} \left(1 - \cos\frac{6\pi}{5}\right)$$

$$v_f = \frac{2}{\pi} \sqrt{\sin^2 \frac{6\pi}{5} + \left(1 - \cos\frac{6\pi}{5}\right)^2}$$

$$= 1.20 \text{ Volt}$$

Hence (A) is correct option.

\*\*\*\*\*

# 4

---

## CHAPTER

---

# ELECTRICAL MACHINES

---

YEAR 2010

ONE MARK

### MCQ 4.1

A Single-phase transformer has a turns ratio 1:2, and is connected to a purely resistive load as shown in the figure. The magnetizing current drawn is 1 A, and the secondary current is 1 A. If core losses and leakage reactances are neglected, the primary current is

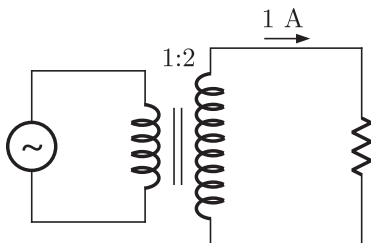

- (A) 1.41 A                      (B) 2 A  
(C) 2.24 A                      (D) 3 A

### MCQ 4.2

A balanced three-phase voltage is applied to a star-connected induction motor, the phase to neutral voltage being  $V$ . The stator resistance, rotor resistance referred to the stator, stator leakage reactance, rotor leakage reactance referred to the stator, and the magnetizing reactance are denoted by  $r_s$ ,  $r_r$ ,  $X_s$ ,  $X_r$  and  $X_m$ , respectively. The magnitude of the starting current of the motor is given by

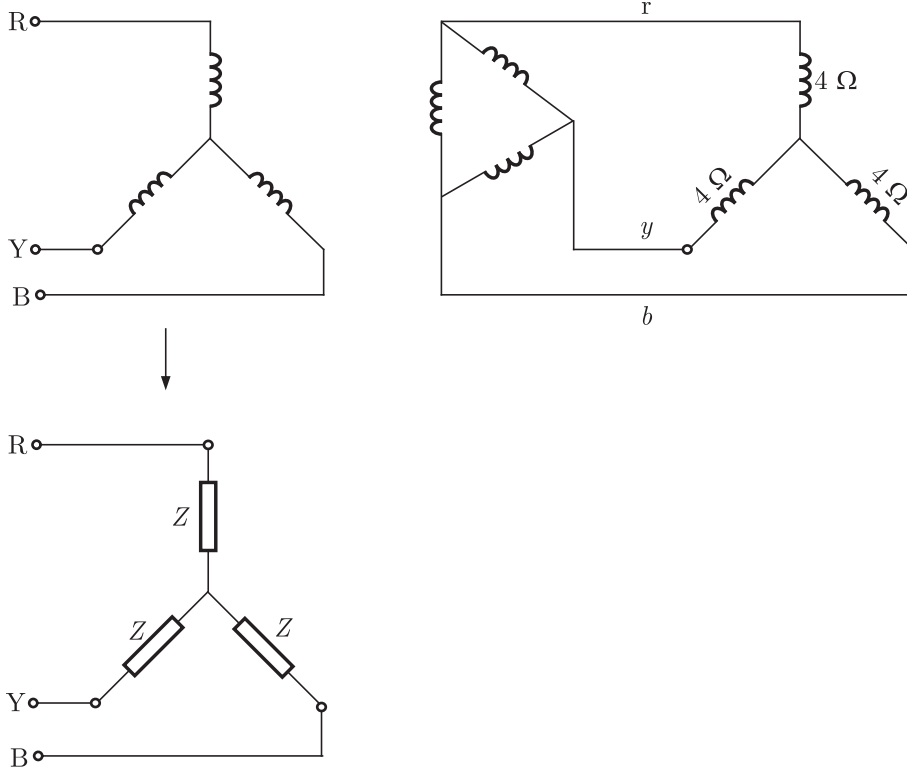

- (A)  $(3 + j0) \Omega$                       (B)  $(0.866 - j0.5) \Omega$   
 (C)  $(0.866 + j0.5) \Omega$               (D)  $(1 + j0) \Omega$

**Common Data for Questions 5 and 6**

A separately excited DC motor runs at 1500 rpm under no-load with 200 V applied to the armature. The field voltage is maintained at its rated value. The speed of the motor, when it delivers a torque of 5 Nm, is 1400 rpm as shown in figure. The rotational losses and armature reaction are neglected.

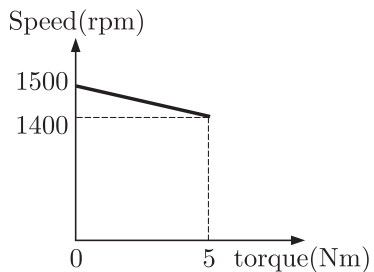

**NOTES**

**MCQ 4.5**

The armature resistance of the motor is

- (A)  $2 \Omega$  (B)  $3.4 \Omega$   
(C)  $4.4 \Omega$  (D)  $7.7 \Omega$

**MCQ 4.6**

For the motor to deliver a torque of 2.5 Nm at 1400 rpm, the armature voltage to be applied is

- (A) 125.5 V (B) 193.3 V  
(C) 200 V (D) 241.7 V

**YEAR 2009**

**ONE MARK**

**MCQ 4.7**

A field excitation of 20 A in a certain alternator results in an armature current of 400 A in short circuit and a terminal voltage of 2000 V on open circuit. The magnitude of the internal voltage drop within the machine at a load current of 200 A is

- (A) 1 V (B) 10 V  
(C) 100 V (D) 1000 V

**MCQ 4.8**

The single phase, 50 Hz iron core transformer in the circuit has both the vertical arms of cross sectional area  $20 \text{ cm}^2$  and both the horizontal arms of cross sectional area  $10 \text{ cm}^2$ . If the two windings shown were wound instead on opposite horizontal arms, the mutual inductance will

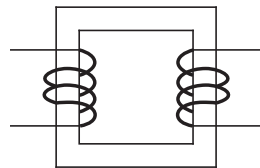

- (A) double (B) remain same  
(C) be halved (D) become one quarter

**NOTES**

(C) does not rotate

(D) rotates momentarily and comes to a halt

**Common Data for Questions 11 and 12 :**

The circuit diagram shows a two-winding, lossless transformer with no leakage flux, excited from a current source,  $i(t)$ , whose waveform is also shown. The transformer has a magnetizing inductance of  $400/\pi$  mH.

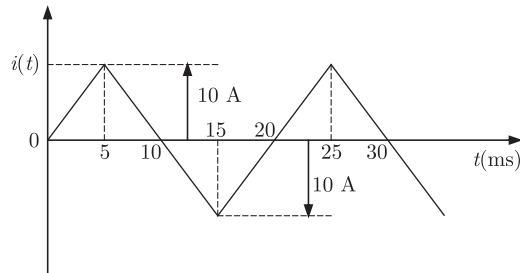
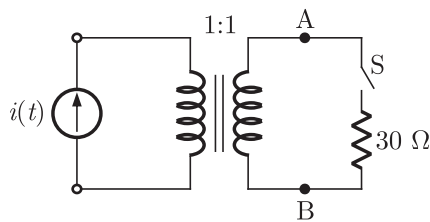

**MCQ 4.11**

The peak voltage across A and B, with S open is

(A)  $\frac{400}{\pi}$  V

(B) 800 V

(C)  $\frac{4000}{\pi}$  V

(D)  $\frac{800}{\pi}$  V

**MCQ 4.12**

If the wave form of  $i(t)$  is changed to  $i(t) = 10 \sin(100\pi t)$  A, the peak voltage across A and B with S closed is

(A) 400 V

(B) 240 V

(C) 320 V

(D) 160 V

**MCQ 4.13**

Figure shows the extended view of a 2-pole dc machine with 10 armature conductors. Normal brush positions are shown by A and B, placed at the interpolar axis. If the brushes are now shifted, in the direction of rotation, to A' and B' as shown, the voltage waveform  $V_{A'B'}$  will resemble

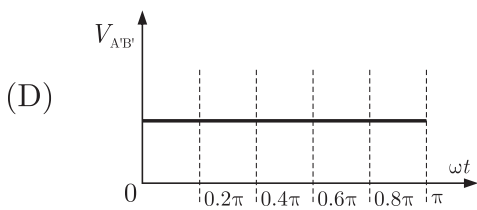
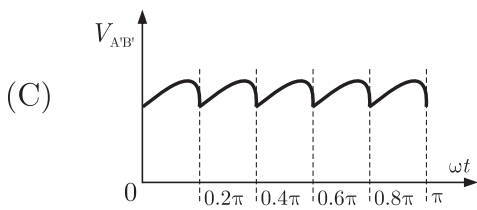
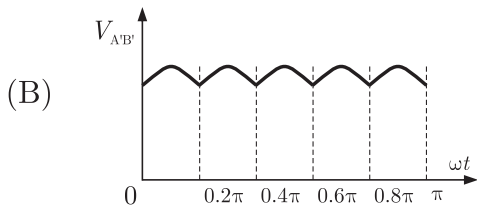
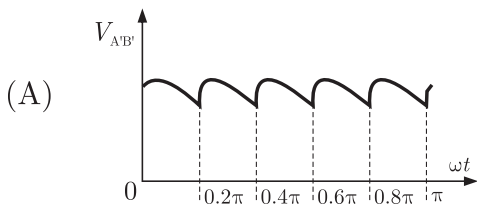
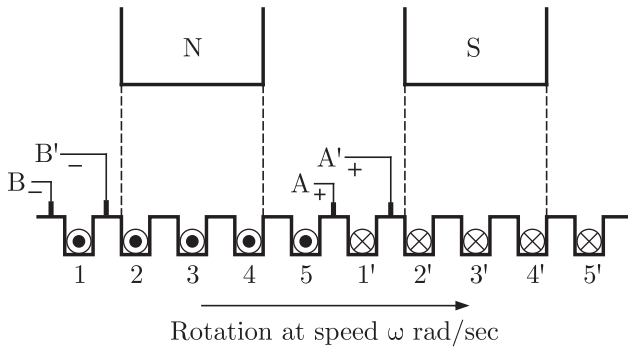

**NOTES**



The figure above shows coils-1 and 2, with dot markings as shown, having 4000 and 6000 turns respectively. Both the coils have a rated current of 25 A. Coil-1 is excited with single phase, 400 V, 50 Hz supply.

**MCQ 4.16**

The coils are to be connected to obtain a single-phase,  $\frac{400}{1000}$  V, auto-transformer to drive a load of 10 kVA. Which of the options given should be exercised to realize the required auto-transformer ?

- (A) Connect A and D; Common B
- (B) Connect B and D; Common C
- (C) Connect A and C; Common B
- (D) Connect A and C; Common D

**MCQ 4.17**

In the autotransformer obtained in Question 16, the current in each coil is

- (A) Coil-1 is 25 A and Coil-2 is 10 A
- (B) Coil-1 is 10 A and Coil-2 is 25 A
- (C) Coil-1 is 10 A and Coil-2 is 15 A
- (D) Coil-1 is 15 A and Coil-2 is 10 A

**YEAR 2008**

**ONE MARK**

**MCQ 4.18**

Distributed winding and short chording employed in AC machines will result in

- (A) increase in emf and reduction in harmonics
- (B) reduction in emf and increase in harmonics
- (C) increase in both emf and harmonics
- (D) reduction in both emf and harmonics

**MCQ 4.19**

Three single-phase transformer are connected to form a 3-phase transformer bank. The transformers are connected in the following manner :



(C) 266.6 V, 33.3 Hz

(D) 323.3 V, 40.3 Hz

**Common Data for Questions 26 and 27.**

A 3-phase, 440 V, 50 Hz, 4-pole slip ring induction motor is fed from the rotor side through an auto-transformer and the stator is connected to a variable resistance as shown in the figure.

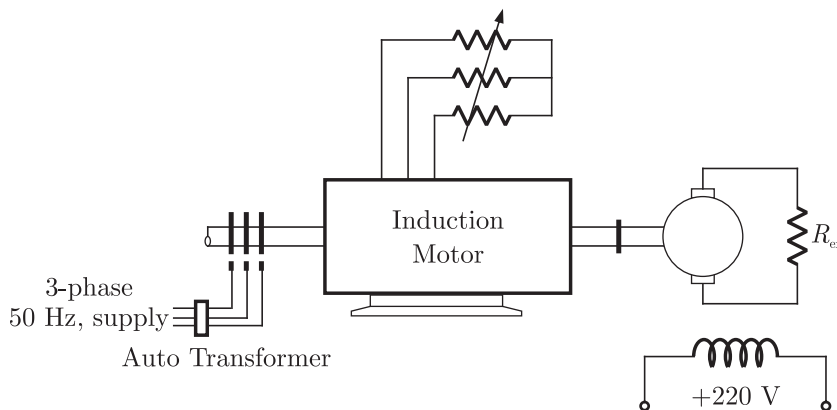

The motor is coupled to a 220 V, separately excited d.c generator feeding power to fixed resistance of  $10 \Omega$ . Two-wattmeter method is used to measure the input power to induction motor. The variable resistance is adjusted such the motor runs at 1410 rpm and the following readings were recorded  $W_1 = 1800 \text{ W}$ ,  $W_2 = -200 \text{ W}$ .

**MCQ 4.26**

The speed of rotation of stator magnetic field with respect to rotor structure will be

- (A) 90 rpm in the direction of rotation
- (B) 90 rpm in the opposite direction of rotation
- (C) 1500 rpm in the direction of rotation
- (D) 1500 rpm in the opposite direction of rotation

**MCQ 4.27**

Neglecting all losses of both the machines, the dc generator power output and the current through resistance ( $R_{ex}$ ) will respectively be

- (A) 96 W, 3.10 A
- (B) 120 W, 3.46 A
- (C) 1504 W, 12.26 A
- (D) 1880 W, 13.71 A

YEAR 2007

ONE MARK

NOTES

**MCQ 4.32**

In a transformer, zero voltage regulation at full load is

- (A) not possible
- (B) possible at unity power factor load
- (C) possible at leading power factor load
- (D) possible at lagging power factor load

**MCQ 4.33**

The dc motor, which can provide zero speed regulation at full load without any controller is

- (A) series
- (B) shunt
- (C) cumulative compound
- (D) differential compound

**MCQ 4.34**

The electromagnetic torque  $T_e$  of a drive and its connected load torque  $T_L$  are as shown below. Out of the operating points A, B, C and D, the stable ones are

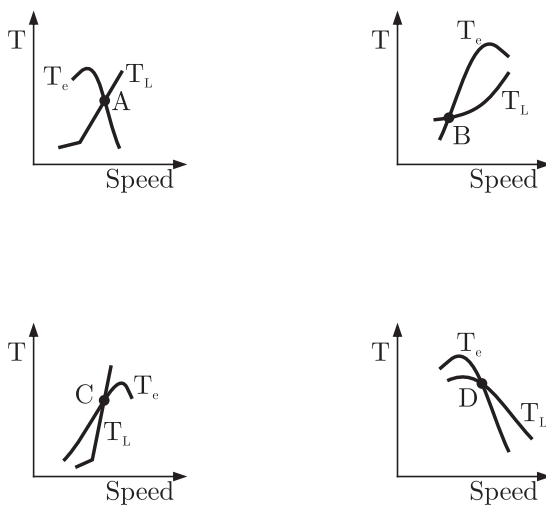

- (A) A, C, D
- (B) B, C
- (C) A, D
- (D) B, C, D

**MCQ 4.35**

A three-phase synchronous motor connected to ac mains is running at full load and unity power factor. If its shaft load is reduced by half, with field current held constant, its new power factor will be

- (A) unity
- (B) leading
- (C) lagging
- (D) dependent on machine parameters

**MCQ 4.36**

A 100 kVA, 415 V(line), star-connected synchronous machine generates rated open circuit voltage of 415 V at a field current of 15 A. The short circuit armature current at a field current of 10 A is equal to the rated armature current. The per unit saturated synchronous reactance is

- (A) 1.731
- (B) 1.5
- (C) 0.666
- (D) 0.577

**MCQ 4.37**

A single-phase, 50 kVA, 250 V/500 V two winding transformer has an efficiency of 95% at full load, unity power factor. If it is re-configured as a 500 V/750 V auto-transformer, its efficiency at its new rated load at unity power factor will be

- (A) 95.752%
- (B) 97.851%
- (C) 98.276%
- (D) 99.241%

**MCQ 4.38**

A three-phase, three-stack, variable reluctance step motor has 20 poles on each rotor and stator stack. The step angle of this step motor is

- (A) 3°
- (B) 6°
- (C) 9°
- (D) 18°

**NOTES**

circuit test, core losses are obtained

- (B) In an open circuit test, current is drawn at high power factor
- (C) In a short circuit test, current is drawn at zero power factor
- (D) In an open circuit test, current is drawn at low power factor

**MCQ 4.44**

For a single phase capacitor start induction motor which of the following statements is valid ?

- (A) The capacitor is used for power factor improvement
- (B) The direction of rotation can be changed by reversing the main winding terminals
- (C) The direction of rotation cannot be changed
- (D) The direction of rotation can be changed by interchanging the supply terminals

**MCQ 4.45**

In a DC machine, which of the following statements is true ?

- (A) Compensating winding is used for neutralizing armature reaction while interpole winding is used for producing residual flux
- (B) Compensating winding is used for neutralizing armature reaction while interpole winding is used for improving commutation
- (C) Compensating winding is used for improving commutation while interpole winding is used for neutralizing armature reaction
- (D) Compensation winding is used for improving commutation while interpole winding is used for producing residual flux

**YEAR 2006**

**TWO MARKS**

**MCQ 4.46**

A 220 V DC machine supplies 20 A at 200 V as a generator. The armature resistance is 0.2 ohm. If the machine is now operated as a motor at same terminal voltage and current but with the flux increased by 10%, the ratio of motor speed to generator speed is

- (A) 0.87
- (B) 0.95
- (C) 0.96
- (D) 1.06

**MCQ 4.47**

A synchronous generator is feeding a zero power factor (lagging) load at rated current. The armature reaction is

- (A) magnetizing (B) demagnetizing  
(C) cross-magnetizing (D) ineffective

**MCQ 4.48**

Two transformers are to be operated in parallel such that they share load in proportion to their kVA ratings. The rating of the first transformer is 500 kVA ratings. The rating of the first transformer is 500 kVA and its pu leakage impedance is 0.05 pu. If the rating of second transformer is 250 kVA, its pu leakage impedance is

- (A) 0.20 (B) 0.10  
(C) 0.05 (D) 0.025

**MCQ 4.49**

The speed of a 4-pole induction motor is controlled by varying the supply frequency while maintaining the ratio of supply voltage to supply frequency ( $V/f$ ) constant. At rated frequency of 50 Hz and rated voltage of 400 V its speed is 1440 rpm. Find the speed at 30 Hz, if the load torque is constant

- (A) 882 rpm (B) 864 rpm  
(C) 840 rpm (D) 828 rpm

**MCQ 4.50**

A 3-phase, 4-pole, 400 V 50 Hz , star connected induction motor has following circuit parameters

$$r_1 = 1.0 \Omega, r'_2 = 0.5 \Omega, X_1 = X'_2 = 1.2 \Omega, X_m = 35 \Omega$$

The starting torque when the motor is started direct-on-line is (use approximate equivalent circuit model)

- (A) 63.6 Nm (B) 74.3 Nm  
(C) 190.8 Nm (D) 222.9 Nm

**MCQ 4.51**

A 3-phase, 10 kW, 400 V, 4-pole, 50Hz, star connected induction motor draws 20 A on full load. Its no load and blocked rotor test data

**MCQ 4.55**

The fifth harmonic component of phase emf(in volts), for a three phase star connection is

- (A) 0 (B) 269  
(C) 281 (D) 808

**Statement for Linked Answer Questions 56 and 57.**

A 300 kVA transformer has 95% efficiency at full load 0.8 p.f. lagging and 96% efficiency at half load, unity p.f.

**MCQ 4.56**

The iron loss ( $P_i$ ) and copper loss ( $P_c$ ) in kW, under full load operation are

- (A)  $P_c = 4.12, P_i = 8.51$  (B)  $P_c = 6.59, P_i = 9.21$   
(C)  $P_c = 8.51, P_i = 4.12$  (D)  $P_c = 12.72, P_i = 3.07$

**MCQ 4.57**

What is the maximum efficiency (in %) at unity p.f. load ?

- (A) 95.1 (B) 96.2  
(C) 96.4 (D) 98.1

**YEAR 2005**

**ONE MARK**

**MCQ 4.58**

The equivalent circuit of a transformer has leakage reactances  $X_1, X_2$  and magnetizing reactance  $X_M$ . Their magnitudes satisfy

- (A)  $X_1 \gg X_2 \gg X_M$  (B)  $X_1 \ll X_2 \ll X_M$   
(C)  $X_1 \approx X_2 \gg X_M$  (D)  $X_1 \approx X_2 \ll X_M$

**MCQ 4.59**

Which three-phase connection can be used in a transformer to introduce a phase difference of  $30^\circ$  between its output and corresponding input line voltages



**NOTES**

- (A) Star-Star (B) Star-Delta  
(C) Delta-Delta (D) Delta-Zigzag

**MCQ 4.60**

On the torque/speed curve of the induction motor shown in the figure four points of operation are marked as W, X, Y and Z. Which one of them represents the operation at a slip greater than 1 ?

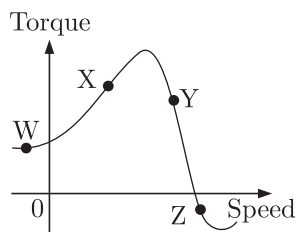

- (A) W (B) X  
(C) Y (D) Z

**MCQ 4.61**

For an induction motor, operation at a slip  $s$ , the ration of gross power output to air gap power is equal to

- (A)  $(1 - s)^2$  (B)  $(1 - s)$   
(C)  $\sqrt{(1 - s)}$  (D)  $(1 - \sqrt{s})$

**YEAR 2005**

**TWO MARKS**

**MCQ 4.62**

Two magnetic poles revolve around a stationary armature carrying two coil ( $c_1 - c_1', c_2 - c_2'$ ) as shown in the figure. Consider the instant when the poles are in a position as shown. Identify the correct statement regarding the polarity of the induced emf at this instant in coil sides  $c_1$  and  $c_2$ .

**NOTES**

**MCQ 4.65**

In relation to DC machines, match the following and choose the correct combination

**List-I**

Performance Variables

P. Armature emf ( $E$ )

Q. Developed torque ( $T$ )

R. Developed power ( $P$ )

**List-II**

Proportional to

1. Flux( $\phi$ ), speed ( $\omega$ ) and armature current ( $I_a$ )

2.  $\phi$  and  $\omega$  only

3.  $\phi$  and  $I_a$  only

4.  $I_a$  and  $\omega$  only

5.  $I_a$  only

**Codes:**

	P	Q	R
(A)	3	3	1
(B)	2	5	4
(C)	3	5	4
(D)	2	3	1

**MCQ 4.66**

Under no load condition, if the applied voltage to an induction motor is reduced from the rated voltage to half the rated value,

(A) the speed decreases and the stator current increases

(B) both the speed and the stator current decreases

(C) the speed and the stator current remain practically constant

(D) there is negligible change in the speed but the stator current decreases

**MCQ 4.67**

A three-phase cage induction motor is started by direct-on-line (DOL) switching at the rated voltage. If the starting current drawn is 6 times the full load current, and the full load slip is 4%, then ratio of the starting developed torque to the full load torque is approximately equal to

(A) 0.24

(B) 1.44

(C) 2.40

(D) 6.00

**NOTES**

**MCQ 4.71**

The power(or torque) angle is close to

- (A) 13.9° (B) 18.3°  
(C) 24.6° (D) 33.0°

**YEAR 2004**

**ONE MARK**

**MCQ 4.72**

A 500 kVA, 3-phase transformer has iron losses of 300 W and full load copper losses of 600 W. The percentage load at which the transformer is expected to have maximum efficiency is

- (A) 50.0% (B) 70.7%  
(C) 141.4% (D) 200.0%

**MCQ 4.73**

For a given stepper motor, the following torque has the highest numerical value

- (A) Detent torque (B) Pull-in torque  
(C) Pull-out torque (D) Holding torque

**MCQ 4.74**

The following motor definitely has a permanent magnet rotor

- (A) DC commutator motor (B) Brushless dc motor  
(C) Stepper motor (D) Reluctance motor

**MCQ 4.75**

The type of single-phase induction motor having the highest power factor at full load is

- (A) shaded pole type (B) split-phase type  
(C) capacitor-start type (D) capacitor-run type

**MCQ 4.76**

The direction of rotation of a 3-phase induction motor is clockwise when it is supplied with 3-phase sinusoidal voltage having phase sequence A-B-C. For counter clockwise rotation of the motor, the phase sequence of the power supply should be

- (A) B-C-A  
(C) A-C-B
- (B) C-A-B  
(D) B-C-A or C-A-B

**MCQ 4.77**

For a linear electromagnetic circuit, the following statement is true

- (A) Field energy is equal to the co-energy  
(B) Field energy is greater than the co-energy  
(C) Field energy is lesser than the co-energy  
(D) Co-energy is zero

**YEAR 2004**

**TWO MARKS**

**MCQ 4.78**

The synchronous speed for the seventh space harmonic mmf wave of a 3-phase, 8-pole, 50 Hz induction machine is

- (A) 107.14 rpm in forward direction  
(B) 107.14 rpm in reverse direction  
(C) 5250 rpm in forward direction  
(D) 5250 rpm in reverse direction

**MCQ 4.79**

A rotating electrical machine its self-inductances of both the stator and the rotor windings, independent of the rotor position will be definitely not develop

- (A) starting torque  
(C) hysteresis torque
- (B) synchronizing torque  
(D) reluctance torque

**MCQ 4.80**

The armature resistance of a permanent magnet dc motor is  $0.8 \Omega$ . At no load, the motor draws 1.5 A from a supply voltage of 25 V and runs at 1500 rpm. The efficiency of the motor while it is operating on load at 1500 rpm drawing a current of 3.5 A from the same source will be

- (A) 48.0%  
(C) 59.2%
- (B) 57.1%  
(D) 88.8%



**NOTES**

voltage of 21.5 kV at 0.85 p.f. The line current when operating at full load rated conditions will be

- (A) 13.43 kA (B) 15.79 kA  
(C) 23.25 kA (D) 27.36 kA

**YEAR 2003**

**ONE MARK**

**MCQ 4.90**

A simple phase transformer has a maximum efficiency of 90% at full load and unity power factor. Efficiency at half load at the same power factor is

- (A) 86.7% (B) 88.26%  
(C) 88.9% (D) 87.8%

**MCQ 4.91**

Group-I lists different applications and Group-II lists the motors for these applications. Match the application with the most suitable motor and choose the right combination among the choices given thereafter

**Group-I**

- P. Food mixer  
Q. Cassette tape recorder  
R. Domestic water pump  
S. Escalator

**Group-II**

1. Permanent magnet dc motor
2. Single-phase induction motor
3. Universal motor
4. Three-phase induction motor
5. DC series motor
6. Stepper motor

**Codes:**

	P	Q	R	S
(A)	3	6	4	5
(B)	1	3	2	4
(C)	3	1	2	4
(D)	3	2	1	4

**MCQ 4.92**

A stand alone engine driven synchronous generator is feeding a partly inductive load. A capacitor is now connected across the load to completely nullify the inductive current. For this operating condition.

- (A) the field current and fuel input have to be reduced
- (B) the field current and fuel input have to be increased
- (C) the field current has to be increased and fuel input left unaltered
- (D) the field current has to be reduced and fuel input left unaltered

**MCQ 4.93**

Curves X and Y in figure denote open circuit and full-load zero power factor(zpf) characteristics of a synchronous generator. Q is a point on the zpf characteristics at 1.0 p.u. voltage. The vertical distance PQ in figure gives the voltage drop across

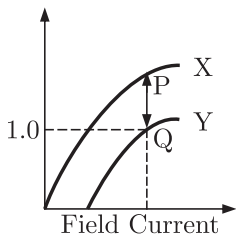

- (A) Synchronous reactance
- (B) Magnetizing reactance
- (C) Potier reactance
- (D) Leakage reactance

**MCQ 4.94**

No-load test on a 3-phase induction motor was conducted at different supply voltage and a plot of input power versus voltage was drawn. This curve was extrapolated to intersect the y-axis. The intersection point yields

- (A) Core loss
- (B) Stator copper loss
- (C) Stray load loss
- (D) Friction and windage loss

**MCQ 4.95**

Figure shows an ideal single-phase transformer. The primary and secondary coils are wound on the core as shown. Turns ratio  $N_1/N_2 = 2$ . The correct phasors of voltages  $E_1, E_2$ , currents  $I_1, I_2$  and core flux  $\Phi$  are as shown in

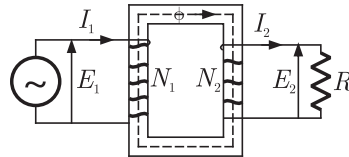

- (A)
- (B)
- (C)
- (D)

**MCQ 4.96**

To conduct load test on a dc shunt motor, it is coupled to a generator which is identical to the motor. The field of the generator is also connected to the same supply source as the motor. The armature of generator is connected to a load resistance. The armature resistance is 0.02 p.u. Armature reaction and mechanical losses can be neglected. With rated voltage across the motor, the load resistance across the generator is adjusted to obtain rated armature current in both motor and generator. The p.u value of this load resistance is

- (A) 1.0 (B) 0.98  
(C) 0.96 (D) 0.94





**NOTES**

**MCQ 4.103**

A single-phase induction motor with only the main winding excited would exhibit the following response at synchronous speed

- (A) Rotor current is zero
- (B) Rotor current is non-zero and is at slip frequency
- (C) Forward and backward rotating fields are equal
- (D) Forward rotating field is more than the backward rotating field

**MCQ 4.104**

A dc series motor driving an electric train faces a constant power load. It is running at rated speed and rated voltage. If the speed has to be brought down to 0.25 p.u. the supply voltage has to be approximately brought down to

- (A) 0.75 p.u
- (B) 0.5 p.u
- (C) 0.25 p.u
- (D) 0.125 p.u

**YEAR 2002**

**ONE MARK**

**MCQ 4.105**

If a 400 V, 50 Hz, star connected, 3-phase squirrel cage induction motor is operated from a 400 V, 75 Hz supply, the torque that the motor can now provide while drawing rated current from the supply

- (A) reduces
- (B) increases
- (C) remains the same
- (D) increases or reduces depending upon the rotor resistance

**MCQ 4.106**

A dc series motor fed from rated supply voltage is over-loaded and its magnetic circuit is saturated. The torque-speed characteristic of this motor will be approximately represented by which curve of figure ?



**MCQ 4.113\***

A single phase 6300 kVA, 50 Hz, 3300 V/ 400 V distribution transformer is connected between two 50 Hz supply systems, A and B as shown in figure. The transformer has 12 and 99 turns in the low and high voltage windings respectively. The magnetizing reactance of the transformer referred to the high voltage side is  $500 \Omega$ . The leakage reactance of the high and low voltage windings are  $1.0 \Omega$  and  $0.012 \Omega$  respectively. Neglect the winding resistance and core losses of the transformer. The Thevenin voltage of system A is 3300 V while that of system B is 400 V. The short circuit reactance of system A and B are  $0.5 \Omega$  and  $0.010 \Omega$  respectively. If no power is transferred between A and B, so that the two system voltages are in phase, find the magnetizing ampere turns of the transformer.

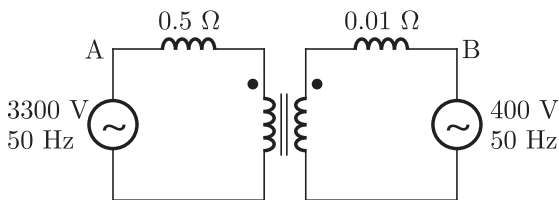

**MCQ 4.114\***

A 440 V, 50 Hz, 6 pole, 960 rpm star connected induction machine has the following per phase parameters referred to the stator :

$$R_s = 0.6 \Omega, R_r = 0.3 \Omega, X_s = 1 \Omega$$

The magnetizing reactance is very high and is neglected. The machine is connected to the 440 V, 50 Hz supply and a certain mechanical load is coupled to it. It is found that the magnitude of the stator current is equal to the rated current of the machine but the machine is running at a speed higher than its rated speed. Find the speed at which the machine is running. Also find the torque developed by the machine.

**MCQ 4.115**

A 415 V, 2-pole, 3-phase, 50 Hz, star connected, non-salient pole synchronous motor has synchronous reactance of  $2 \Omega$  per phase and negligible stator resistance. At a particular field excitation, it draws 20 A at unity power factor from a 415 V, 3-phase, 50 Hz supply. The mechanical load on the motor is now increased till the stator current is equal to 50 A. The field excitation remains unchanged.

**NOTES**

Determine :

- (a) the per phase open circuit voltage  $E_0$
- (b) the developed power for the new operating condition and corresponding power factor.

**YEAR 2001**

**ONE MARK**

**MCQ 4.116**

The core flux of a practical transformer with a resistive load

- (A) is strictly constant with load changes
- (B) increases linearly with load
- (C) increases as the square root of the load
- (D) decreases with increased load

**MCQ 4.117**

$X_d$ ,  $X'_d$  and  $X''_d$  are steady state  $d$ -axis synchronous reactance, transient  $d$ -axis reactance and sub-transient  $d$ -axis reactance of a synchronous machine respectively. Which of the following statements is true ?

- (A)  $X_d > X'_d > X''_d$
- (B)  $X''_d > X'_d > X_d$
- (C)  $X'_d > X''_d > X_d$
- (D)  $X_d > X''_d > X'_d$

**MCQ 4.118**

A 50 Hz balanced three-phase, Y-connected supply is connected to a balanced three-phase Y-connected load. If the instantaneous phase-a of the supply voltage is  $V\cos(\omega t)$  and the phase-a of the load current is  $I\cos(\omega t - \phi)$ , the instantaneous three-phase power is

- (A) a constant with a magnitude of  $VI\cos\phi$
- (B) a constant with a magnitude of  $(3/2)VI\cos\phi$
- (C) time-varying with an average value of  $(3/2)VI\cos\phi$  and a frequency of 100 Hz
- (D) time-varying with an average value of  $VI\cos\phi$  and a frequency of 50 Hz

**MCQ 4.119**

In the protection of transformers, harmonic restraint is used to guard

against

- (A) magnetizing inrush current      (B) unbalanced operation  
(C) lightning                              (D) switching over-voltages

**MCQ 4.120**

In case of an armature controlled separately excited dc motor drive with closed-loop speed control, an inner current loop is useful because it

- (A) limits the speed of the motor to a safe value  
(B) helps in improving the drive energy efficiency  
(C) limits the peak current of the motor to the permissible value  
(D) reduces the steady state speed error

**YEAR 2001**

**TWO MARK**

**MCQ 4.121**

An electric motor with “constant output power” will have a torque-speed characteristics in the form of a

- (A) straight line through the origin  
(B) straight line parallel to the speed axis  
(C) circle about the origin  
(D) rectangular hyperbola

**MCQ 4.122\***

An ideal transformer has a linear  $B/H$  characteristic with a finite slope and a turns ratio of 1 : 1. The primary of the transformer is energized with an ideal current source, producing the signal  $i$  as shown in figure. Sketch the shape (neglecting the scale factor ) of the following signals, labeling the time axis clearly

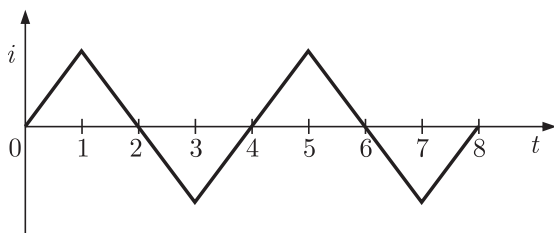

**NOTES**

- (a) the core flux  $\phi_{oc}$  with the secondary of the transformer open
- (b) the open-circuited secondary terminal voltage  $v_2(t)$
- (c) the short-circuited secondary current  $i_2(t)$ , and
- (d) the core flux  $\phi_{sc}$  with the secondary of the transformer short-circuited

**MCQ 4.123\***

In a dc motor running at 2000 rpm, the hysteresis and eddy current losses are 500 W and 200 W respectively. If the flux remains constant, calculate the speed at which the total iron losses are halved.

**MCQ 4.124\***

A dc series motor is rated 230 V, 1000 rpm, 80 A (refer to figure). The series field resistance is  $0.11 \Omega$ , and the armature resistance is  $0.14 \Omega$ . If the flux at an armature current of 20 A is 0.4 times of that under rated condition, calculate the speed at this reduced armature current of 20 A.

**MCQ 4.125\***

A 50 kW synchronous motor is tested by driving it by another motor. When the excitation is not switched on, the driving motor takes 800 W. When the armature is short-circuited and the rated armature current of 10 A is passed through it, the driving motor requires 2500 W. On open-circuiting the armature with rated excitation, the driving motor takes 1800 W. Calculate the efficiency of the synchronous motor at 50% load. Neglect the losses in the driving motor.

**MCQ 4.126\***

Two identical synchronous generators, each of 100 MVA, are working in parallel supplying 100 MVA at 0.8 lagging p.f. at rated voltage. Initially the machines are sharing load equally. If the field current of first generator is reduced by 5% and of the second generator increased by 5%, find the sharing of load (MW and MVAR) between the generators.

Assume  $X_d = X_q = 0.8$  p.u, no field saturation and rated voltage across load. Reasonable approximations may be made.

\*\*\*\*\*

**NOTES**

**SOL 4.4**

**SOL 4.5**

Given no-load speed  $N_1 = 1500$  rpm

$$V_a = 200 \text{ V}, T = 5 \text{ Nm}, N = 1400 \text{ rpm}$$

emf at no load

$$E_{b1} = V_a = 200 \text{ V}$$

$$N \propto E_b \Rightarrow \frac{N_1}{N_2} = \frac{E_{b1}}{E_{b2}}$$

$$E_{b2} = \left(\frac{N_2}{N_1}\right) E_{b1} = \frac{1400}{1500} \times 200 = 186.67 \text{ V}$$

$$\therefore T = E_b (I_a / \omega) \Rightarrow \frac{186.67 \times 60}{2\pi \times 1400} I_a = 5$$

$$I_a = 3.926 \text{ A}$$

$$\therefore V = E_b + I_a R_a$$

$$R_a = \frac{V_a - E_b}{I_a} = \frac{200 - 186.67}{3.926} = 3.4 \text{ } \Omega$$

Hence (B) is correct option.

**SOL 4.6**

$$T = 2.5 \text{ Nm at } 1400 \text{ rpm}$$

than  $V = ?$

$$\therefore T = \frac{E_b I_b}{\omega}$$

$$2.5 = \frac{186.6 \times I_a \times 60}{2\pi \times 1400}$$

$$I_a = 1.963 \text{ A}$$

$$V = E_b + I_a R_a$$

$$= 186.6 + 1.963 \times 3.4$$

$$= 193.34 \text{ V}$$

Hence (B) is correct option.

**SOL 4.7**

Given field excitation of = 20 A

Armature current = 400 A

Short circuit and terminal voltage = 200 V

On open circuit, load current = 200 A



So, Internal resistance =  $\frac{2000}{400} = 5 \Omega$

Internal vol. drop =  $5 \times 200$   
= 1000 V

Hence (D) is correct option.

**SOL 4.8**

Given single-phase iron core transformer has both the vertical arms of cross section area  $20 \text{ cm}^2$ , and both the horizontal arms of cross section are  $10 \text{ cm}^2$

So, Inductance =  $\frac{NBA}{l}$  (proportional to cross section area)

When cross section became half, inductance became half.

Hence (C) is correct option.

**SOL 4.9**

Given 3-phase squirrel cage induction motor.

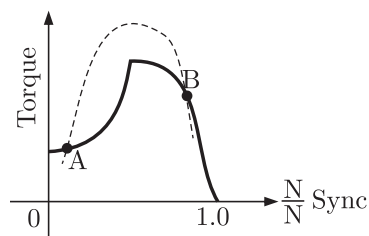

At point A if speed  $\uparrow$ , Torque  $\uparrow$   
speed  $\downarrow$ , Torque  $\downarrow$

So A is stable.

At point B if speed  $\uparrow$  Load torque  $\downarrow$

So B is un-stable.

Hence (A) is correct option.

**SOL 4.10**

**SOL 4.11**

Peak voltage across A and B with S open is

$V = m \frac{di}{dt} = m \times (\text{slope of } I - t)$

**NOTES**

$$= \frac{400}{\pi} \times 10^{-3} \times \left[ \frac{10}{5 \times 10^{-3}} \right] = \frac{800}{\pi} \text{ V}$$

Hence (D) is correct option.

**SOL 4.12**

**SOL 4.13**

Wave form  $V_{A'B'}$

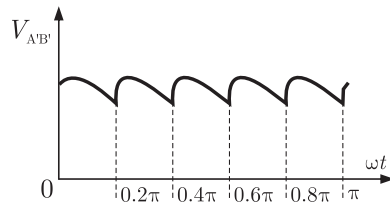

Hence (A) is correct option.

**SOL 4.14**

When both S1 and S2 open, star connection consists 3<sup>rd</sup> harmonics in line current due to hysteresis A saturation.

Hence (B) is correct option.

**SOL 4.15**

Since S2 closed and S1 open, so it will be open delta connection and output will be sinusoidal at fundamental frequency.

Hence (A) is correct option.

**SOL 4.16**

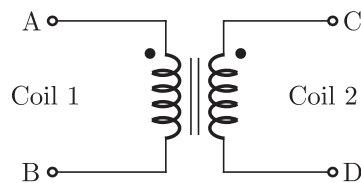

$$N_1 = 4000$$

$$N_2 = 6000$$

$$I = 25 \text{ A}$$

$$V = 400 \text{ V}, f = 50 \text{ Hz}$$

fraction and windage losses = 1050 W

Core losses = 1200 W = 1.2 kW

So,

$$\begin{aligned} \text{Input power in stator} &= \sqrt{3} \times 400 \times 50 \times 0.8 \\ &= 27.71 \text{ kW} \end{aligned}$$

$$\begin{aligned} \text{Air gap power} &= 27.71 - 1.5 - 1.2 \\ &= 25.01 \text{ kW} \end{aligned}$$

Hence (C) is correct option.

**SOL 4.24**

Induced emf in secondary =  $-N_2 \frac{d\phi}{dt}$

During  $-0 < t < 1$

$$E_1 = - (100) \frac{d\phi}{dt} = -12 \text{ V}$$

$E_1$  and  $E_2$  are in opposition

$$E_2 = 2E_1 = 24 \text{ V}$$

During time  $1 < t < 2$

$$\frac{d\phi}{dt} = 0, \text{ then } E_1 = E_2 = 0$$

During  $2 < t < 2.5$

$$E_1 = - (100) \frac{d\phi}{dt} = -24 \text{ V}$$

Then

$$E_2 = -0 - 48 \text{ V}$$

Hence (A) is correct option.

**SOL 4.25**

Given 400 V, 50 Hz, 4-Pole, 1400 rpm star connected squirrel cage induction motor.

$$R = 1.00 \Omega, X_s = X'_r = 1.5 \Omega$$

So,

for max. torque slip

$$S_m = \frac{R'_r}{X_{sm} + X'_{rm}}$$

for starting torque  $S_m = 1$

Then

**NOTES**

$$X_{sm} + X'_{rm} = R'_r$$

$$2\pi f_m L_s + 0.2\pi f_m L'_r = 1$$

Frequency at max. torque

$$f_m = \frac{1}{2\pi(L_s + L'_r)}$$

$$L_s = \frac{X_s}{2\pi \times 50} = \frac{1.5}{2\pi \times 50}$$

$$L'_r = \frac{1.5}{2\pi \times 50}$$

$$f_m = \frac{1}{\frac{1.5}{50} + \frac{1.5}{50}} = \frac{50}{3}$$

$$f_m = 16.7 \text{ Hz}$$

In const  $V/f$  control method

$$\frac{V_1}{f_1} = \frac{400}{50} = 8$$

$$\therefore \frac{V_2}{f_2} = 8$$

So

$$V_2 = f_2 \times 8$$

$$= 16.7 \times 8$$

$$V_2 = 133.3 \text{ V}$$

Hence (B) is correct option.

**SOL 4.26**

Given 3- $\phi$ , 440 V, 50 Hz, 4-Pole slip ring motor

Motor is coupled to 220 V

$$N = 1410 \text{ rpm}, W_1 = 1800 \text{ W}, W_2 = 200 \text{ W}$$

So,

$$N_s = \frac{120f}{P}$$

$$= \frac{120 \times 50}{4} = 1500 \text{ rpm}$$

$$\text{Relative speed} = 1500 - 1410$$

$$= 90 \text{ rpm in the direction of rotation.}$$

Hence (A) is correct option.

**SOL 4.27**

Neglecting losses of both machines

$$\text{Slip}(S) = \frac{N_s - N}{N_s}$$

$$= \frac{1500 - 1410}{1500} = 0.06$$

total power input to induction motor is

$$P_{\text{in}} = 1800 - 200 = 1600 \text{ W}$$

Output power of induction motor

$$\begin{aligned} P_{\text{out}} &= (1 - S) P_{\text{in}} \\ &= (1 - 0.06) 1600 \\ &= 1504 \text{ W} \end{aligned}$$

Losses are neglected so dc generator input power = output power  
= 1504 W

So,

$$I^2 R = 1504$$

$$I = \sqrt{\frac{1504}{10}} = 12.26 \text{ A}$$

Hence (C) is correct option.

**SOL 4.28**

Given:  $V = 240 \text{ V}$ , dc shunt motor

$$I = 15 \text{ A}$$

Rated load at a speed = 80 rad/s

Armature Resistance =  $0.5 \Omega$

Field winding Resistance =  $80 \Omega$

So,

$$E = 240 - 12 \times 0.5$$

$$E = 234$$

$$V_{\text{plugging}} = V + E$$

$$= 240 + 234$$

$$= 474 \text{ V}$$

Hence (D) is correct option.

**SOL 4.29**

External Resistance to be added in the armature circuit to limit the armature current to 125%.

$$\text{So } I_a = 12 \times 1.25 = \frac{474}{R_a + R_{\text{external}}}$$

$$R_a + R_{\text{external}} = 31.6$$

$$R_{\text{external}} = 31.1 \Omega$$

Hence (A) is correct option.

**NOTES**

**SOL 4.30**

A synchronous motor is connected to an infinite bus at 1.0 p.u. voltage and 0.6 p.u. current at unity power factor. Reactance is 1.0 p.u. and resistance is negligible.

So,

$$V = 1 \angle 0^\circ \text{ p.u.}$$

$$I_a = 0.6 \angle 0^\circ \text{ p.u.}$$

$$Z_s = R_a + jX_s = 0 + j1 = 1 \angle 90^\circ \text{ p.u.}$$

$$V = E \angle \delta + I_a Z_s = 1 \angle 0^\circ - 0.6 \angle 0^\circ \times 1 \angle 90^\circ$$

$$E \angle \delta = 1.166 \angle -30.96^\circ \text{ p.u.}$$

Excitation voltage = 1.17 p.u.

Load angle ( $\delta$ ) = 30.96°(lagging)

Hence (D) is correct option.

**SOL 4.31**

**SOL 4.32**

In transformer zero voltage regulation at full load gives leading power factor.

Hence (C) is correct option.

**SOL 4.33**

Speed-armature current characteristic of a dc motor is shown as following

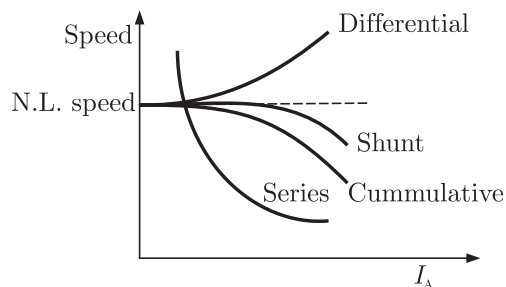

The shunt motor provides speed regulation at full load without any controller.

Hence (B) is correct option.

**NOTES**

So  $W_{cu} + W_i = 2.631$

Reconfigured as a 500 V/750 V auto-transformer

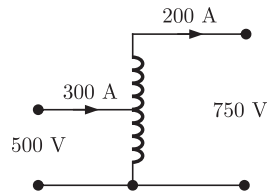

auto-transformer efficiency

$$\eta = \frac{150}{150 + 2.631}$$

$$= 98.276\%$$

Hence (C) is correct option.

**SOL 4.38**

Given 3- $\phi$ , 3-stack

Variable reluctance step motor has 20-poles

$$\text{Step angle} = \frac{360}{3 \times 20} = 6^\circ$$

Hence (B) is correct option.

**SOL 4.39**

Given a 3- $\phi$  squirrel cage induction motor starting torque is 150% and maximum torque 300%

So

$$T_{\text{Start}} = 1.5 T_{\text{FL}}$$

$$T_{\text{max}} = 3 T_{\text{FL}}$$

Then

$$\frac{T_{\text{Start}}}{T_{\text{max}}} = \frac{1}{2} \quad \dots(1)$$

$$\frac{T_{\text{Start}}}{T_{\text{max}}} = \frac{2S_{\text{max}}}{S_{\text{max}}^2 + 1^2} \quad \dots(2)$$

from equation (1) and (2)

$$\frac{2S_{\text{max}}}{S_{\text{max}}^2 + 1} = \frac{1}{2}$$

$$S_{\text{max}}^2 - 4S_{\text{max}} + 1 = 0$$

So

$$S_{\text{max}} = 26.786\%$$

Hence (D) is correct option.

**SOL 4.40**

Given 3- $\phi$  squirrel cage induction motor has a starting current of seven the full load current and full load slip is 5%

$$\begin{aligned} I_{St} &= 7I_{F1} \\ S_{F1} &= 5\% \\ \frac{T_{St}}{T_{F1}} &= \left(\frac{I_{St}}{I_{F1}}\right)^2 \times x^2 \times S_{F1} \\ 1.5 &= (7)^2 \times x^2 \times 0.05 \\ x &= 78.252\% \end{aligned}$$

Hence (C) is correct option.

**SOL 4.41**

Star delta starter is used to start this induction motor  
So

$$\begin{aligned} \frac{T_{St}}{T_{F1}} &= \frac{1}{3} \times \left(\frac{I_{St}}{I_{F1}}\right)^2 \times S_{F1} \\ &= \frac{1}{3} \times 7^2 \times 0.05 \\ \frac{T_{St}}{T_{F1}} &= 0.816 \end{aligned}$$

Hence (B) is correct option.

**SOL 4.42**

Given starting torque is 0.5 p.u.  
So,

$$\begin{aligned} \frac{T_{St}}{T_{F1}} &= \left(\frac{I_{sc}}{I_{F1}}\right)^2 \times S_{F1} \\ 0.5 &= \left(\frac{I_{sc}}{I_{F1}}\right)^2 \times 0.05 \end{aligned}$$

Per unit starting current

$$\frac{I_{sc}}{I_{F1}} = \sqrt{\frac{0.5}{0.05}} = 3.16 \text{ A}$$

Hence (C) is correct option.

**SOL 4.43**

In transformer, in open circuit test, current is drawn at low power factor but in short circuit test current drawn at high power factor.  
Hence (D) is correct option.



**NOTES**

**SOL 4.44**

A single-phase capacitor start induction motor. It has cage rotor and its stator has two windings.

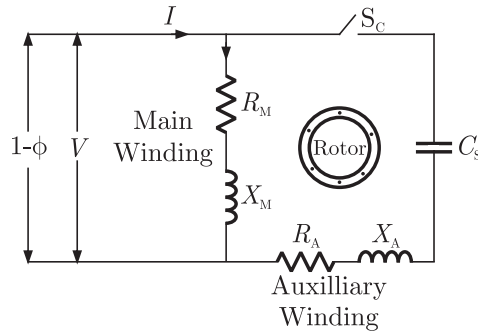

The two windings are displaced  $90^\circ$  in space. The direction of rotation can be changed by reversing the main winding terminals.

Hence (B) is correct option.

**SOL 4.45**

In DC motor, compensating winding is used for neutralizing armature reactance while interpole winding is used for improving commutation. Interpoles generate voltage necessary to neutralize the e.m.f of self induction in the armature coils undergoing commutation. Interpoles have a polarity opposite to that of main pole in the direction of rotation of armature.

Hence (B) is correct option.

**SOL 4.46**

Given: A 230 V, DC machine, 20 A at 200 V as a generator.

$$R_a = 0.2 \Omega$$

The machine operated as a motor at same terminal voltage and current, flux increased by 10%

So for generator

$$\begin{aligned} E_g &= V + I_a R_a \\ &= 200 + 20 \times 0.2 \end{aligned}$$

$$E_g = 204 \text{ volt}$$

for motor  $E_m = V - I_a R_a$

$$= 200 - 20 \times 0.2$$

$$E_m = 196 \text{ volt}$$

$$\begin{aligned} \text{So } \frac{E_g}{E_m} &= \frac{N_g}{N_m} \times \frac{\phi_g}{\phi_m} \\ \frac{204}{196} &= \frac{N_g}{N_m} \times \frac{1}{1.1} \\ \frac{N_m}{N_g} &= \frac{196}{204 \times 1.1} = 0.87 \end{aligned}$$

Hence (A) is correct option.

**SOL 4.47**

A synchronous generator is feeding a zero power factor(lagging) load at rated current then the armature reaction is demagnetizing.

Hence (B) is correct option.

**SOL 4.48**

Given the rating of first transformer is 500 kVA

Per unit leakage impedance is 0.05 p.u.

Rating of second transformer is 250 kVA

So,

$$\text{Per unit impedance} = \frac{\text{actual impedance}}{\text{base impedance}}$$

and,

$$\text{Per unit leakage impedance} \propto \frac{1}{\text{kVA}}$$

Then

$$\begin{aligned} 500 \text{ kVA} \times 0.05 &= 250 \text{ kVA} \times x \\ x &= \frac{500}{250} \times 0.05 = 0.1 \text{ p.u.} \end{aligned}$$

Hence (B) is correct option.

**SOL 4.49**

Given speed of a 4-pole induction motor is controlled by varying the supply frequency when the ratio of supply voltage and frequency is constant.

$$f = 50 \text{ Hz}, V = 400 \text{ V}, N = 1440 \text{ rpm}$$

$$\text{So } V \propto f$$

$$\frac{V_1}{V_2} = \frac{f_1}{f_2}$$

$$V_2 = 400 \times \frac{30}{50} = 240 \text{ V}$$

**NOTES**

$$I_a = 4.8932$$

$$\text{Load (\%)} = \frac{4.8932}{7.22} = 67.83 \%$$

Hence (A) is correct option.

**SOL 4.53**

Given  $P = 4$ ,  $f = 50$  Hz

Slots = 48, each coil has 10 turns

Short pitched by an angle( $\alpha$ ) to  $36^\circ$  electrical

Flux per pole = 0.05 Wb

So,

$$E_{ph} = 4.44 f \phi T_{ph} K_w$$

$$\text{Slot/Pole/ph} = \frac{48}{4 \times 3} = 4$$

$$\text{Slot/Pole} = \frac{48}{4} = 12$$

$$\text{Slot angle} = \frac{180}{12} = 15^\circ$$

$$K_d = \frac{\sin(4 \times 15/2)}{4 \sin(15/2)}$$

$$= 0.957$$

$$K_p = \cos \frac{\alpha}{2}$$

$$= \cos 18^\circ = 0.951$$

In double layer wdg

No. of coil = No of slots

$$\text{No. of turns/ph} = \frac{48 \times 10}{3} = 160$$

Then

$$E_{ph} = 4.44 \times 0.025 \times 50 \times 0.957 \times 0.951 \times 160$$

$$E_{ph} = 808 \text{ V}$$

$$E_L = \sqrt{3} \times 808$$

$$E_L = 1400 \text{ V (approximate)}$$

Hence (C) is correct option.

**SOL 4.54**

line to line induced voltage, so in 2 phase winding

Slot/ pole/ph = 6

$$T_{ph} = \frac{480}{2} = 240$$

$$\text{Slot angle} = \frac{180 \times 4}{48} = 15^\circ$$

$$K_d = \frac{\sin 6 \times (15/2)}{6 \sin(15/2)}$$

$$K_d = 0.903$$

$$K_p = \cos\left(\frac{36}{2}\right) = 0.951$$

$$E_{ph} = 4.44 \times 0.025 \times 50 \times 240 \times 0.951 \times 0.903$$

$$E_{ph} = 1143$$

Hence (A) is correct option.

**SOL 4.55**

Fifth harmonic component of phase emf

So

$$\text{Angle} = \frac{180}{5} = 36^\circ$$

the phase emf of fifth harmonic is zero.

Hence (A) is correct option.

**SOL 4.56**

Given that:

A 300 kVA transformer

Efficiency at full load is 95% and 0.8 p.f. lagging

96% efficiency at half load and unity power factor

So

For 1<sup>st</sup> condition for full load

$$95\% = \frac{\text{kVA} \times 0.8}{\text{kVA} \times 0.8 + W_{cu} + W_i} \quad \dots(1)$$

Second unity power factor half load

$$96\% = \frac{\text{kVA} \times 0.5}{\text{kVA} \times 0.5 + W_{cu} + W_i} \quad \dots(2)$$

So

$$W_{cu} + W_i = 12.63$$

$$0.25 W_{cu} + 0.96 W_i = 6.25$$

Then

$$W_{cu} = 8.51, W_i = 4.118$$

Hence (C) is correct option.

**NOTES**

**SOL 4.57**

$$\text{Efficiency } (\eta) = \frac{X \times \text{p.f.} \times \text{kVA}}{X \times \text{kVA} + W_i + W_{cu} \times X^2}$$

So

$$X = \sqrt{\frac{4.118}{8.51}} = 0.6956$$

$$\eta\% = \frac{0.6956 \times 1 \times 300}{0.6956 \times 300 + 4.118 + 8.51 \times (0.6956)^2}$$

$$\eta = 96.20\%$$

Hence (B) is correct option.

**SOL 4.58**

The leakage reactances  $X_1$ , and  $X_2'$  are equal and magnetizing reactance  $X_m$  is higher than  $X_1$ , and  $X_2'$

$$X_1 \approx X_2' \ll X_m$$

Hence (D) is correct option.

**SOL 4.59**

Three phase star delta connection of transformer induces a phase difference of  $30^\circ$  between output and input line voltage.

Hence (B) is correct option.

**SOL 4.60**

Given torque/speed curve of the induction motor

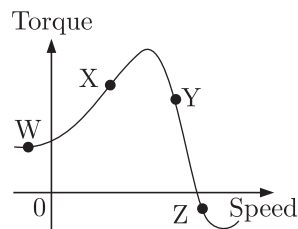

When the speed of the motor is in forward direction then slip varies from 0 to 1 but when speed of motor is in reverse direction or negative then slip is greater than 1. So at point W slip is greater than 1.

Hence (A) is correct option.

**SOL 4.61**

For an induction motor the ratio of gross power output to air-gap is

**NOTES**

the rated voltage on open to the rated armature current.  
Hence (C) is correct option.

**SOL 4.65**

In DC motor

$$E = PN\phi\left(\frac{Z}{A}\right)$$

or

$$E = K\phi\omega_n$$

So

Armature emf  $E$  depends upon  $\phi$  and  $\omega$  only.  
and torque developed depends upon

$$T = \frac{PZ\phi I_a}{2\pi A}$$

So, torque( $T$ ) is depends of  $\phi$  and  $I_a$  and developed power( $P$ ) is depend of flux  $\phi$ , speed  $\omega$  and armature current  $I_a$ .

Hence (D) is correct option.

**SOL 4.66**

Given a three-phase cage induction motor is started by direct on line switching at rated voltage. The starting current drawn is 6 time the full load current.

Full load slip = 4%

So

$$\begin{aligned} \left(\frac{T_{St}}{T_{Fl}}\right) &= \left(\frac{I_{St}}{I_{Fl}}\right)^2 \times S_{Fl} \\ &= (6)^2 \times 0.04 = 1.44 \end{aligned}$$

Hence (B) is correct option.

**SOL 4.67**

Given single-phase induction motor driving a fan load, the resistance rotor is high

So

$$E_b = V - I_a R_a \quad \dots(1)$$

$$\therefore P_{mech} = E_a I_a$$

$$\tau = \frac{P_{mech}}{\omega_m} \quad \dots(2)$$

From equation (1) and (2) the high resistance of rotor then the motor achieves quick acceleration and torque of starting is increase.

Hence (B) is correct option.

**SOL 4.68**

Given  $V/f$  control of induction motor, the maximum developed torque remains same  
we have,

$$E = 4.44K_w f \phi T_1$$

If the stator voltage drop is neglected the terminal voltage  $E_1$ . To avoid saturation and to minimize losses motor is operated at rated airgap flux by varying terminal voltage with frequency. So as to maintain ( $V/f$ ) ratio constant at the rated value, the magnetic flux is maintained almost constant at the rated value which keeps maximum torque constant.

Hence (A) is correct option.

**SOL 4.69**

Given

$$P = 1000 \text{ kVA}, 6.6 \text{ kV}$$

Reactance =  $20 \Omega$  and neglecting the armature resistance at full load and unity power factor

So

$$P = \sqrt{3} V_L I_L$$

$$I = \frac{1000}{\sqrt{3} \times 6.6} = 87.47 \text{ A}$$

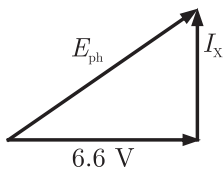

So,

$$IX = 87.47 \times 20 = 1.75 \text{ kV}$$

$$E_{ph}^2 = \left(\frac{6.5}{\sqrt{3}}\right)^2 + (1.75)^2$$

$$E_{ph} = \sqrt{\left(\frac{6.5}{\sqrt{3}}\right)^2 + (1.75)^2}$$

$$E_{ph} = 4.2 \text{ kV}$$

$$E_L = \sqrt{3} E_{ph}$$

$$E_L = 1.732 \times 4.2$$

$\therefore$  Star connection

**NOTES**

$$E_L = 7.26 \text{ kV}$$

Hence (B) is correct option.

**SOL 4.70**

$$\text{Torque angle } \alpha_z = \tan^{-1}\left(\frac{X_s}{R_a}\right)$$

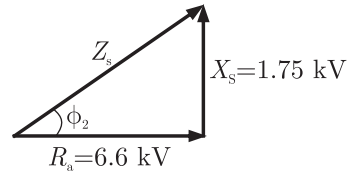

$$\alpha_z = \tan^{-1}\left(\frac{\sqrt{3} \times 1.75}{6.6}\right)$$

$$\alpha_z = 24.6^\circ$$

Hence (C) is correct option.

**SOL 4.71**

Given that

transformer rating is 500 kVA

Iron losses = 300 W

full load copper losses = 600 W

maximum efficiency condition

$$W_i = X^2 W_c$$

so,

$$X = \sqrt{\frac{W_i}{W_c}}$$

$$= \sqrt{\frac{300}{600}}$$

$$\sqrt{1/2}$$

$$0.707$$

$$\text{efficiency}\% = 0.707 \times 100$$

$$= 70.7\%$$

Hence (B) is correct option.

**SOL 4.72**

Stepper motor is rotated in steps, when the supply is connected then the torque is produced in it. The higher value of torque is pull out



$$= (3.5)^2 \times 0.8 = 9.8 \text{ W}$$

Total losses = No load losses + iron losses

$$= 35.7 + 9.8 = 45.5 \text{ W}$$

Total power  $P = VI$

$$P = 25 \times 3.5$$

$$P = 87.5 \text{ W}$$

$$\text{Efficiency} = \frac{\text{output}}{\text{input}}$$

$$\eta = \frac{\text{total power} - \text{losses}}{\text{total power}}$$

$$= \frac{87.5 - 45.5}{87.5} \times 100 = 48.0\%$$

Hence (A) is correct option.

**SOL 4.80**

Given that 50 kVA, 3300/230 V, 1- $\phi$  transform

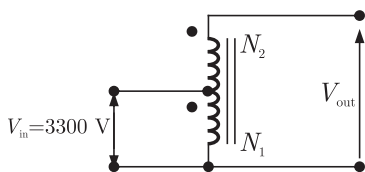

$$V_{in} = 3300 \text{ V}$$

$$V_{out} = 3300 + 230 = 3530 \text{ V}$$

Output current  $I_2$  and output voltage 230 V

So

$$I_2 = \frac{50 \times 10^3}{230} = 217.4 \text{ A}$$

When the output voltage is  $V_{out}$  then kVA rating of auto transformer will be

$$\begin{aligned} I_2 &= 3530 \times 217.4 \\ &= 767.42 \text{ kVA} \end{aligned}$$

Hence (D) is correct option.

**SOL 4.81**

Given that 100 kVA, 11000/400 V, Delta-star distribution transformer resistance is 0.02 pu and reactance is 0.07 pu

So

$$\text{pu impedance } Z_{pu} = 0.02 + j0.07$$

Base impedance referred to primary

**NOTES**

$$Z_{\text{Base}} = \frac{V_P^2}{V_L I_L / 3} = \frac{(11 \times 10^3)^2}{\frac{100 \times 10^3}{3}} = 3630 \Omega$$

The phase impedance referred to primary

$$\begin{aligned} Z_{\text{primary}} &= Z_{\text{pu}} \times Z_{\text{Base}} \\ &= (0.02 + j0.07)(3630) \\ &= 72.6 + j254.1 \end{aligned}$$

Hence (D) is correct option.

**SOL 4.82**

Given that

230 V, 50 Hz, 4-Pole, capacitor-start induction motor

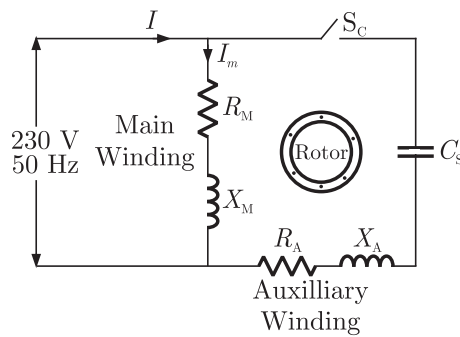

$$\begin{aligned} Z_m &= R_m + jX_m \\ &= 6.0 + j4.0 \Omega \end{aligned}$$

$$\begin{aligned} Z_A &= R_A + jX_A \\ &= 8.0 + j6.0 \Omega \end{aligned}$$

Phase angle of main winding

$$\begin{aligned} \angle I_m &= \angle -Z_m \\ &= -\angle (6 + j4) \\ &= -\angle 33.7^\circ \end{aligned}$$

So angle of the auxiliary winding when the capacitor is in series.

$$\begin{aligned} \angle I_A &= -\angle (8 + j6) + \angle \frac{1}{j\omega C} \\ &= \angle (8 + j6) - \angle \frac{j}{\omega C} \end{aligned}$$

$$\alpha = \angle I_A - \angle I_m$$

So

$$90 = -\tan^{-1} \left[ \left( \frac{6 - \frac{1}{\omega C}}{8} \right) - (-33.7) \right]$$

$$\frac{1}{\omega C} = 18$$

So

$$C = \frac{1}{18 \times 2\pi f} = \frac{1}{18 \times 2 \times 3.14 \times 50}$$

$$= 176.8 \mu\text{F}$$

Hence (A) is correct option.

$$\therefore \omega = 2\pi f$$

**SOL 4.83**

Given that the armature has per phase synchronous reactance of  $1.7 \Omega$  and two alternator is connected in parallel

So,



both alternator voltage are in phase

So,

$$E_{f1} = \frac{3300}{\sqrt{3}}$$

$$E_{f2} = \frac{3200}{\sqrt{3}}$$

Synchronizing current or circulating current

$$= \frac{E_C}{T_{s1} + T_{s2}}$$

Reactance of both alternator are same

So

$$= \frac{E_{f1} - E_{f2}}{T_{s1} + T_{s2}}$$

$$= \frac{1}{\sqrt{3}} \left( \frac{3300 - 3200}{1.7 + 1.7} \right)$$

$$= 16.98 \text{ A}$$

Hence (A) is correct option.

**SOL 4.84**

Given  $V = 400 \text{ V}$ ,  $15 \text{ kW}$  power and  $P = 4$

$f = 50 \text{ Hz}$ , Full load slip ( $S$ ) = 4%

So

$$N_s = \frac{120f}{P}$$

**NOTES**

$$= \frac{(L.F) \cos \phi_2}{(L.F) \cos \phi_2 + P_{i(Pu)} + P_c}$$

where  $L.F.$  is the load factor.

At full load, load factor is

$$L.F. = \sqrt{\frac{P_i}{P_c}} = 1$$

$\cos \phi_2 = 1$  at unity power factor

so, 
$$90\% = \frac{1 \times 1}{1 + 2P_i}$$

$$P_i = 0.0555 \text{ MVA}$$

At half load, load factor is

$$L.F = \frac{1}{2} = .5$$

So,

$$\eta = \frac{0.5 \times 1}{0.5 \times 0.0555 \times (0.5)^2 + 0.0555} \times 100$$

$$\eta = 87.8\%$$

Hence (D) is correct option.

**SOL 4.90**

In food mixer the universal motor is used and in cassette tap recorder permanent magnet DC motor is used. The Domestic water pump used the single and three phase induction motor and escalator used the three phase induction motor.

Hence (C) is correct option.

**SOL 4.91**

Given a engine drive synchronous generator is feeding a partly inductive load. A capacitor is connected across the load to completely nullify the inductive current. Then the motor field current has to be reduced and fuel input left unaltered.

Hence (D) is correct option.

$$V_3 = 100 \text{ V}$$

so current in secondary winding

$$I_2 = \frac{V_2}{R} = \frac{200}{10}$$

$$I_2 = 20 \text{ A}$$

The current in third winding when the capacitor is connected  
so

$$I_3 = \frac{V_3}{-jX_c} = \frac{100}{-j2.5} = j40$$

When the secondary winding current  $I_2$  is referred to primary side  
i.e  $I_1'$

So

$$\frac{I_1'}{I_2} = \frac{N_2}{N_1} = \frac{2}{4}$$

$$I_1' = \frac{20}{2} = 10 \text{ A}$$

and winding third current  $I_3$  is referred to Primary side i.e  $I_1''$ .  $I_3$  flows  
to opposite to  $I_1$

So

$$\frac{I_1''}{-I_3} = \frac{N_3}{N_1} = \frac{1}{4}$$

$$I_1'' = -j10$$

So total current in primary winding is

$$\begin{aligned} I_1 &= I_1' + I_1'' \\ &= 10 - j10 \text{ A} \end{aligned}$$

Hence (D) is correct option.

**SOL 4.98**

Given that:

- P Stator winding current is dc, rotor winding current is ac
- Q Stator winding current is ac, rotor winding current is dc
- R Stator winding current is ac, rotor winding current is ac
- S Stator has salient pole and rotor has commutator
- T Rotor has salient pole and slip rings and stator is cylindrical
- U Both stator and rotor have poly-phase windings

So

DC motor/machines:

The stator winding is connected to dc supply and rotor winding  
flows ac current. Stator is made of salient pole and Commutator is

**NOTES**

connected to the rotor so rotor winding is supply ac power.

Induction machines:

In induction motor the ac supply is connected to stator winding and rotor and stator are made of poly-phase windings.

Synchronous machines:

In this type machines the stator is connected to ac supply but rotor winding is excited by dc supply. The rotor is made of both salient pole and slip rings and stator is made of cylindrical.

Hence (A) is correct option.

**SOL 4.99**

Given that

$F_s$  is the peak value of stator mmf axis.  $F_r$  is the peak value of rotor mmf axis. The rotor mmf lags stator mmf by space angle  $\delta$ . The direction of torque acting on the rotor is clockwise or counter clockwise.

When the opposite pole is produced in same half portion of stator and rotor then the rotor moves. So portion of stator is north-pole in ABC and rotor abc is produced south pole as well as portion surface CDA is produced south pole and the rotor cda is produced North pole.

The torque direction of the rotor is clock wise and torque at surface is in counter clockwise direction.

Hence (C) is correct option.

**SOL 4.100**

Given that:

A 4-pole, 3- $\phi$ , double layer winding has 36 slots stator with 60° phase spread, coil span is 7 short pitched

so,

$$\begin{aligned}\text{Pole pitch} &= \frac{\text{slot}}{\text{pole}} \\ &= \frac{36}{4} = 9\end{aligned}$$

$$\text{Slot/pole/phase} = 3$$

so,

3-slots in one phase, if it is chorded by 2 slots then

Out of 3 → 2 have different phase

Out of 36 → 24 have different phase.  
Hence (A) is correct option.

**SOL 4.101**

Given that:

3- $\phi$  induction motor is driving a constant load torque at rated voltage and frequency. Voltage and frequency are halved and stator resistance, leakage reactance and core losses are ignored.

Then the motor synchronous speed and actual speed difference are same.

$$N_s = \frac{120f}{P}$$

The leakage reactance are ignored then the air gap flux remains same and the stator resistance are ignored then the stator current remain same.

Hence (B) is correct option.

**SOL 4.102**

Given that:

1- $\phi$  induction motor main winding excited then the rotating field of motor changes, the forward rotating field of motor is greater then the back ward rotating field.

Hence (D) is correct option.

**SOL 4.103**

Given that:

A dc series motor driving a constant power load running at rated speed and rated voltage. It's speed brought down 0.25 pu. Then

Emf equation of dc series motor

$$E = V - (R_a + R_{se})$$

$$R_a + R_{se} = R$$

so, 
$$E = V - IR$$
  
$$= K\phi N$$

then 
$$N = \frac{E}{K\phi}$$

In series motor  $\phi \propto I$

so, 
$$N = \frac{V - IR}{KI}$$

At constant power load

**NOTES**

$$E \times I = T \times W = \text{Const} \quad \dots(1)$$

$$T = K\phi I = KI^2 \quad \dots(2)$$

If  $W$  is decreased then torque increases to maintain power constant.

$$T \propto I^2$$

$$W = \frac{1}{4} \text{ then } T = 4$$

So current is increased 2 time and voltage brought down to 0.5 pu.  
Hence (B) is correct option.

**SOL 4.104**

Given 400 V, 50 Hz, Y-connected, 3- $\phi$  squirrel cage induction motor operated from 400 V, 75 Hz supply. Than Torque is decreased.

$\therefore$  Machine is rated at 400 V, 50 Hz

and it is operated from 400 V, 75 Hz

so, speed of Motor will increase as  $N = \frac{120f}{P} \Rightarrow N \propto f$

and we know Torque in induction motor

$$T_e = \frac{3}{W_s} I_2^2 \frac{R_2}{S} \Rightarrow T_e \propto \frac{1}{N}$$

If speed increases, torque decreases.

Hence (A) is correct option.

**SOL 4.105**

Motor is overloaded, and magnetic circuit is saturated. Than Torque speed characteristics become linear at saturated region.

as shown in figure

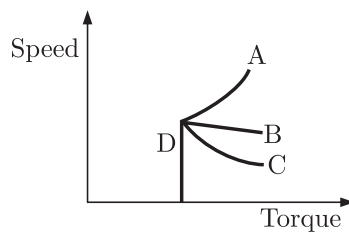

actual torque-speed characteristics is given by curve B.

Hence (B) is correct option.

**SOL 4.106**

Given that transformer rating 1kVA, 230V/100V, 1- $\phi$ , 50Hz, operated at 250 V, 50 Hz at high voltage winding and resistive load at low voltage



now equivalent circuit referred to high voltage side is as

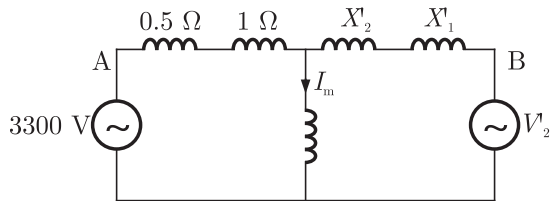

$$X'_2 = \left(\frac{99}{12}\right)^2 \times 0.012 = 0.8167$$

$$X'_1 = \left(\frac{99}{12}\right)^2 \times 0.01 = 0.68$$

$$V'_2 = \left(\frac{99}{12}\right) \times 400 = 3300 \text{ V}$$

now magnetizing current

$$I_m = \frac{3300}{0.5 + 1.0 + 500} + \frac{3300}{0.8167 + 0.68 + 500}$$

$$= 13.1605 \text{ Amp}$$

magnetizing ampere turns

$$A_T = 13.1605 \times 99 = 1302.84 \text{ Ampereturns}$$

**SOL 4.113\***

Equivalent circuit of induction motor referred to stator side

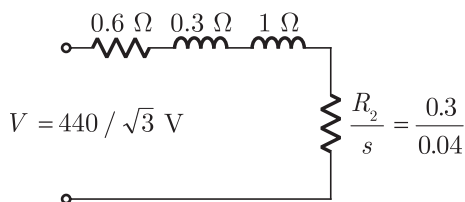

$$N_s = \frac{120f}{P} = \frac{120 \times 50}{6} = 1000 \text{ rpm}$$

$$\text{slip} = \frac{N_s - N_r}{N_s} = \frac{1000 - 960}{1000} = 0.04$$

$$\text{Current } I = \frac{V}{\sqrt{\left(R_s + \frac{R'_r}{S}\right)^2 + (X_s + X'_r)^2}}$$

$$= \frac{440}{\sqrt{3} \sqrt{\left(0.6 + \frac{0.3}{0.04}\right)^2 + (1 + 1)^2}} = 30.447 \text{ Amp}$$

$$\text{Torque } T_e = \frac{3}{\omega_s} I_2^2 \left(\frac{r}{s}\right)$$

**NOTES**

$$T_e = \frac{3 \times 60}{2\pi \times 1000} \times (30.447)^2 \times \frac{0.3}{0.04}$$

$$= 199.18 \text{ N-m}$$

If it will work as generator than slip will be negative

$$S = \frac{N_s - N_r}{N_s}$$

$$-0.4 = \frac{1000 - N_r}{1000}$$

$$N_r = 1040 \text{ rpm}$$

**SOL 4.114\***

Given

415 V, 2-Pole, 3- $\phi$ , 50 Hz, Y-connected synchronous motor

$$X_s = 2 \Omega \text{ per phase } I = 20 \text{ A at 4 PF}$$

Mechanical load is increased till  $I = 50 \text{ A}$

Than

- (a) Per phase open circuit voltage  $E_0 = ?$
- (b) Developed power = ?

In first case the UPF phasor diagram is being drawn as

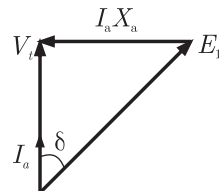

from phasor diagram

$$E_0^2 = V_t^2 + I_a^2 \times s^2$$

$$= \left(\frac{415}{\sqrt{3}}\right)^2 + 20^2 \times 2^2$$

$$= 242.91 \text{ V}$$

now  $I_a$  is increased than load angle and power factor angle is also increased as ( $E_0 = \text{constant}$ )

Than

$$(I_a \times X_s)^2 = E_0^2 + V_t^2 - 2E_0 V_t \cos \delta$$

$$(50 \times 2)^2 = (242.91)^2 + \left(\frac{415}{\sqrt{3}}\right)^2 - 2 \times \frac{242.91}{\sqrt{3}} \times 415 \cos \delta$$

$$\cos \delta = \frac{(242.91)^2 + (239.6)^2 - (100)^2}{2 \times 242.91 \times 239.6}$$

$$\cos \delta = 0.914 \Rightarrow \delta = 23.90^\circ$$

$$\text{Power } P_i = \frac{E_0 V_t \sin \delta}{X}$$

$$= \frac{242.91 \times 239.6}{2} \sin 23.9$$

$$= 11789.87$$

$$P_i = VI \cos \theta = 11789.87$$

$$239.6 \times 50 \cos \theta = 11789.87$$

$$\cos \theta = 9841$$

$$\begin{aligned} \text{Power developed} &= 3(P - I^2 R) \\ &= 3(11789.87 - 50^2 \times 2) \\ &= 35369.61 \text{ W} \end{aligned}$$

**SOL 4.115**

We know that in case of practical transformer with resistive load, the core flux is strictly constant with variation of load.

Hence (A) is correct option.

**SOL 4.116**

In synchronous machine it is known that

$$X_d > X'_d > X''_d$$

where  $X_d$  = steady state  $d$ -axis reactance

$X'_d$  = transient  $d$ -axis reactance

$X''_d$  = sub-transient  $d$ -axis reactance

Hence (A) is correct option.

**SOL 4.117**

50 Hz, balanced 3- $\phi$ , Y-connected supply is given to Y-load instantaneous phase-a of supply is  $V \cos \omega t$  and load current is  $I \cos(\omega t - \phi)$  then 3- $\phi$  instantaneous power = ?

$P$  = sum of individual power of all phases

$$= V_1 I_1 + V_2 I_2 + V_3 I_3$$

$$= V \cos \omega t [I \cos(\omega t - \phi)] + V \cos(\omega t - 120^\circ) I \cos(\omega t - \phi - 120^\circ)$$

$$+ V \cos(\omega t + 120^\circ) I \cos(\omega t + 120^\circ - \phi)$$

$$= \frac{VI}{2} [\cos(2\omega t - \phi) + \cos \phi + \cos(2\omega t - 240^\circ - \phi) + \cos \phi$$

$$+ \cos(2\omega t + 240^\circ - \phi + \cos \phi)]$$

$$\text{or } P = \frac{VI}{2} [\cos(2\omega t - \phi) + 3 \cos \phi + \cos(2\omega t - \phi) \cos 240^\circ$$

$$- \sin(2\omega t - \phi) \sin 240^\circ + \cos(2\omega t - \phi) \cos 240^\circ + \sin(2\omega t - \phi) \sin 240^\circ]$$

**NOTES**

**SOL 4.125\***

Given

Two identical Generator each of 100 MVA in parallel

$$P = 100 \text{ MW at, p.f.} = 0.8 \text{ lagging}$$

Equal load sharing at initial.

If  $I_{f1}$  = reduced by 5% and  $I_{f2}$  = increased by 5%

Then load sharing of generator = ?

$$X_d = X_a = 0.8 \text{ Pu}$$

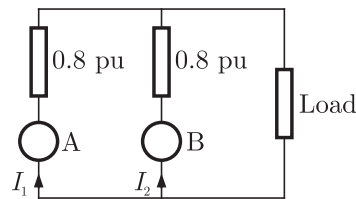

**Case I**

Load sharing of each generator equal i.e 50 MW at 0.8 p.f. lagging  
i.e 40 MW and 30 MVAR

$$V = I = 1 \text{ Pu}$$

Back emf of generators

$$\begin{aligned} E_{A1} = E_{B1} &= V + IX_d \sin \phi \\ &= 1 + 1 \times 0.8 \times 0.6 = 1.48 \text{ Pu} \end{aligned}$$

**Case II**

Now in first generator field in decreased by 5% i.e

$$E_{A2} = 0.95(E_{A1}) = 0.95 \times 1.48 = 1.40 \text{ Pu}$$

And in second generator field is increased by 5% i.e

$$E_{B2} = 1.05, \quad E_{B1} = 1.05 \times 1.48 = 1.554 \text{ Pu}$$

In this case  $I_1$  and  $I_2$  are being given by as

$$I_1 = \frac{1.4 - 1}{0.48} = 0.846 \text{ Pu}$$

$$I_2 = \frac{1.554 - 1}{0.48} = 1.154 \text{ Pu}$$

so

$$P_A = 1 \times 0.846 = 0.846 \text{ Pu}$$

$$P_B = 1 \times 1.154 = 1.154 \text{ Pu}$$

Load sharing in MW by generator 1 =  $0.846 \times 40 = 33.84 \text{ MW}$

by generator 2 =  $1.154 \times 40 = 46.16 \text{ MW}$

MVAR load sharing by generator 1 =  $0.846 \times 30 = 25.38 \text{ MVAR}$

MVAR load sharing by generator 2 =  $1.154 \times 30 = 34.62 \text{ MVAR}$

\*\*\*\*\*

# 5

---

## CHAPTER

# POWER SYSTEMS

---

YEAR 2010

ONE MARK

### MCQ 5.1

Power is transferred from system A to system B by an HVDC link as shown in the figure. If the voltage  $V_{AB}$  and  $V_{CD}$  are as indicated in figure, and  $I > 0$ , then

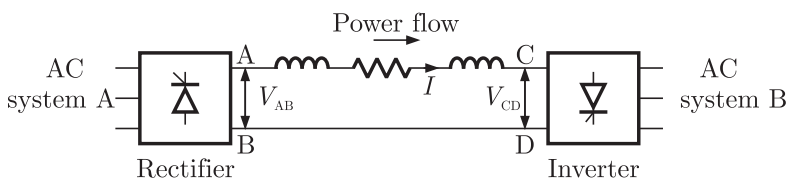

- (A)  $V_{AB} < 0, V_{CD} < 0, V_{AB} > V_{CD}$
- (B)  $V_{AB} > 0, V_{CD} > 0, V_{AB} < V_{CD}$
- (C)  $V_{AB} > 0, V_{CD} > 0, V_{AB} > V_{CD}$
- (D)  $V_{AB} > 0, V_{CD} < 0$

### MCQ 5.2

Consider a step voltage of magnitude 1 pu travelling along a lossless transmission line that terminates in a reactor. The voltage magnitude across the reactor at the instant travelling wave reaches the reactor is



**NOTES**

- (C) The magnitude of terminal voltage increases, and the field current increases
- (D) The magnitude of terminal voltage does not change and the field current decreases.

**MCQ 5.8**

Consider a three-phase, 50 Hz, 11 kV distribution system. Each of the conductors is suspended by an insulator string having two identical porcelain insulators. The self capacitance of the insulator is 5 times the shunt capacitance between the link and the ground, as shown in the figures. The voltages across the two insulators are

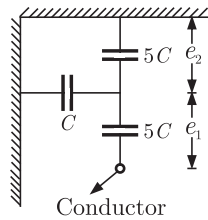

- (A)  $e_1 = 3.74 \text{ kV}, e_2 = 2.61 \text{ kV}$
- (B)  $e_1 = 3.46 \text{ kV}, e_2 = 2.89 \text{ kV}$
- (C)  $e_1 = 6.0 \text{ kV}, e_2 = 4.23 \text{ kV}$
- (D)  $e_1 = 5.5 \text{ kV}, e_2 = 5.5 \text{ kV}$

**MCQ 5.9**

Consider a three-core, three-phase, 50 Hz, 11 kV cable whose conductors are denoted as  $R, Y$  and  $B$  in the figure. The inter-phase capacitance( $C_1$ ) between each line conductor and the sheath is  $0.4 \mu\text{F}$ . The per-phase charging current is

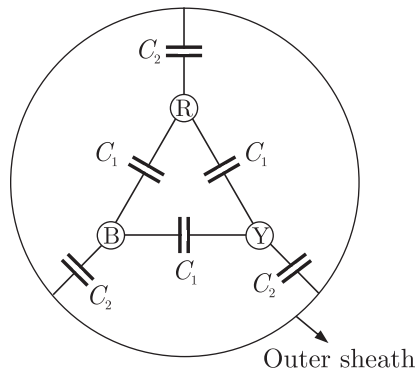

- (A) 2.0 A
- (B) 2.4 A
- (C) 2.7 A
- (D) 3.5 A

**NOTES**

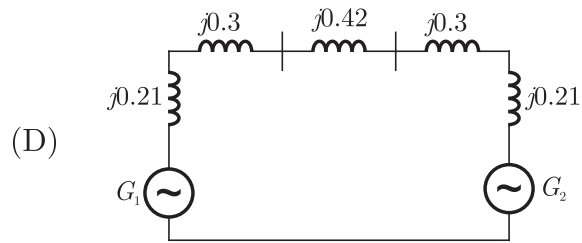
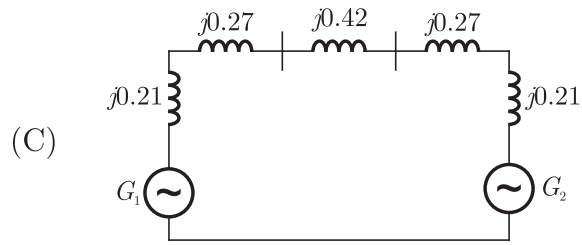

**YEAR 2009**

**ONE MARK**

**MCQ 5.11**

Out of the following plant categories

- (i) Nuclear
- (ii) Run-of-river
- (iii) Pump Storage
- (iv) Diesel

The base load power plant are

- (A) (i) and (ii)
- (B) (ii) and (iii)
- (C) (i), (ii) and (iv)
- (D) (i), (iii) and (iv)

**MCQ 5.12**

For a fixed value of complex power flow in a transmission line having a sending end voltage  $V$ , the real loss will be proportional to

- (A)  $V$
- (B)  $V^2$
- (C)  $\frac{1}{V^2}$
- (D)  $\frac{1}{V}$







**NOTES**

Shunt capacitance of the line can be neglect. If the has positive sequence impedance of  $15 \Omega$  and zero sequence impedance of  $48 \Omega$ , then the values of  $Z_s$  and  $Z_m$  will be

- (A)  $Z_s = 31.5 \Omega; Z_m = 16.5 \Omega$
- (B)  $Z_s = 26 \Omega; Z_m = 11 \Omega$
- (C)  $Z_s = 16.5 \Omega; Z_m = 31.5 \Omega$
- (D)  $Z_s = 11 \Omega; Z_m = 26 \Omega$

**YEAR 2008**

**TWO MARKS**

**MCQ 5.21**

Voltages phasors at the two terminals of a transmission line of length 70 km have a magnitude of 1.0 per unit but are 180 degree out of phase. Assuming that the maximum load current in the line is  $1/5^{\text{th}}$  of minimum 3-phase fault current. Which one of the following transmission line protection schemes will not pick up for this condition ?

- (A) Distance protection using ohm relay with zoen-1 set to 80% of the line impedance.
- (B) Directional over current protection set to pick up at 1.25 times the maximum load current
- (C) Pilot relaying system with directional comparison scheme
- (D) Pilot relaying system with segregated phase comparison scheme

**MCQ 5.22**

A loss less transmission line having Surge Impedance Loading (SIL) of 2280 MW is provided with a uniformly distributed series capacitive compensation of 30%. Then, SIL of the compensated transmission line will be

- (A) 1835 MW
- (B) 2280 MW
- (C) 2725 MW
- (D) 3257 MW

**MCQ 5.23**

A loss less power system has to serve a load of 250 MW. There are tow generation ( $G_1$  and  $G_2$ ) in the system with cost curves  $C_1$  and  $C_2$  respectively defined as follows ;





shown in the figure. Which of the following statements is true in the steady state :

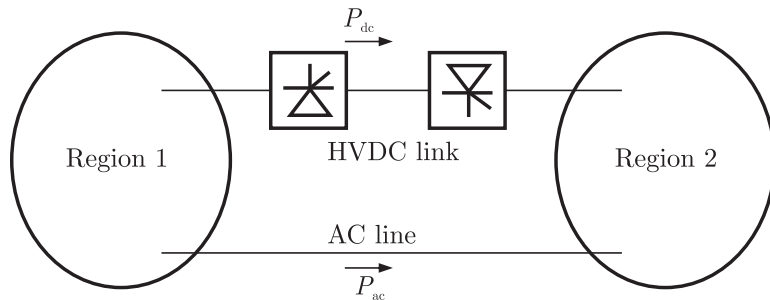

- (A) Both regions need not have the same frequency
- (B) The total power flow between the regions ( $P_{ac} + P_{dc}$ ) can be changed by controlled the HDVC converters alone
- (C) The power sharing between the ac line and the HVDC link can be changed by controlling the HDVC converters alone.
- (D) The directions of power flow in the HVDC link ( $P_{dc}$ ) cannot be reversed

**MCQ 5.32**

Considered a bundled conductor of an overhead line consisting of three identical sub-conductors placed at the corners of an equilateral triangle as shown in the figure. If we neglect the charges on the other phase conductor and ground, and assume that spacing between sub-conductors is much larger than their radius, the maximum electric field intensity is experienced at

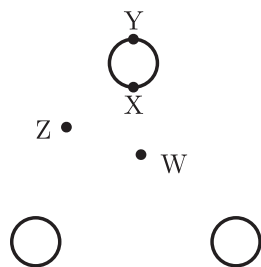

- (A) Point X
- (B) Point Y
- (C) Point Z
- (D) Point W

**NOTES**

**MCQ 5.33**

The figure below shows a three phase self-commutated voltage source converter connected to a power system. The converter's dc bus capacitor is marked as  $C$  in the figure. The circuit is initially operating in steady state with  $\delta = 0$  and the capacitor dc voltage is equal to  $V_{dc0}$ . You may neglect all losses and harmonics. What action should be taken to increase the capacitor dc voltage slowly to a new steady state value.

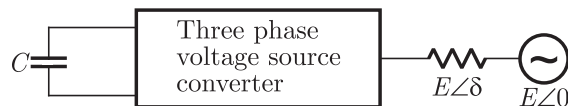

- (A) Make  $\delta$  positive and maintain it at a positive value
- (B) Make  $\delta$  positive and return it to its original value
- (C) Make  $\delta$  negative and maintain it at a negative value
- (D) Make  $\delta$  negative and return it to its original value

**MCQ 5.34**

The total reactance and total susceptance of a lossless overhead EHV line, operating at 50 Hz, are given by 0.045 pu and 1.2 pu respectively. If the velocity of wave propagation is  $3 \times 10^5$  km/s, then the approximate length of the line is

- (A) 122 km
- (B) 172 km
- (C) 222 km
- (D) 272 km

**MCQ 5.35**

Consider the protection system shown in the figure below. The circuit breakers numbered from 1 to 7 are of identical type. A single line to ground fault with zero fault impedance occurs at the midpoint of the line (at point F), but circuit breaker 4 fails to operate (“Stuck breaker”). If the relays are coordinated correctly, a valid sequence of circuit breaker operation is





bus voltage phasors so obtain are indicated on figure A.

These two isolated systems are now interconnected by a short transmission line as shown in figure B, and it is found that  $P_1 = P_2 = Q_1 = Q_2 = 0$ .

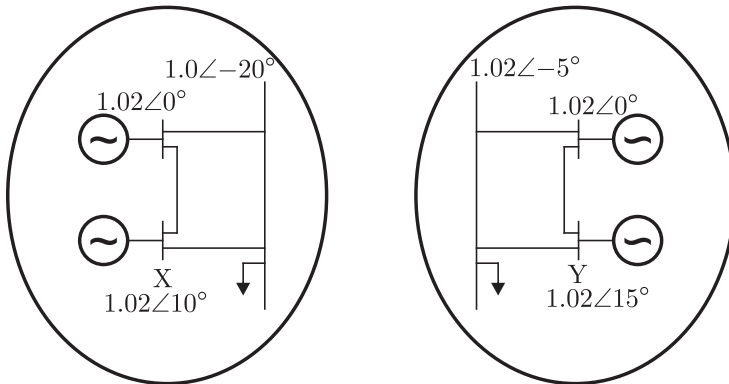

Fig A

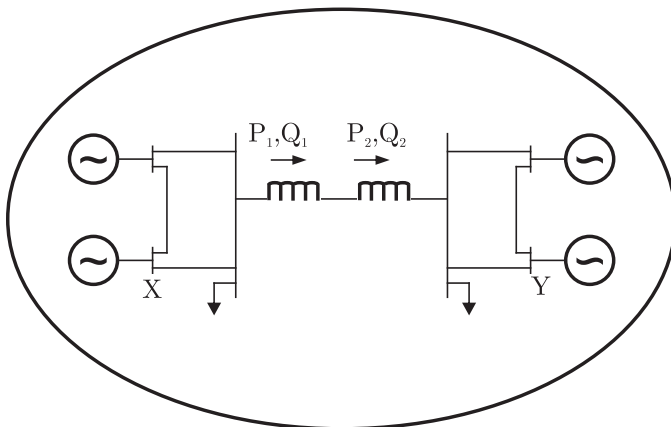

Fig B

The bus voltage phase angular difference between generator bus X and generator bus Y after interconnection is

- (A)  $10^\circ$
- (B)  $25^\circ$
- (C)  $-30^\circ$
- (D)  $30^\circ$

**MCQ 5.40**

A 230 V (Phase), 50 Hz, three-phase, 4-wire, system has a phase sequence ABC. A unity power-factor load of 4 kW is connected between phase A and neutral N. It is desired to achieve zero neutral

- (A) number of turns of restraining and operating coil
- (B) operating coil current and restraining coil current
- (C) fault current and operating coil current
- (D) fault current and restraining coil current

**MCQ 5.45**

An HVDC link consist of rectifier, inverter transmission line and other equipments. Which one of the following is true for this link ?

- (A) The transmission line produces/ supplies reactive power
- (B) The rectifier consumes reactive power and the inverter supplies reactive power from/ to the respective connected AC systems
- (C) Rectifier supplies reactive power and the inverted consumers reactive power to/ from the respective connected AC systems
- (D) Both the converters (rectifier and inverter) consume reactive power from the respective connected AC systems

**YEAR 2006**

**TWO MARKS**

**MCQ 5.46**

The  $A$ ,  $B$ ,  $C$ ,  $D$  constants of a 220 kV line are :

$$A = D = 0.94 \angle 1^\circ, B = 130 \angle 73^\circ, C = 0.001 \angle 90^\circ$$

If the sending end voltage of the line for a given load delivered at nominal voltage is 240 kV, the % voltage regulation of the line is

- (A) 5
- (B) 9
- (C) 16
- (D) 21

**MCQ 5.47**

A single phase transmission line and a telephone line are both symmetrically strung one below the other, in horizontal configurations, on a common tower, The shortest and longest distances between the phase and telephone conductors are 2.5 m and 3 m respectively.

The voltage (volt/km) induced in the telephone circuit, due to 50 Hz current of 100 amps in the power circuit is

- (A) 4.81
- (B) 3.56
- (C) 2.29
- (D) 1.27

**NOTES**

**MCQ 5.48**

Three identical star connected resistors of 1.0 pu are connected to an unbalanced 3-phase supply. The load neutral is isolated. The symmetrical components of the line voltages in pu. are:  $V_{ab_1} = X\angle\theta_1$ ,  $V_{ab_2} = Y\angle\theta_2$ . If all the pu calculations are with the respective base values, the phase to neutral sequence voltages are

- (A)  $V_{an_1} = X\angle(\theta_1 + 30^\circ)$ ,  $V_{an_2} = Y\angle(\theta_2 - 30^\circ)$
- (B)  $V_{an_1} = X\angle(\theta_1 - 30^\circ)$ ,  $V_{an_2} = Y\angle(\theta_2 + 30^\circ)$
- (C)  $V_{an_1} = \frac{1}{\sqrt{3}}X\angle(\theta_1 - 30^\circ)$ ,  $V_{an_2} = \frac{1}{\sqrt{3}}Y\angle(\theta_2 - 30^\circ)$
- (D)  $V_{an_1} = \frac{1}{\sqrt{3}}X\angle(\theta_1 - 60^\circ)$ ,  $V_{an_2} = \frac{1}{\sqrt{3}}Y\angle(\theta_2 - 60^\circ)$

**MCQ 5.49**

A generator is connected through a 20 MVA, 13.8/138 kV step down transformer, to a transmission line. At the receiving end of the line a load is supplied through a step down transformer of 10 MVA, 138/69 kV rating. A 0.72 pu. load, evaluated on load side transformer ratings as base values, is supplied from the above system. For system base values of 10 MVA and 69 kV in load circuit, the value of the load (in per unit) in generator will be

- (A) 36
- (B) 1.44
- (C) 0.72
- (D) 0.18

**MCQ 5.50**

The Gauss Seidel load flow method has following disadvantages.

Tick the incorrect statement.

- (A) Unreliable convergence
- (B) Slow convergence
- (C) Choice of slack bus affects convergence
- (D) A good initial guess for voltages is essential for convergence

**Data for Q. 51 and Q.52 are given below. Solve the problems and choose the correct answers.**

A generator feeds power to an infinite bus through a double circuit transmission line. A 3-phase fault occurs at the middle point of one of the lines. The infinite bus voltage is 1 pu, the transient internal voltage

**MCQ 5.59**

High Voltage DC (HVDC) transmission is mainly used for

- (A) bulk power transmission over very long distances
- (C) inter-connecting two systems with same nominal frequency
- (C) eliminating reactive power requirement in the operation
- (D) minimizing harmonics at the converter stations

**YEAR 2005**

**TWO MARKS**

**MCQ 5.60**

The parameters of a transposed overhead transmission line are given as :

Self reactance  $X_s = 0.4\Omega/\text{km}$  and Mutual reactance  $X_m = 0.1\Omega/\text{km}$   
 The positive sequence reactance  $X_1$  and zero sequence reactance  $X_0$ , respectively in  $\Omega/\text{km}$  are

- (A) 0.3, 0.2
- (B) 0.5, 0.2
- (C) 0.5, 0.6
- (D) 0.3, 0.6

**MCQ 5.61**

At an industrial sub-station with a 4 MW load, a capacitor of 2 MVAR is installed to maintain the load power factor at 0.97 lagging. If the capacitor goes out of service, the load power factor becomes

- (A) 0.85
- (B) 1.00
- (C) 0.80 lag
- (D) 0.90 lag

**MCQ 5.62**

The network shown in the given figure has impedances in p.u. as indicated. The diagonal element  $Y_{22}$  of the bus admittance matrix  $Y_{BUS}$  of the network is

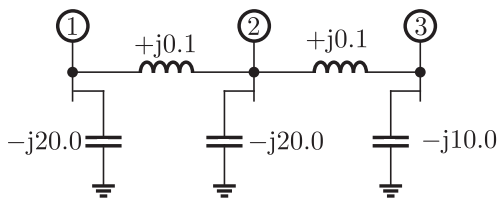

- (A)  $-j19.8$
- (B)  $+j20.0$
- (C)  $+j0.2$
- (D)  $-j19.95$



**NOTES**

**MCQ 5.69**

The rated voltage of a 3-phase power system is given as

- (A) rms phase voltage
- (B) peak phase voltage
- (C) rms line to line voltage
- (D) peak line to line voltage

**MCQ 5.70**

The phase sequences of the 3-phase system shown in figure is

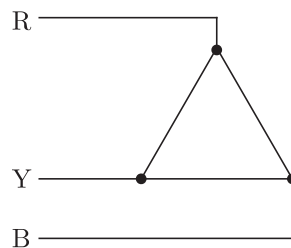

- (A) RYB
- (B) RBY
- (C) BRY
- (D) YBR

**MCQ 5.71**

In the thermal power plants, the pressure in the working fluid cycle is developed by

- (A) condenser
- (B) super heater
- (C) feed water pump
- (D) turbine

**MCQ 5.72**

For harnessing low variable waterheads, the suitable hydraulic turbine with high percentage of reaction and runner adjustable vanes is

- (A) Kaplan
- (B) Francis
- (C) Pelton
- (D) Impeller

**MCQ 5.73**

The transmission line distance protection relay having the property of being inherently directional is

- (A) impedance relay
- (B) MHO relay
- (C) OHM relay
- (D) reactance relay

**NOTES**

**MCQ 5.78**

A new generator having  $E_g = 1.4\angle 30^\circ$  pu. [equivalent to  $(1.212 + j0.70)$  pu] and synchronous reactance ' $X_S$ ' of 1.0 pu on the system base, is to be connected to a bus having voltage  $V_t$ , in the existing power system. This existing power system can be represented by Thevenin's voltage  $E_{th} = 0.9\angle 0^\circ$  pu in series with Thevenin's impedance  $Z_{th} = 0.25\angle 90^\circ$  pu. The magnitude of the bus voltage  $V_t$  of the system in pu will be

- (A) 0.990 (B) 0.973  
(C) 0.963 (D) 0.900

**MCQ 5.79**

A 3-phase generator rated at 110 MVA, 11 kV is connected through circuit breakers to a transformer. The generator is having direct axis sub-transient reactance  $X''_d = 19\%$ , transient reactance  $X'_d = 26\%$  and synchronous reactance  $= 130\%$ . The generator is operating at no load and rated voltage when a three phase short circuit fault occurs between the breakers and the transformer. The magnitude of initial symmetrical rms current in the breakers will be

- (A) 4.44 kA (B) 22.20 kA  
(C) 30.39 kA (D) 38.45 kA

**MCQ 5.80**

A 3-phase transmission line supplies  $\Delta$ -connected load  $Z$ . The conductor 'c' of the line develops an open circuit fault as shown in figure. The currents in the lines are as shown on the diagram. The +ve sequence current component in line 'a' will be

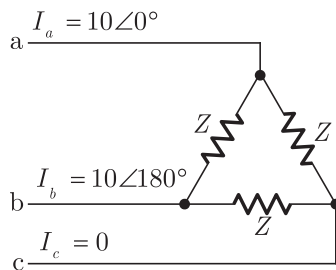

- (A)  $5.78\angle -30^\circ$  (B)  $5.78\angle 90^\circ$   
(C)  $6.33\angle 90^\circ$  (D)  $10.00\angle -30^\circ$

**MCQ 5.81**

A 500 MVA, 50 Hz, 3-phase turbo-generator produces power at 22 kV. Generator is Y-connected and its neutral is solidly grounded. Its sequence reactances are  $X_1 = X_2 = 0.15$  pu and  $X_0 = 0.05$  pu. It is operating at rated voltage and disconnected from the rest of the system (no load). The magnitude of the sub-transient line current for single line to ground fault at the generator terminal in pu will be

- (A) 2.851 (B) 3.333  
(C) 6.667 (D) 8.553

**MCQ 5.82**

A 50 Hz, 4-pole, 500 MVA, 22 kV turbo-generator is delivering rated megavolt-amperes at 0.8 power factor. Suddenly a fault occurs reducing in electric power output by 40%. Neglect losses and assume constant power input to the shaft. The accelerating torque in the generator in MNm at the time of fault will be

- (A) 1.528 (B) 1.018  
(C) 0.848 (D) 0.509

**MCQ 5.83**

A hydraulic turbine having rated speed of 250 rpm is connected to a synchronous generator. In order to produce power at 50 Hz, the number of poles required in the generator are

- (A) 6 (B) 12  
(C) 16 (D) 24

**YEAR 2003**

**ONE MARK**

**MCQ 5.84**

Bundled conductors are mainly used in high voltage overhead transmission lines to

- (A) reduces transmission line losses  
(B) increase mechanical strength of the line  
(C) reduce corona  
(D) reduce sag



- (B) energizing of the trip circuit and the arc extinction on an opening operation
- (C) initiation of short circuit and the parting of primary arc contacts
- (D) energizing of the trip circuit and the parting of primary arc contacts

**YEAR 2003**

**TWO MARKS**

**MCQ 5.89**

The  $ABCD$  parameters of a 3-phase overhead transmission line are  $A = D = 0.9 \angle 0^\circ$ ,  $B = 200 \angle 90^\circ \Omega$  and  $C = 0.95 \times 10^{-3} \angle 90^\circ \text{ S}$ . At no-load condition a shunt inductive reactor is connected at the receiving end of the line to limit the receiving-end voltage to be equal to the sending-end voltage. The ohmic value of the reactor is

- (A)  $\infty \Omega$
- (B)  $2000 \Omega$
- (C)  $105.26 \Omega$
- (D)  $1052.6 \Omega$

**MCQ 5.90**

A surge of 20 kV magnitude travels along a lossless cable towards its junction with two identical lossless overhead transmission lines. The inductance and the capacitance of the cable are 0.4 mH and  $0.5 \mu\text{F}$  per km. The inductance and capacitance of the overhead transmission lines are 1.5 mH and  $0.015 \mu\text{F}$  per km. The magnitude of the voltage at the junction due to surge is

- (A) 36.72 kV
- (B) 18.36 kV
- (C) 6.07 kV
- (D) 33.93 kV

**MCQ 5.91**

A dc distribution system is shown in figure with load current as marked. The two ends of the feeder are fed by voltage sources such that  $V_P - V_Q = 3 \text{ V}$ . The value of the voltage  $V_P$  for a minimum voltage of 220 V at any point along the feeder is



**NOTES**

**List-I**

- P. Distance relay
- Q. Under frequency relay
- R. Differential relay
- S. Buchholz relay

**List-II**

- 1. Transformers
- 2. Turbines
- 3. Busbars
- 4. Shunt capacitors
- 5. Alternators
- 6. Transmission lines

**Codes:**

	P	Q	R	S
(A)	6	5	3	1
(B)	4	3	2	1
(C)	5	2	1	6
(D)	6	4	5	3

**MCQ 5.97**

A generator delivers power of 1.0 p.u. to an infinite bus through a purely reactive network. The maximum power that could be delivered by the generator is 2.0 p.u. A three-phase fault occurs at the terminals of the generator which reduces the generator output to zero. The fault is cleared after  $t_c$  second. The original network is then restored. The maximum swing of the rotor angle is found to be  $\delta_{\max} = 110$  electrical degree. Then the rotor angle in electrical degrees at  $t = t_c$  is

- (A) 55
- (B) 70
- (C) 69.14
- (D) 72.4

**MCQ 5.98**

A three-phase alternator generating unbalanced voltages is connected to an unbalanced load through a 3-phase transmission line as shown in figure. The neutral of the alternator and the star point of the load are solidly grounded. The phase voltages of the alternator are  $E_a = 10\angle 0^\circ \text{ V}$ ,  $E_b = 10\angle -90^\circ \text{ V}$ ,  $E_c = 10\angle 120^\circ \text{ V}$ . The positive-sequence component of the load current is

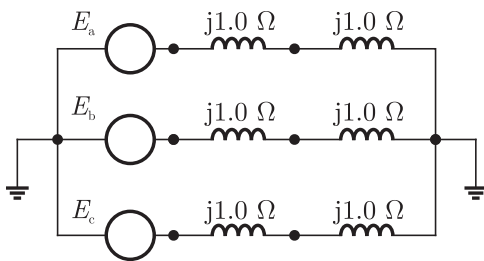

- (A)  $1.310 \angle -107^\circ$  A                      (B)  $0.332 \angle -120^\circ$  A  
 (C)  $0.996 \angle -120^\circ$  A                      (D)  $3.510 \angle -81^\circ$  A

**MCQ 5.99**

A balanced delta connected load of  $(8 + j6) \Omega$  per phase is connected to a 400 V, 50 Hz, 3-phase supply lines. If the input power factor is to be improved to 0.9 by connecting a bank of star connected capacitor the required kVAR of the of the bank is

- (A) 42.7    (B) 10.2  
 (C) 28.8    (D) 38.4

**YEAR 2002**

**ONE MARK**

**MCQ 5.100**

Consider a power system with three identical generators. The transmission losses are negligible. One generator(G1) has a speed governor which maintains its speed constant at the rated value, while the other generators(G2 and G3) have governors with a droop of 5%. If the load of the system is increased, then in steady state.

- (A) generation of G2 and G3 is increased equally while generation of G1 is unchanged.  
 (B) generation of G1 alone is increased while generation of G2 and G3 is unchanged.  
 (C) generation of G1, G2 and G3 is increased equally.  
 (D) generally of G1, G2 and G3 is increased in the ratio 0.5 : 0.25 : 0.25.

**NOTES**

on this system. While entering the network data, the tie-line data (connectivity and parameters) is inadvertently left out. If the load flow program is run with this incomplete data

- (A) The load-flow will converge only if the slack bus is specified in area 1
- (B) The load-flow will converge only if the slack bus is specified in area 2
- (C) The load-flow will converge if the slack bus is specified in either area 1 or area 2
- (D) The load-flow will not converge if only one slack is specified.

**MCQ 5.104**

A transmission line has a total series reactance of 0.2 pu. Reactive power compensation is applied at the midpoint of the line and it is controlled such that the midpoint voltage of the transmission line is always maintained at 0.98 pu. If voltage at both ends of the line are maintained at 1.0 pu, then the steady state power transfer limit of the transmission line is

- (A) 9.8 pu
- (B) 4.9 pu
- (C) 19.6 pu
- (D) 5 pu

**MCQ 5.105**

A generator is connected to a transformer which feeds another transformer through a short feeder (see figure). The zero sequence impedance values expressed in pu on a common base and are indicated in figure. The Thevenin equivalent zero sequence impedance at point B is

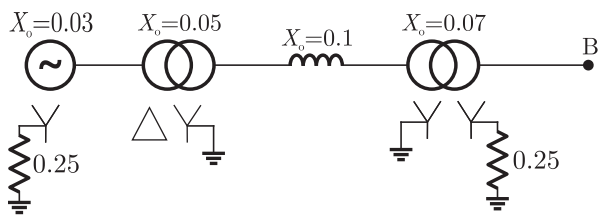

- (A)  $0.8 + j0.6$
- (B)  $0.75 + j0.22$
- (C)  $0.75 + j0.25$
- (D)  $1.5 + j0.25$

**NOTES**

**MCQ 5.106\***

A long lossless transmission line has a unity power factor (UPF) load at the receiving end and an ac voltage source at the sending end. The parameters of the transmission line are as follows :

Characteristic impedance  $Z_c = 400 \Omega$ , propagation constant  $\beta = 1.2 \times 10^{-3}$  rad/km, and the length  $l = 100$  km. The equation relating sending and receiving end questions is

$$V_s = V_r \cos(\beta l) + jZ_c \sin(\beta l) I_R$$

Compute the maximum power that can be transferred to the UPF load at the receiving end if  $|V_s| = 230$  kV

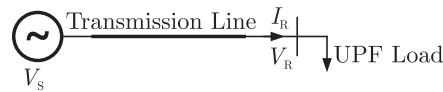

**MCQ 5.107\***

Two transposed 3-phase lines run parallel to each other. The equation describing the voltage drop in both lines is given below.

$$\begin{bmatrix} \Delta V_{a1} \\ \Delta V_{b1} \\ \Delta V_{c1} \\ \Delta V_{a2} \\ \Delta V_{b2} \\ \Delta V_{c2} \end{bmatrix} = j \begin{bmatrix} 0.15 & 0.05 & 0.05 & 0.04 & 0.04 & 0.04 \\ 0.05 & 0.15 & 0.05 & 0.04 & 0.04 & 0.04 \\ 0.05 & 0.05 & 0.15 & 0.04 & 0.04 & 0.04 \\ 0.04 & 0.04 & 0.04 & 0.15 & 0.05 & 0.05 \\ 0.04 & 0.04 & 0.04 & 0.05 & 0.15 & 0.05 \\ 0.04 & 0.04 & 0.04 & 0.05 & 0.05 & 0.15 \end{bmatrix} \begin{bmatrix} I_{a1} \\ I_{b1} \\ I_{c1} \\ I_{a2} \\ I_{b2} \\ I_{c2} \end{bmatrix}$$

Compute the self and mutual zero sequence impedance of this system i.e. compute  $Z_{011}, Z_{012}, Z_{021}, Z_{022}$  in the following equations.

$$\Delta V_{01} = Z_{011} I_{01} + Z_{012} I_{02}$$

$$\Delta V_{02} = Z_{021} I_{01} + Z_{022} I_{02}$$

Where  $\Delta V_{01}, \Delta V_{02}, I_{01}, I_{02}$  are the zero sequence voltage drops and currents for the two lines respectively.

**MCQ 5.108\***

A synchronous generator is to be connected to an infinite bus through a transmission line of reactance  $X = 0.2$  pu, as shown in figure. The generator data is as follows :

$x' = 0.1$  pu,  $E' = 1.0$  pu,  $H = 5$  MJ/MVA, mechanical power  $P_m = 0.0$  pu,  $\omega_B = 2\pi \times 50$  rad/s. All quantities are expressed on a

**MCQ 5.115**

Consider the model shown in figure of a transmission line with a series capacitor at its mid-point. The maximum voltage on the line is at the location

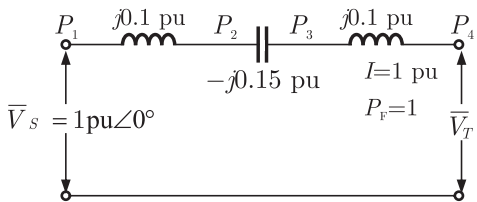

- (A)  $P_1$  (B)  $P_2$   
(C)  $P_3$  (D)  $P_4$

**MCQ 5.116**

A power system has two synchronous generators. The Governor-turbine characteristics corresponding to the generators are

$$P_1 = 50(50 - f), P_2 = 100(51 - f)$$

where  $f$  denotes the system frequency in Hz, and  $P_1$  and  $P_2$  are, respectively, the power outputs (in MW) of turbines 1 and 2. Assuming the generators and transmission network to be lossless, the system frequency for a total load of 400 MW is

- (A) 47.5 Hz (B) 48.0 Hz  
(C) 48.5 Hz (D) 49.0 Hz

**MCQ 5.117\***

A 132 kV transmission line AB is connected to a cable BC. The characteristic impedances of the overhead line and the cable are 400  $\Omega$  and 80  $\Omega$  respectively. Assume that these are purely resistive. Assume that these are purely resistive. A 250 kV switching surge travels from A to B.

- (a) Calculate the value of this voltage surge when it first reaches C  
(b) Calculate the value of the reflected component of this surge when the first reflection reaches A.  
(c) Calculate the surge current in the cable BC.

$$100 \text{ MW} \leq P_{G1} \leq 650 \text{ MW}$$

$$50 \text{ MW} \leq P_{G2} \leq 500 \text{ MW}$$

A load demand of 600 MW is supplied by the generators in an optimal manner. Neglecting losses in the transmission network, determine the optimal generation of each generator.

\*\*\*\*\*

**NOTES**



## SOLUTION

### SOL 5.1

Given that,

$$I > 0$$

$\therefore V_{AB} > 0$  since it is Rectifier O/P

$V_{CD} > 0$  since it is Inverter I/P

$\therefore I > 0$  so  $V_{AB} > V_{CD}$ , Then current will flow in given direction.

Hence (C) is correct option.

### SOL 5.2

Given step voltage travel along lossless transmission line.

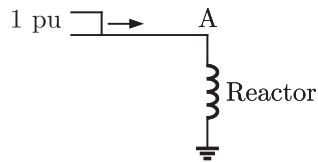

$\therefore$  Voltage wave terminated at reactor as.

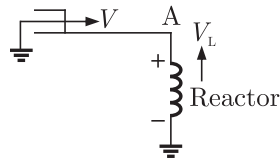

By Applying KVL

$$V + V_L = 0$$

$$V_L = -V$$

$$V_L = -1 \text{ pu}$$

Hence (A) is correct option.

### SOL 5.3

Given two buses connected by an Impedance of  $(0 + j5)\Omega$

The Bus '1' voltage is  $100 \angle 30^\circ$  V and Bus '2' voltage is  $100 \angle 0^\circ$  V

We have to calculate real and reactive power supply by bus '1'

$$e_1 = \frac{\frac{11}{\sqrt{3}}(6C)}{6C + 5C} = \frac{11}{\sqrt{3}} \times \frac{6}{11} = 3.46 \text{ kV}$$

$$e_2 = \frac{11}{\sqrt{3}} \times \frac{5}{11} \\ = 2.89 \text{ kV}$$

Hence (B) is correct option.

**SOL 5.9**

Given

3- $\phi$ , 50 Hz, 11 kV cable

$$C_1 = 0.2 \mu\text{F}$$

$$C_2 = 0.4 \mu\text{F}$$

Charging current  $I_C$  per phase = ?

$$\text{Capacitance Per Phase } C = 3C_1 + C_2$$

$$C = 3 \times 0.2 + 0.4 = 1 \mu\text{F}$$

$$\omega = 2\pi f = 314$$

$$\text{Charging current } I_C = \frac{V}{X_C} = V(\omega C)$$

$$= \frac{11 \times 10^3}{\sqrt{3}} \times 314 \times 1 \times 10^{-6}$$

$$= 2 \text{ Amp}$$

Hence (A) is correct option.

**SOL 5.10**

Generator  $G_1$  and  $G_2$

$$X_{G1} = X_{G2} = X_{\text{old}} \times \frac{\text{New MVA}}{\text{Old MVA}} \times \left( \frac{\text{Old kV}}{\text{New kV}} \right)^2$$

$$= j0.9 \times \frac{200}{100} \times \left( \frac{25}{25} \right)^2 = j0.18$$

$$\text{Same as } X_{T1} = j0.12 \times \frac{200}{90} \times \left( \frac{25}{25} \right)^2 = j0.27$$

$$X_{T2} = j0.12 \times \frac{200}{90} \times \left( \frac{25}{25} \right)^2 = j0.27$$

$$X_{\text{Line}} = 150 \times \frac{220}{(220)^2} = j0.62$$

The Impedance diagram is being given by as

**NOTES**

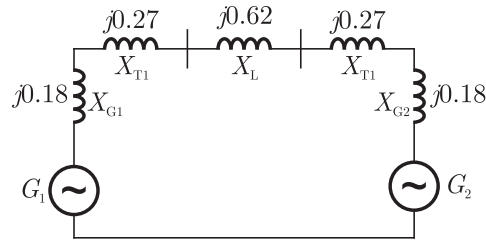

Hence (B) is correct option.

**SOL 5.11**

**SOL 5.12**

We know complex power

$$\begin{aligned} S &= P + jQ = VI(\cos \phi + j\sin \phi) \\ &= VIe^{j\phi} \\ I &= \frac{S}{Ve^{j\phi}} \end{aligned}$$

$\therefore$  Real Power loss =  $I^2 R$

$$P_L = \left( \frac{S}{Ve^{j\phi}} \right)^2 R = \frac{S^2 R}{e^{j2\phi}} \times \frac{1}{V^2} \quad \therefore \frac{S^2 R}{e^{j2\phi}} = \text{Constant}$$

So  $P_L \propto \frac{1}{V^2}$

Hence (C) is correct option.

**SOL 5.13**

$Y_{\text{Bus}}$  matrix of Y-Bus system are given as

$$Y_{\text{Bus}} = j \begin{bmatrix} -5 & 2 & 2.5 & 0 \\ 2 & -10 & 2.5 & 0 \\ 2.5 & 2.5 & -9 & 4 \\ 0 & 4 & 4 & -8 \end{bmatrix}$$

We have to find out the buses having shunt element

We know  $Y_{\text{Bus}} = \begin{bmatrix} y_{11} & y_{12} & y_{13} & y_{14} \\ y_{21} & y_{22} & y_{23} & y_{24} \\ y_{31} & y_{32} & y_{33} & y_{34} \\ y_{41} & y_{42} & y_{43} & y_{44} \end{bmatrix}$

Here

$$\begin{aligned} y_{11} &= y_{10} + y_{12} + y_{13} + y_{14} = -5j \\ y_{22} &= y_{20} + y_{21} + y_{23} + y_{24} = -10j \end{aligned}$$

$$y_{33} = y_{30} + y_{31} + y_{32} + y_{34} = -9j$$

$$y_{44} = y_{40} + y_{41} + y_{42} + y_{43} = -8j$$

$$y_{12} = y_{21} = -y_{12} = 2j$$

$$y_{13} = y_{31} = -y_{13} = 2.5j$$

$$y_{14} = y_{41} = -y_{14} = 0j$$

$$y_{23} = y_{32} = -y_{23} = 2.5j$$

$$y_{24} = y_{42} = -y_{24} = 4j$$

So

$$y_{10} = y_{11} - y_{12} - y_{13} - y_{14} = -5j + 2j + 2.5j + 0j = -0.5j$$

$$y_{20} = y_{22} - y_{12} - y_{23} - y_{24} = -10j + 2j + 2.5j + 4j = -1.5j$$

$$y_{30} = y_{33} - y_{31} - y_{32} - y_{34} = -9j + 2.5j + 2.5j + 4j = 0$$

$$y_{40} = y_{44} - y_{41} - y_{42} - y_{43} = -8j - 0 + 4j + 4j = 0$$

Admittance diagram is being made by as

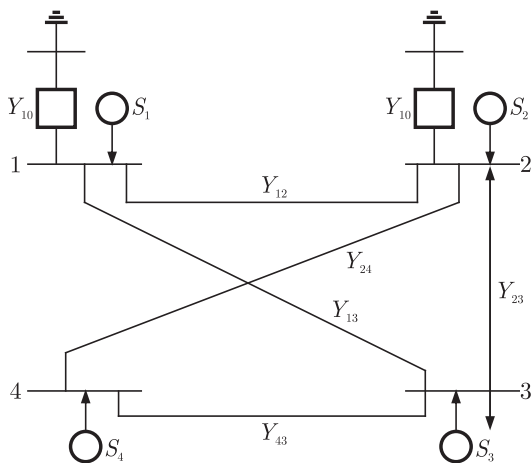

From figure. it is cleared that branch (1) & (2) behaves like shunt element.

Hence (C) is correct option.

**SOL 5.14**

We know that

- Shunt Capacitors are used for improving power factor.
- Series Reactors are used to reduce the current ripples.
- For increasing the power flow in line we use series capacitor.
- Shunt reactors are used to reduce the Ferranti effect.

Hence (B) is correct option.

**NOTES**

**SOL 5.15**

We know that for different type of transmission line different type of distance relays are used which are as follows.

Short Transmission line -Ohm reactance used

Medium Transmission Line -Reactance relay is used

Long Transmission line -Mho relay is used

Hence (C) is correct option.

**SOL 5.16**

Given that three generators are feeding a load of 100 MW. For increased load power demand, Generator having better regulation share More power, so Generator -1 will share More power than Generator -2.

Hence (C) is correct option.

**SOL 5.17**

Given Synchronous generator of 500 MW, 21 kV, 50 Hz, 3- $\phi$ , 2-pole  
P.F = 0.9, Moment of inertia  $M = 27.5 \times 10^3 \text{ kg-m}^2$

Inertia constant  $H = ?$

Generator rating in MVA  $G = \frac{P}{\cos \phi} = \frac{500 \text{ MW}}{0.9} = 555.56 \text{ MVA}$

$$N = \frac{120 \times f}{\text{pole}} = \frac{120 \times 50}{2} = 3000 \text{ rpm}$$

$$\begin{aligned} \text{Stored K.E} &= \frac{1}{2} M \omega^2 = \frac{1}{2} M \left( \frac{2\pi N}{60} \right)^2 \\ &= \frac{1}{2} \times 27.5 \times 10^3 \times \left( \frac{2\pi \times 3000}{60} \right)^2 \text{ MJ} \\ &= 1357.07 \text{ MJ} \end{aligned}$$

$$\text{Inertia constant } (H) = \frac{\text{Stored K.E}}{\text{Rating of Generator (MVA)}}$$

$$\begin{aligned} H &= \frac{1357.07}{555.56} \\ &= 2.44 \text{ sec} \end{aligned}$$

Hence (A) is correct option.

**SOL 5.18**

Given for X to F section of phase 'a'

$V_a$ -Phase voltage and  $I_a$ -phase current.

Impedance measured by ground distance,

**NOTES**

**SOL 5.23**

Given  $P_{G1} + P_{G2} = 250 \text{ MW}$  ... (1)

and 
$$\left. \begin{aligned} C_1(P_{G1}) &= P_{G1} + 0.055P_{G1}^2 \\ C_2(P_{G2}) &= 3P_{G2} + 0.03P_{G2}^2 \end{aligned} \right\} \dots (2)$$

from equation (2)

$$\frac{dC_1}{dP_{G1}} = 1 + 0.11P_{G1} \dots (3a)$$

and 
$$\frac{dC_2}{dP_{G2}} = 3 + 0.06P_{G2} \dots (3b)$$

Since the system is loss-less

Therefore 
$$\frac{dC_1}{dP_{G1}} = \frac{dC_2}{dP_{G2}}$$

So from equations (3a) and (3b)

We have  $0.11P_{G1} - 0.06P_{G2} = 2$  ... (4)

Now solving equation (1) and (4), we get

$$P_{G1} = 100 \text{ MW}$$

$$P_{G2} = 150 \text{ MW}$$

Hence (C) is correct option.

**SOL 5.24**

After connecting both the generators in parallel and scheduled to supply 0.5 Pu of power results the increase in the current.

∴ Critical clearing time will reduced from 0.28 s but will not be less than 0.14 s for transient stability purpose.

Hence (B) is correct option.

**SOL 5.25**

Given that the each section has equal impedance.

Let it be  $R$  or  $Z$ , then by using the formula

$$\text{line losses} = \sum I^2 R$$

$$\begin{aligned} \text{On removing } (e_1); \text{ losses} &= (1)^2 R + (1 + 2)^2 R + (1 + 2 + 5)^2 R \\ &= R + 9R + 64R = 74R \end{aligned}$$

Similarly,

$$\begin{aligned} \text{On removing } e_2; \text{ losses} &= 5^2 R + (5 + 2)^2 R + (5 + 2 + 1)^2 R \\ &= 138R \end{aligned}$$

$$\begin{aligned} \text{lossess on removing } e_3 &= (1)^2 R + (2)^2 R + (5 + 2)^2 R \\ &= 1R + 4R + 49R \\ &= 54R \end{aligned}$$

$$\begin{aligned} \text{on removing } e_4 \text{ lossless} &= (2)^2 R + (2 + 1)^2 R + 5^2 R \\ &= 4R + 9R + 25R \\ &= 38R \end{aligned}$$

So, minimum losses are gained by removing  $e_4$  branch.  
Hence (D) is correct option.

**SOL 5.26**

Given

$$V(t) = V_m \cos(\omega t)$$

For symmetrical 3- $\phi$  fault, current after the fault

$$i(t) = A e^{-(R/L)t} + \frac{\sqrt{2} V_m}{|Z|} \cos(\omega t - \alpha)$$

At the instant of fault i.e  $t = t_0$ , the total current  $i(t) = 0$

$$\therefore 0 = A e^{-(R/L)t_0} + \frac{\sqrt{2} V_m}{|Z|} \cos(\omega t_0 - \alpha)$$

$$A e^{-(R/L)t_0} = -\frac{\sqrt{2} V_m}{|Z|} \cos(\omega t_0 - \alpha)$$

Maximum value of the dc offset current

$$A e^{-(R/L)t_0} = -\frac{\sqrt{2} V_m}{|Z|} \cos(\omega t_0 - \alpha)$$

For this to be negative max.

$$(\omega t_0 - \alpha) = 0$$

$$\text{or } t_0 = \frac{\alpha}{\omega} \quad \dots(1)$$

$$\text{and } Z = 0.004 + j0.04$$

$$Z = |Z| \angle \alpha = 0.0401995 \angle 84.29^\circ$$

$$\therefore \alpha = 84.29^\circ \text{ or } 1.471 \text{ rad.}$$

From equation (1)

$$t_0 = \frac{1.471}{(2\pi \times 50)} = 0.00468 \text{ sec}$$

$$t_0 = 4.682 \text{ ms}$$

Hence (A) is correct option.

**SOL 5.27**

Since the fault 'F' is at mid point of the system, therefore impedance seen is same from both sides.

**NOTES**

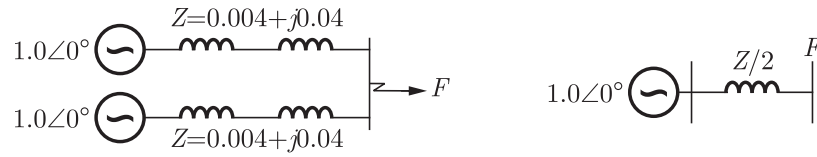

$$\frac{Z}{2} = 0.0201 \angle 84.29^\circ$$

$$Z_1(\text{Positive sequence}) = \frac{Z}{2} = 0.0201 \angle 84.29^\circ$$

also  $Z_1 = Z_2 = Z_0$  (for 3- $\phi$  fault)

$$\therefore I_f(\text{pu}) = \frac{1 \angle 0^\circ}{Z_1} = \frac{1 \angle 0^\circ}{0.0201 \angle 84.29^\circ}$$

So magnitude  $|I_f|_{(\text{p.u.})} = 49.8$

$$\begin{aligned} \therefore \text{Fault current } I_f &= 49.8 \times \frac{100}{\sqrt{3} \times 400} \\ &= 7.18 \text{ kA} \end{aligned}$$

Hence (C) is correct option.

**SOL 5.28**

If fault is LG in phase 'a'

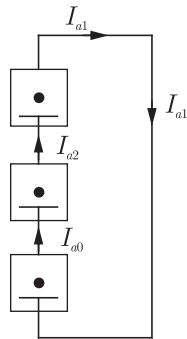

$$Z_1 = \frac{Z}{2} = 0.0201 \angle 84.29^\circ$$

$$Z_2 = Z_1 = 0.0201 \angle 84.29^\circ$$

and  $Z_0 = 3Z_1 = 0.0603 \angle 84.29^\circ$

Then

$$I_a/3 = I_{a1} = I_{a2} = I_{a0}$$

$$\therefore I_{a1}(\text{pu}) = \frac{1.0 \angle 0^\circ}{Z_1 + Z_2 + Z_0}$$



and  $|I_{a1}| = \frac{1.0}{(0.0201 + 0.0201 + 0.0603)} = 9.95 \text{ pu}$

Fault Current  $I_f = I_a = 3I_{a1} = 29.85 \text{ pu}$

So Fault current  $I_f = 29.85 \times \frac{100}{\sqrt{3} \times 400}$   
 $= 4.97 \text{ kA}$

Hence (A) is correct option.

**SOL 5.29**

$\therefore$  Equal Phase shift of point A & B with respect to source from both bus paths.

So the type of transformer Y-Y with angle  $0^\circ$ .

Hence (A) is correct option.

**SOL 5.30**

Given incremental cost curve

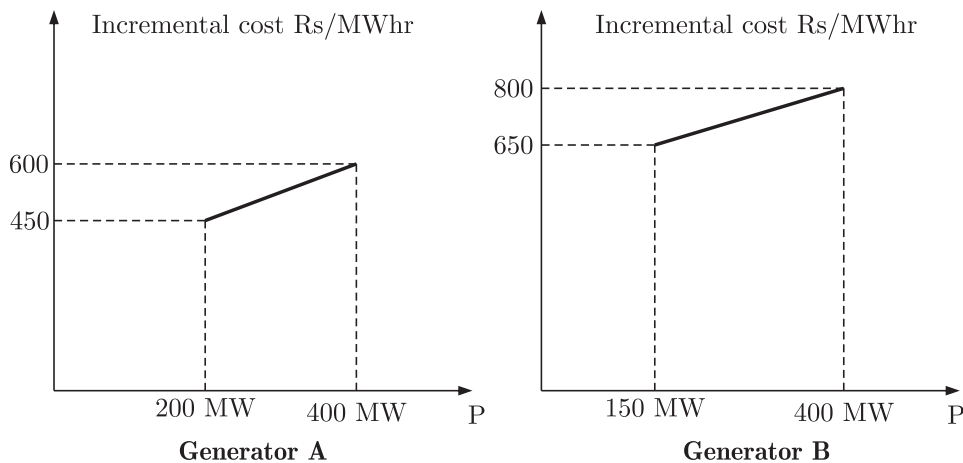

$$P_A + P_B = 700 \text{ MW}$$

For optimum generator  $P_A = ?$ ,  $P_B = ?$

$\therefore$  From curve, maximum incremental cost for generator A  
 $= 600 \text{ at } 450 \text{ MW}$

and maximum incremental cost for generator B  
 $= 800 \text{ at } 400 \text{ MW}$

minimum incremental cost for generator B  
 $= 650 \text{ at } 150 \text{ MW}$

$\therefore$  Maximim incremental cost of generation A is less than the minimum

**SOL 5.33**

To increase capacitive dc voltage slowly to a new steady state value first we have to make  $\delta = -ve$  than we have to reach its original value.

Hence (D) is correct option.

**SOL 5.34**

Given that

$$\text{Reactance of line} = 0.045 \text{ pu} \Rightarrow L = \frac{.045}{2\pi \times 50}$$

$$\text{Susceptance of Line} = 1.2 \text{ pu} \Rightarrow C = \frac{1}{2\pi \times 50} \times \frac{1}{1.2}$$

$$\text{Velocity of wave propagation} = 3 \times 10^5 \text{ Km/sec}$$

$$\text{Length of line } l = ?$$

We know velocity of wave propagation

$$V_x = \frac{l}{\sqrt{LC}}$$

$$l = V_x \sqrt{LC}$$

$$l = 3 \times 10^5 \sqrt{\frac{.45}{2\pi \times 50} \times \frac{1}{2\pi \times 50} \times \frac{1}{1.2}}$$

$$l = 185 \text{ Km}$$

Hence (B) is correct option.

**SOL 5.35**

Due to the fault 'F' at the mid point and the failure of circuit-breaker '4' the sequence of circuit-breaker operation will be 5, 6, 7, 3, 1, 2 (as given in options)

(due to the fault in the particular zone, relay of that particular zone must operate first to break the circuit, then the back-up protection applied if any failure occurs.)

Hence (C) is correct option.

**SOL 5.36**

$$R = [V_{an} \ V_{bn} \ V_{cn}] \begin{bmatrix} 0 & \frac{1}{\sqrt{3}} & -\frac{1}{\sqrt{3}} \\ -\frac{1}{\sqrt{3}} & 0 & \frac{1}{\sqrt{3}} \\ \frac{1}{\sqrt{3}} & -\frac{1}{\sqrt{3}} & 0 \end{bmatrix} \begin{bmatrix} i_a \\ i_b \\ i_c \end{bmatrix}$$

**NOTES**

By solving we get

$$R = \left[ \frac{V_{an}}{\sqrt{3}}(i_b - i_c) + \frac{V_{bn}}{\sqrt{3}}(i_c - i_a) + \frac{V_c}{\sqrt{3}}(i_a - i_b) \right]$$

$$R = 3(VI) , \text{ where } \frac{(i_b - i_c)}{\sqrt{3}} = I \text{ and } V_{an} = V$$

Hence (A) is correct option.

**SOL 5.37**

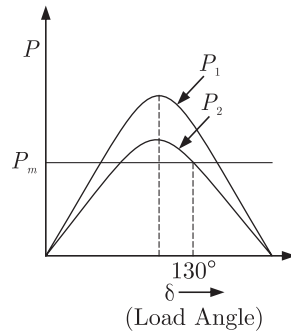

Here  $P_1 \rightarrow$  power before the tripping of one ckt  
 $P_2 \rightarrow$  Power after tripping of one ckt

$$P = \frac{EV}{X} \sin \delta$$

Since  $P_{\max} = \frac{EV}{X}$

$\therefore P_{2\max} = \frac{EX}{X_2}$ , here,  $[X_2 = (0.1 + X) (\text{pu})]$

To find maximum value of  $X$  for which system does not lose synchronism

$$P_2 = P_m \text{ (shown in above figure)}$$

$$\therefore \frac{EV}{X_2} \sin \delta_2 = P_m$$

as  $P_m = 1 \text{ pu}$ ,  $E = 1.0 \text{ pu}$ ,  $V = 1.0 \text{ pu}$

$$\frac{1.0 \times 1.0}{X_2} \sin 130^\circ = 1$$

$$\Rightarrow X_2 = 0.77$$

$$\Rightarrow (0.1 + X) = 0.77$$

$$\Rightarrow X = 0.67$$

Hence (C) is correct option.

**SOL 5.38**

Given that

$$F_P = KAF_S \quad \dots(1)$$

where, Phase component  $F_P = \begin{bmatrix} f_a \\ f_b \\ f_c \end{bmatrix}$ , sequence component  $F_S = \begin{bmatrix} f_p \\ f_n \\ f_o \end{bmatrix}$

and 
$$A = \begin{bmatrix} 1 & 1 & 1 \\ \alpha^2 & \alpha & 1 \\ \alpha & \alpha^2 & 1 \end{bmatrix}$$

$$\therefore \left. \begin{array}{l} V_P = KAV_S \\ I_P = KAI_S \end{array} \right\} \quad \dots(2)$$

and 
$$V_S = Z' [I_S] \quad \dots(3)$$

where 
$$Z' = \begin{bmatrix} 0.5 & 0 & 0 \\ 0 & 0.5 & 0 \\ 0 & 0 & 2.0 \end{bmatrix}$$

We have to find out  $Z$  if  $V_P = ZI_P \quad \dots(4)$

From equation (2) and (3)

$$V_P = KAZ' [I_S]$$

$$V_P = KAZ' \left( \frac{A^{-1}}{K} \right) I_P$$

$$V_P = AZ' A^{-1} I_P \quad \dots(5)$$

$$\therefore A = \begin{bmatrix} 1 & 1 & 1 \\ \alpha^2 & \alpha & 1 \\ \alpha & \alpha^2 & 1 \end{bmatrix}$$

$$\therefore A^{-1} = \frac{\text{Adj } A}{|A|}$$

$$\text{Adj } A = \begin{bmatrix} 1 & \alpha & \alpha^2 \\ 1 & \alpha^2 & \alpha \\ 1 & 1 & 1 \end{bmatrix}$$

$$|A| = \frac{1}{3}$$

$$A^{-1} = \frac{1}{3} \begin{bmatrix} 1 & \alpha & \alpha^2 \\ 1 & \alpha^2 & \alpha \\ 1 & 1 & 1 \end{bmatrix}$$

**NOTES**

Generator feeded to three loads of 4 MW each at 50 Hz.  
Now one load Permanently tripped

$$\therefore f = 48 \text{ Hz}$$

If additional load of 3.5 MW is connected than  $f = ?$

$\therefore$  Change in Frequency w.r.t to power is given as

$$\Delta f = \frac{\text{drop out frequency}}{\text{rated power}} \times \text{Change in power}$$

$$= \frac{5}{15} \times 3.5 = 1.16\%$$

$$= 1.16 \times \frac{50}{100} = 0.58 \text{ Hz}$$

System frequency is =  $50 - 0.58$

$$= 49.42 \text{ Hz}$$

Hence (A) is correct option.

**SOL 5.42**

With the help of physical length of line, we can recognize line as short, medium and long line.

Hence (B) is correct option.

**SOL 5.43**

For capacitor bank switching vacuum circuit breaker is best suited in view of cost and effectiveness.

Hence (A) is correct option.

**SOL 5.44**

Ratio of operating coil current to restraining coil current is known as bias in biased differential relay.

Hence (B) is correct option.

**SOL 5.45**

HVDC links consist of rectifier, inverter, transmission lines etc, where rectifier consumes reactive power from connected AC system and the inverter supplies power to connected AC system.

Hence (B) is correct option.

**SOL 5.46**

Given  $ABCD$  constant of 220 kV line

$$A = D = 0.94 \angle 10^\circ, B = 130 \angle 730^\circ, C = 0.001 \angle 900^\circ, V_S = 240 \text{ kV}$$

% voltage regulation is being given as

$$\% \text{V.R.} = \frac{(V_R)_{\text{No Load}} - (V_R)_{\text{Full load}}}{V_R(\text{Full load})} \times 100$$

At no load  $I_R = 0$

$$(V_R)_{NL} = V_S/A, (V_R)_{\text{Full load}} = 220 \text{ kV}$$

$$\% \text{V.R.} = \frac{\frac{240}{0.94} - 220}{220} \times 100$$

$$\% \text{V.R.} = 16$$

Hence (C) is correct option.

**SOL 5.47**

**SOL 5.48**

Given that,

$$V_{ab1} = X \angle \theta_1, V_{ab2} = Y \angle \theta_2, \text{Phase to neutral sequence volt} = ?$$

First we draw phasor of positive sequence and negative sequence.

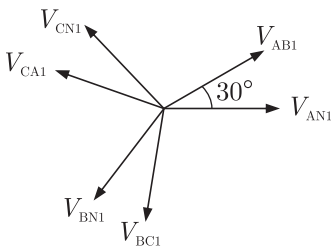

Positive sequence

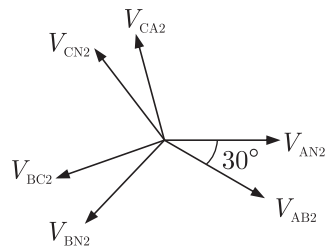

Negative sequence

From figure we conclude that positive sequence line voltage leads phase voltage by  $30^\circ$

$$V_{AN1} = X \angle \theta_1 - 30^\circ$$

$$V_{AN2} = Y \angle \theta_2 + 30^\circ$$

Hence (B) is correct option.

**SOL 5.49**

For system base value 10 MVA, 69 kV, Load in pu( $Z_{\text{new}}$ ) = ?

$$Z_{\text{new}} = Z_{\text{old}} \times \frac{(\text{MVA})_{\text{old}}}{(\text{MVA})_{\text{new}}} \times \left( \frac{\text{kV}_{\text{new}}}{\text{kV}_{\text{old}}} \right)^2$$

**NOTES**

$$Z_{\text{new}} = 0.72 \times \frac{20}{10} \times \left(\frac{69}{13.8}\right)^2$$

$$= 36 \text{ pu}$$

Hence (A) is correct option.

**SOL 5.50**

Unreliable convergence is the main disadvantage of gauss seidel load flow method.

Hence (A) is correct option.

**SOL 5.51**

Generator feeds power to infinite bus through double circuit line 3- $\phi$  fault at middle of line.

$$\text{Infinite bus voltage}(V) = 1 \text{ pu}$$

$$\text{Transient internal voltage of generator}(E) = 1.1 \text{ pu}$$

$$\text{Equivalent transfer admittance during fault} = 0.8 \text{ pu} = 1/X$$

$$\text{delivering power}(P_s) = 1.0 \text{ pu}$$

$$\text{Prior to fault rotor Power angle } \delta = 30^\circ, f = 50 \text{ Hz}$$

$$\text{Initial accelerating power}(P_a) = ?$$

$$P_a = P_s - P_{m2} \sin \delta$$

$$= 1 - \frac{EV}{X} \sin 30^\circ$$

$$= 1 - \frac{1.1 \times 1}{1/0.8} \times \frac{1}{2}$$

$$= 0.56 \text{ pu}$$

Hence (C) is correct option.

**SOL 5.52**

If initial acceleration power =  $X$  pu

$$\text{Initial acceleration} = ?$$

$$\text{Inertia constant} = ?$$

$$\alpha = \frac{P_a}{M} = \frac{X(\text{pu}) \times S}{\text{SH}/180F} = \frac{180 \times 50 \times X \times S}{S \times S}$$

$$\alpha = 1800X \text{ deg/sec}^2$$

$$\text{Inertia const.} = \frac{1}{18}$$

$$= 0.056$$

Hence (B) is correct option.

**SOL 5.53**

The post fault voltage at bus 1 and 3 are.  
Pre fault voltage.

$$V_{\text{Bus}} = \begin{bmatrix} V_1 \\ V_2 \\ V_3 \end{bmatrix} = \begin{bmatrix} 1 \angle 0^\circ \\ 1 \angle 0^\circ \\ 1 \angle 0^\circ \end{bmatrix}$$

At bus 2 solid fault occurs  $Z(f) = 0$ ,  $r = 2$

$$\text{Fault current } I_f = \frac{V_r^\circ}{Z_{rr} + Z_f} = \frac{V_2^\circ}{Z_{22} + Z_f}$$

$$Z_f = \frac{1 \angle 0^\circ}{j0.24} = -4j$$

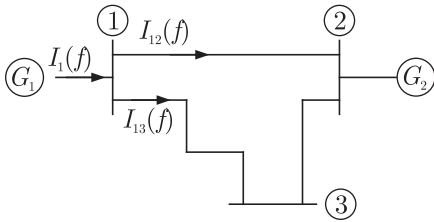

$$V_i(f) = V_i^\circ(0) - Z_{ir} I(f), \quad V_i^\circ = \text{Prefault voltage}$$

$$V_1(f) = V_1^\circ - Z_{12} I_f = 1 \angle 0^\circ - j0.08(-j4) = 1 - 0.32$$

$$V_1(f) = 0.68 \text{ pu}$$

$$V_3(f) = V_3^\circ - Z_{32} I_f = 1 \angle 0^\circ - j0.16(-j4) = 1 - 0.64$$

$$V_3(f) = 0.36 \text{ pu}$$

Hence (D) is correct option.

**SOL 5.54**

**SOL 5.55**

Rating of  $\Delta$ -connected capacitor bank for unity p.f.

real power  $P_L = S \cos \phi = 12\sqrt{3} \times 0.8 = 16.627 \text{ kW}$

reactive power  $Q_L = S \sin \phi = 12\sqrt{3} \times 0.6 = 12.47 \text{ kW}$

For setting of unity p.f. we have to set capacitor bank equal to reactive power = 12.47 kW

Hence (D) is correct option.

**SOL 5.56**

Given that pu parameters of 500 MVA machine are as following



**SOL 5.60**

Parameters of transposed overhead transmission line

$$X_S = 0.4 \Omega/\text{km}, X_m = 0.1 \Omega/\text{km}$$

$$\text{+ve sequence reactance } X_1 = ?$$

$$\text{Zero sequence reactance } X_0 = ?$$

We know for transposed overhead transmission line.

$$\begin{aligned} \text{+ve sequence component } X_1 &= X_S - X_m \\ &= 0.4 - 0.1 = 0.3 \Omega/\text{km} \end{aligned}$$

$$\begin{aligned} \text{Zero sequence component } X_0 &= X_S + 2X_m \\ &= 0.4 + 2(0.1) = 0.6 \Omega/\text{km} \end{aligned}$$

Hence (D) is correct option.

**SOL 5.61**

Industrial substation of 4 MW load =  $P_L$

$$Q_C = 2 \text{ MVAR for load p.f.} = 0.97 \text{ lagging}$$

If capacitor goes out of service than load p.f. = ?

$$\cos \phi = 0.97$$

$$\tan \phi = \tan(\cos^{-1}0.97) = 0.25$$

$$\frac{Q_L - Q_C}{P_L} = 0.25$$

$$\frac{Q_L - 2}{4} = 0.25 \Rightarrow Q_L = 3 \text{ MVAR}$$

$$\phi = \tan^{-1}\left(\frac{Q_L}{P_L}\right) = \tan^{-1}\left(\frac{3}{4}\right) = 36^\circ$$

$$\cos \phi = \cos 36^\circ = 0.8 \text{ lagging}$$

Hence (C) is correct option.

**SOL 5.62**

$$Y_{22} = ?$$

$$\begin{aligned} I_1 &= V_1 Y_{11} + (V_1 - V_2) Y_{12} \\ &= 0.05 V_1 - j10(V_1 - V_2) = -j9.95 V_1 + j10 V_2 \end{aligned}$$

$$\begin{aligned} I_2 &= (V_2 - V_1) Y_{21} + (V_2 - V_3) Y_{23} \\ &= j10 V_1 - j9.9 V_2 - j0.1 V_3 \end{aligned}$$

$$\begin{aligned} Y_{22} &= Y_{11} + Y_{23} + Y_2 \\ &= -j9.95 - j9.9 - 0.1j \\ &= -j19.95 \end{aligned}$$

Hence (D) is correct option.

**NOTES**

**SOL 5.63**

$$F_1 = a + bP_1 + cP_1^2 \text{ Rs/hour}$$

$$F_2 = a + bP_2 + 2cP_2^2 \text{ Rs/hour}$$

For most economical operation

$$P_1 + P_2 = 300 \text{ MW then } P_1, P_2 = ?$$

We know for most economical operation

$$\frac{\partial F_1}{\partial P_1} = \frac{\partial F_2}{\partial P_2}$$

$$2cP_1 + b = 4cP_2 + b$$

$$P_1 = 2P_2 \quad \dots(1)$$

$$P_1 + P_2 = 300 \quad \dots(2)$$

from eq (1) and (2)

$$P_1 = 200 \text{ MW}, P_2 = 100 \text{ MW}$$

Hence (C) is correct option.

**SOL 5.64**

We know that  $ABCD$  parameters  $\begin{bmatrix} V_1 \\ I_1 \end{bmatrix} = \begin{bmatrix} A & B \\ C & D \end{bmatrix} \begin{bmatrix} V_2 \\ I_2 \end{bmatrix}$

$$B = \left. \frac{V_1}{I_2} \right|_{V_2=0}, C = \left. \frac{I_1}{V_2} \right|_{I_2=0}$$

In figure 
$$C = \frac{\frac{V_1}{Z_1 + Z_2}}{\frac{V_1}{Z_1 + Z_2} \times Z_2} = \frac{1}{Z_2}$$

or 
$$Z_2 = \frac{1}{C}$$

$$= \frac{1}{0.025 \angle 45^\circ} = 40 \angle -45^\circ$$

Hence (B) is correct option.

**SOL 5.65**

Given

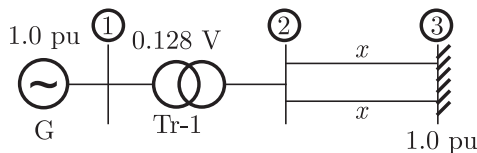

Steady state stability Power Limit = 6.25 pu  
If one of double circuit is tripped than

Steady state stability power limit = ?

$$P_{m1} = \frac{EV}{X} = \frac{1 \times 1}{0.12 + \frac{X}{2}} = 6.25$$

$$\frac{1}{0.12 + 0.5X} = 6.25$$

$$\Rightarrow X = 0.008 \text{ pu}$$

If one of double circuit tripped than

$$P_{m2} = \frac{EV}{X} = \frac{1 \times 1}{0.12 + X} = \frac{1}{0.12 + 0.08}$$

$$P_{m2} = \frac{1}{0.2} = 5 \text{ pu}$$

Hence (D) is correct option.

**SOL 5.66**

Given data

Substation Level = 220 kV

3- $\phi$  fault level = 4000 MVA

LG fault level = 5000 MVA

Positive sequence reactance:

$$\text{Fault current } I_f = \frac{4000}{\sqrt{3} \times 220}$$

$$X_1 = V_{ph} / I_f$$

$$= \frac{\frac{220}{\sqrt{3}}}{\frac{4000}{\sqrt{3} \times 220}} = \frac{220 \times 220}{4000}$$

$$= 12.1 \Omega$$

Hence (D) is correct option.

**SOL 5.67**

Zero sequence Reactance  $X_0 = ?$

$$I_f = \frac{5000}{\sqrt{3} \times 220}$$

$$I_{a1} = I_{a2} = I_{a0} = \frac{I_f}{3} = \frac{5000}{3\sqrt{3} \times 220}$$

**NOTES**

$$X_1 + X_2 + X_0 = \frac{V_{ph}}{I_{a1}} = \frac{\frac{220}{\sqrt{3}}}{\frac{5000}{220 \times 3\sqrt{3}}}$$

$$X_1 + X_2 + X_0 = \frac{220 \times 220}{3 \times 5000} = 29.04 \Omega$$

$$X_1 = X_2 = 12.1 \Omega$$

$$X_0 = 29.04 - 12.1 - 12.1$$

$$= 4.84 \Omega$$

Hence (B) is correct option.

**SOL 5.68**

Instantaneous power supplied by 3- $\phi$  ac supply to a balanced  $R$ - $L$  load.

$$\begin{aligned} P &= V_a I_a + V_b I_b + V_c I_c \\ &= (V_m \sin \omega t) I_m \sin(\omega t - \phi) + V_m \sin(\omega t - 120^\circ) I_m \sin(\omega t - 120^\circ - \phi) \\ &\quad + V_m \sin(\omega t - 240^\circ) I_m \sin(\omega t - 240^\circ - \phi) \\ &= VI[\cos \phi - \cos(2\omega t - \phi) + \cos \phi - \cos(2\omega t - 240 - \phi) + \cos \phi \\ &\quad - \cos(2\omega t + 240 - \phi)] \\ P &= 3VI \cos \phi \quad \dots(1) \end{aligned}$$

equation (1) implies that total instantaneous power is being constant.

Hence (B) is correct option.

**SOL 5.69**

In 3- $\phi$  Power system, the rated voltage is being given by RMS value of line to line voltage.

Hence (C) is correct option.

**SOL 5.70**

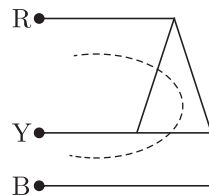

In this figure the sequence is being given as RBY

Hence (B) is correct option.

**NOTES**

**SOL 5.76**

Given data

Lightening stroke discharge impulse current of  $I = 10 \text{ kA}$

Transmission line voltage = 400 kV

Impedance of line  $Z = 250 \Omega$

Magnitude of transient over-voltage = ?

The impulse current will be equally divided in both directions since there is equal distribution on both sides.

Then magnitude of transient over-voltage is

$$\begin{aligned} V &= IZ/2 \\ &= \frac{10}{2} \times 10^3 \times 250 \\ &= 1250 \times 10^3 \text{ V} \\ &= 1250 \text{ kV} \end{aligned}$$

Hence (A) is correct option.

**SOL 5.77**

The  $A, B, C, D$  parameters of line

$$A = D = 0.936 \angle 0.98^\circ$$

$$B = 142 \angle 76.4^\circ$$

$$C = (-5.18 + j914) 10^{-6} \Omega$$

At receiving end  $P_R = 50 \text{ MW}$ ,  $V_R = 220 \text{ kV}$

p.f = 0.9 lagging

$V_S = ?$

Power at receiving end is being given by as follows

$$\begin{aligned} P_R &= \frac{|V_S||V_R|}{|B|} \cos(\beta - \delta) - \frac{|A||V_R|^2}{|B|} \cos(\beta - \alpha) \\ &= \frac{|V_S| \times 220}{142} \cos(76.4^\circ - \delta) - \frac{0.936(220)^2}{142} \cos 75.6^\circ \end{aligned}$$

$$\begin{aligned} \therefore V_S \cos(76.4 - \delta) &= \frac{50 \times 142}{220} + 0.936 \times 220 \times 0.2486 \\ &= 32.27 + 51.19 \end{aligned}$$

$$V_S \cos(76.4 - \delta) = 83.46$$

...(1)

Same as

$$\begin{aligned} Q_R &= P_R \tan \phi \\ &= P_R \tan(\cos^{-1} \phi) = 50 \tan(\cos^{-1} 0.9) \\ &= 24.21 \text{ MW} \end{aligned}$$

$$Q_R = \frac{|V_S||V_R|}{|B|} \sin(\beta - \delta) - \frac{|A||V_R|^2}{|B|} \sin(\beta - \alpha)$$

$$= \frac{|V_S| \times 220}{142} \sin(76.4^\circ - \delta) - \frac{0.936 \times (220)^2}{142} \sin 75.6^\circ$$

$$(24.21) \frac{142}{220} + 0.936 \times 220 \times 0.9685 = |V_S| \sin(76.4^\circ - \delta) \dots (2)$$

from equation (1) & (2)

$$|V_S|^2 = (215)^2 + (83.46)^2$$

$$|V_S| = \sqrt{53190.5716}$$

$$= 230.63 \text{ kV}$$

Hence (C) is correct option.

**SOL 5.78**

A new generator of  $E_g = 1.4 \angle 30^\circ$  pu

$X_S = 1.0$  pu, connected to bus of  $V_t$  Volt

Existing Power system represented by thevenin's equivalent as

$E_{th} = 0.9 \angle 0^\circ$ ,  $Z_{th} = 0.25 \angle 90^\circ$ ,  $V_t = ?$

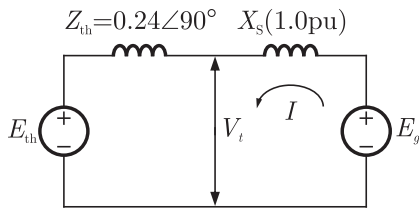

From the circuit given

$$I = \frac{E_g - E_{th}}{Z_{th} + X_S}$$

$$= \frac{1.4 \angle 30^\circ - 0.9 \angle 0^\circ}{j(1.25)} = \frac{1.212 + j7 - 0.9}{j(1.25)}$$

$$= \frac{0.312 + j7}{j(1.25)} = 0.56 - 0.2496j$$

$$V_t = E_g - IX_S$$

$$= 1.212 + j7 - (0.56 - 0.2496j)(j1)$$

$$= 1.212 - 0.2496 + j(0.7 - 0.56)$$

$$= 0.9624 + j0.14$$

$$V_t = 0.972 \angle 8.3^\circ$$

Hence (B) is correct option.

**SOL 5.79**

Given that

3- $\phi$  Generator rated at 110 MVA, 11 kV

Sub transient line current = ?

$$I_{a1} = \frac{E}{Z_1 + Z_2 + Z_0} = \frac{1}{j0.15 + j0.15 + j0.05} = \frac{1}{0.35j} = -2.857j$$

Now sub transient Line current  $I_a = 3I_{a1}$

$$I_a = 3(-2.857j) = -8.57j$$

Hence (D) is correct option.

**SOL 5.82**

Given: 50 Hz, 4-Pole, 500 MVA, 22 kV generator

p.f. = 0.8 lagging

Fault occurs which reduces output by 40%.

Accelerating torque = ?

$$\text{Power} = 500 \times 0.8 = 400 \text{ MW}$$

$$\text{After fault, Power} = 400 \times 0.6 = 240 \text{ MW}$$

$$\therefore P_a = T_a \times \omega$$

$$T_a = \frac{P_a}{\omega}$$

Where

$$\omega = 2\pi f_{\text{mechanical}}$$

$$f_{\text{mechanical}} = f_{\text{electrical}} \times \frac{2}{P}$$

$$= f_{\text{electrical}} \times \frac{2}{4}$$

$$P_a = 400 - 240 = 160 \text{ MW}$$

$$T_a = \frac{160}{2 \times \pi \times 50/2}$$

$$T_a = 1.018 \text{ MN}$$

Hence (B) is correct option.

**SOL 5.83**

Turbine rate speed  $N = 250 \text{ rpm}$

To produce power at  $f = 50 \text{ Hz}$ .

No. of Poles  $P = ?$

$$\therefore N = \frac{120}{P} f$$

$$P = \frac{120}{N} f = \frac{120 \times 50}{250} = 24$$

$$P = 24 \text{ Poles}$$

Hence (D) is correct option.

from eq(1),  $0.5 = \frac{2 \times 1.3}{2.8} \sin(\delta_1 - \delta_2)$

$$\Rightarrow \delta_1 - \delta_2 = \sin^{-1}\left(\frac{2.8 \times 0.5}{2.6}\right)$$

$$\Rightarrow \delta_1 - \delta_2 = 32.58$$

Hence (C) is correct option

**SOL 5.88**

Time period between energization of trip circuit and the arc extinction on an opening operation is known as the interrupting time of Circuit breaker.

Hence (B) is correct option.

**SOL 5.89**

Given that  $ABCD$  parameters of line as

$$A = D = 0.9 \angle 0^\circ, B = 200 \angle 90^\circ \Omega, C = 0.95 \times 10^{-3} \angle 90^\circ \text{ S.}$$

at no-load condition,

Receiving end voltage ( $V_R$ ) = sending end voltage ( $V_S$ )

ohmic value of reactor = ?

We know

$$V_S = A V_R + B I_R$$

$$\because V_S = V_R$$

$$V_R = A V_R + B I_R$$

$$V_R(1 - A) = B I_R$$

$$\frac{V_R}{I_R} = \frac{B}{1 - A}$$

$$= \frac{200 \angle 90^\circ}{1 - 0.9 \angle 0^\circ}$$

$$\frac{V_R}{I_R} = 2000 \angle 90^\circ$$

The ohmic value of reactor =  $2000 \Omega$

Hence (B) is correct option.

**SOL 5.90**

Surge impedance of cable

$$Z_1 = \sqrt{\frac{L}{C}}; \quad L = 0.4 \text{ mH/km}, \quad C = 0.5 \mu\text{F/km}$$

$$= \sqrt{\frac{0.4 \times 10^{-3}}{0.5 \times 10^{-6}}} = 28.284$$



**NOTES**

surge impedance of overhead transmission line

$$Z_2 = Z_3 = \sqrt{\frac{L}{C}}; \quad L = 1.5 \text{ mm/km}, C = 0.015 \mu\text{F/km}$$

$$Z_2 = Z_3 = \sqrt{\frac{1.5 \times 10^{-5}}{0.015 \times 10^{-6}}} = 316.23$$

Now the magnitude of voltage at junction due to surge is being given by as

$$\begin{aligned} V' &= \frac{2 \times V \times Z_2}{Z_2 + Z_1} & V &= 20 \text{ kV} \\ &= \frac{2 \times 20 \times 10^3 \times 316.23}{316 + 28.284} \\ &= 36.72 \text{ kV} \end{aligned}$$

Hence (A) is correct option.

**SOL 5.91**

Let that current in line is  $I$  amp than  
from figure current in line section PR is  $(I - 10)$  amp  
current in line section RS is  $(I - 10 - 20) = (I - 30)$  amp  
current in SQ Section is  $(I - 30 - 30) = (I - 60)$  amp  
Given that  $V_P$  and  $V_Q$  are such that

$$V_P - V_Q = 3 \text{ V}$$

by applying KVL through whole line

$$V_P - V_Q = (I - 10)0.1 + (I - 30)0.15 + (I - 60) \times 0.2$$

$$\Rightarrow 3 = 0.45I - 17.5$$

$$I = \frac{20.5}{0.45} = 45.55 \text{ amp}$$

Now the line drop is being given as

$$\begin{aligned} &= (I - 10)0.1 + (I - 30)0.15 + (I - 60)0.2 \\ &= (33.55)0.1 + (15.55)0.15 + (14.45)0.2 \\ &= 8.58 \text{ V} \end{aligned}$$

The value of  $V_P$  for minimum voltage of 220 V at any feeder is

$$\begin{aligned} &= 220 + \text{Line voltage} \\ &= 220 + 8.58 \\ &= 228.58 \text{ V} \end{aligned}$$

Hence (D) is correct option.

**SOL 5.92**

Given Load Power = 100 MW

$$V_S = V_R = 11 \text{ kV}$$

$$\begin{aligned} \text{Impedance of line } Z_L &= \frac{\text{p.u.} \times (\text{kV})^2}{\text{MV}} \\ &= \frac{j0.2 \times (11)^2}{100} = j0.242 \Omega \end{aligned}$$

$$\begin{aligned} \text{We know } P_L &= \frac{|V_S||V_R|\sin\delta}{X} \\ 100 \times 10^6 &= \frac{11 \times 10^3 \times 11 \times 10^3}{0.242} \sin\delta \end{aligned}$$

$$\frac{100 \times 0.242}{121} = \sin\delta$$

$$\delta = \sin^{-1}(0.2) = 11.537^\circ$$

Reactive Power is being given by

$$\begin{aligned} Q_L &= \frac{|V_S||V_R|}{X} \cos\delta - \frac{|V_R|^2}{X} \\ &= \frac{11 \times 10^3 \times 11 \times 10^3}{0.242} \cos(11.537^\circ) - \frac{(11 \times 10^3)^2}{0.242} \\ &= \frac{121 \times 10^6}{0.242} [\cos(11.537^\circ) - 1] \\ &= -10.1 \text{ MVAR} \end{aligned}$$

Hence (D) is correct option.

**SOL 5.93**

Given the bus Impedance Matrix of a 4-bus Power System

$$Z_{\text{bus}} = \begin{bmatrix} j0.3435 & j0.2860 & j0.2723 & j0.2277 \\ j0.2860 & j0.3408 & j0.2586 & j0.2414 \\ j0.2723 & j0.2586 & j0.2791 & j0.2209 \\ j0.2277 & j0.2414 & j0.2209 & j0.2791 \end{bmatrix}$$

Now a branch of  $j0.2 \Omega$  is connected between bus 2 and reference

$$Z_{B(\text{New})} = Z_{B(\text{Old})} - \frac{1}{Z_{ij} + Z_b} \begin{bmatrix} Z_{ij} \\ \vdots \\ Z_{nj} \end{bmatrix} \begin{bmatrix} Z_{ji} & \cdots & Z_{jn} \end{bmatrix}$$

New element  $Z_b = j0.2 \Omega$  is connected in  $j^{\text{th}}$  and reference bus  
 $j = 2, n = 4$  so

**NOTES**

$$\frac{1}{Z_{ij} + Z_b} \begin{bmatrix} Z_{12} \\ Z_{22} \\ Z_{23} \\ Z_{24} \end{bmatrix} \begin{bmatrix} Z_{21} & Z_{22} & Z_{23} & Z_{24} \end{bmatrix}$$

$$= \frac{1}{[j(0.3408) + j0.2]} \begin{bmatrix} j0.2860 \\ j0.3408 \\ j0.2586 \\ j0.2414 \end{bmatrix} \begin{bmatrix} j0.2860 & j0.3408 & j0.2586 & j0.2414 \end{bmatrix} \dots(1)$$

Given that we are required to change only  $Z_{22}, Z_{23}$

So in equation (1)  $Z'_{22} = \frac{j^2(0.3408)^2}{j(0.5408)} = j0.2147$

$$Z'_{23} = \frac{j^2(0.3408)(0.2586)}{0.5408} = j0.16296$$

$$Z_{22(\text{New})} = Z_{22(\text{Old})} - Z'_{22} = j0.3408 - j0.2147 = j0.1260$$

$$Z_{23(\text{New})} = Z_{23(\text{Old})} - Z'_{23} = j0.2586 - j0.16296 = j0.0956$$

Hence (B) is correct option.

**SOL 5.94**

Total zero sequence impedance, +ve sequence impedance and -ve sequence impedances

$$Z_0 = (Z_0)_{\text{Line}} + (Z_0)_{\text{Generator}} = j0.04 + j0.3 = j0.34 \text{ pu}$$

$$Z_1 = (Z_1)_{\text{Line}} + (Z_1)_{\text{Generator}} = j0.1 + j0.1 = j0.2 \text{ pu}$$

$$Z_2 = (Z_2)_{\text{Line}} + (Z_2)_{\text{Generator}} = j0.1 + j0.1 = j0.2 \text{ pu}$$

$$Z_n = j0.05 \text{ pu}$$

for L-G fault

$$I_{a1} = \frac{E_a}{Z_0 + Z_1 + Z_2 + 3Z_n}$$

$$= \frac{0.1}{j0.2 + j0.2 + j0.34 + j0.15}$$

$$= -j1.12 \text{ pu}$$

$$I_B = \frac{\text{generator MVA}}{\sqrt{3} \text{ generator kV}} = \frac{20 \times 10^6}{\sqrt{3} \times 6.6 \times 10^3} = 1750 \text{ Amp}$$

Fault current

$$I_f = (3I_a) I_B$$

$$= 3(-j1.12)(1750) = -j5897.6 \text{ Amp}$$

Neutral Voltage

$$V_n = I_f Z_n$$

and  $Z_n = Z_B \times Z_{\text{pu}}$

**NOTES**

$$P_{\max} = 2$$

$$P_0 = P_{\max} \sin \delta_0 = 1$$

$$\delta_0 = 30^\circ$$

$$\delta_{\max} = 110^\circ \text{ (given)}$$

Now from equation (1)

$$2 \sin 30^\circ (110 - 30) \frac{\pi}{180} = 2 [\cos \delta_c - \cos 110^\circ]$$

$$0.5 \times \frac{80\pi}{180} = \cos \delta_c + 0.342$$

$$\cos \delta_c = 0.698 - 0.342$$

$$\delta_c = 69.138^\circ$$

Hence (C) is correct option.

**SOL 5.98**

$\therefore$  Both sides are granted

$$\text{So, } I_a = \frac{E_a}{Z_a} = \frac{10 \angle 0^\circ}{2j} = 5 \angle -90^\circ$$

$$I_b = \frac{E_b}{Z_b} = \frac{10 \angle -90^\circ}{3j} = 3.33 \angle -180^\circ$$

$$I_c = \frac{E_c}{Z_c} = \frac{10 \angle 120^\circ}{4j} = 2.5 \angle 30^\circ$$

$$\text{We know } I_{a1} = \frac{1}{3} [I_a + \alpha I_b + \alpha^2 I_c]$$

$$\text{where } \alpha = 1 \angle 120^\circ \Rightarrow \alpha^2 = 1 \angle 240^\circ$$

$$I_{a1} = \frac{1}{3} [5 \angle -90^\circ + 3.33 \angle (-180^\circ + 120^\circ) + 2.5 \angle (240^\circ + 30^\circ)]$$

$$I_{a1} = \frac{1}{3} [5 \angle -90^\circ + 3.33 \angle -60^\circ + 2.5 \angle 270^\circ]$$

$$= \frac{1}{3} [-5j + 1.665 - j2.883 - 2.5j]$$

$$= \frac{1}{3} [1.665 - j10.383]$$

$$= 3.5 \angle -80.89^\circ$$

Hence (D) is correct option.

**SOL 5.99**

Given data

$$\text{A balanced delta connected load} = 8 + 6j = 2$$

$$V_2 = 400 \text{ volt}$$

Improved Power Factor  $\cos \phi_2 = 0.9$

$$\phi_1 = \tan^{-1}(6/8) = 36.85^\circ$$

$$\phi_2 = \cos^{-1}(0.9) = 25.84^\circ$$

$$I = \frac{V}{Z} = \frac{400}{8 + 6j} = \frac{400}{10 \angle 36.86^\circ} = 40 \angle -36.86^\circ$$

$$I = 32 - j24$$

Since Power factor is Improved by connecting a Y-connected capacitor bank like as

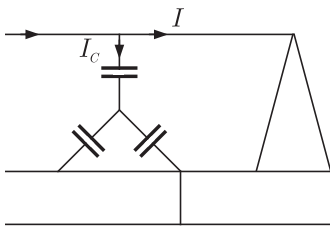

Phasor diagram is being given by as follows

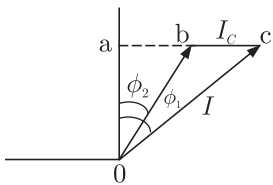

In figure  $oa = I' \cos \phi_2 = I \cos \phi_1$

$$I' \cos 25.84^\circ = 32$$

$$I' \times 0.9 = 32$$

$$I' = 35.55$$

$$ac = 24 \text{ Amp.} \quad (ac = I \sin \phi_1)$$

$$ab = I' \sin \phi_2 = 35.55 \sin 25.84^\circ$$

$$ab = 15.49 \text{ Amp}$$

$$I_c = bc = ac - ab = 24 - 15.49 = 8.51 \text{ Amp}$$

$$\text{KVAR of Capacitor bank} = \frac{3 \times V \times I_c}{1000}$$

$$= \frac{3 \times 400 \times 8.51}{1000}$$

$$= 10.2 \text{ KVAR}$$

Hence (B) is correct option.

**SOL 5.104**

Given that  $X_S = 0.2$  pu

Mid point voltage of transmission line = 0.98 pu

$$V_S = V_R = 1$$

Steady state power transfer limit

$$P = \frac{V_S V_R}{X_S} \sin \delta = \frac{1 \cdot 1}{0.2} \sin 90^\circ = 5 \text{ pu}$$

Hence (D) is correct option.

**SOL 5.105**

We have to find out the thevenin's equivalent zero sequence impedance  $Z_0$  at point B. The zero sequence network of system can be drawn as follows

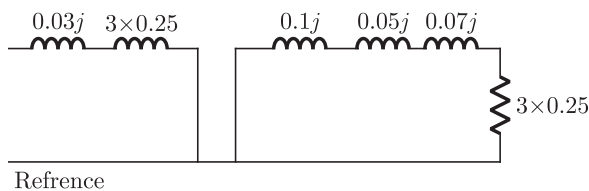

equivalent zero sequence impedance is being given as follows

$$Z_0 = 0.1j + 0.05j + 0.07j + (3 \times 0.25)$$

$$Z_0 = 0.75 + j0.22$$

Hence (B) is correct option.

**SOL 5.106\***

Given data :

$$Z_C = 400 \Omega \text{ (Characteristics Impedance)}$$

$$\beta = 1.2 \times 10^{-3} \text{ rad/km (Propagation constant)}$$

$$l = 100 \text{ km (length of line)}$$

$$P_{\max} = ? \text{ If } V_S = 230 \text{ kV}$$

$$V_S = V_R \cos(\beta l) + jZ_C \sin(\beta l) I_R$$

$$\therefore V_S = A V_R + B I_R$$

$$A = \cos \beta l$$

$$= \cos(1.2 \times 10^{-3} \times 100) = 0.9928 \angle 0^\circ$$

$$B = jZ_C \sin(\beta l)$$

$$= j400 \sin(1.2 \times 10^{-3} \times 100) = j47.88$$

$$= 47.88 \angle 90^\circ$$

$$V_S = 230 \text{ kV}, l = 100 \text{ km}$$

Since it is a short line, so  $V_S \simeq V_R = 230 \text{ kV}$

**NOTES**

again we know for transmission line the equation

$$(P_r - P_{r0})^2 + (Q_r - Q_{r0}) = P_r^2 \quad \dots(1)$$

Where  $P_{r0} = -\frac{A V_R^2}{B} \cos(\beta - \alpha) \text{ MW}$

$$Q_{r0} = -\frac{A V_R^2}{B} \sin(\beta - \alpha) \text{ MW}$$

$$P_r = \frac{V_S V_R}{B} \text{ MVA}$$

and maximum power transferred is being given by as

$$P_{rm} = |P_r| - |P_{r0}|$$

$$P_r = \frac{V_S V_R}{B} = \frac{230 \times 230}{47.88}$$

$$P_r = 1104.84 \text{ MVA}$$

$$P_{r0} = -\frac{A V_R^2}{B} \cos(\beta - \alpha) \text{ MW}$$

$$= -\frac{0.9928 \times (230)^2}{47.88} \times \cos(90^\circ - 0)$$

$$P_{r0} = 0 \text{ MW}$$

So maximum Power transferred

$$\begin{aligned} P_{rm} &= |P_r| - |P_{r0}| \\ &= 1104.84 \text{ MW} \end{aligned}$$

**SOL 5.107\***

Given: two transposed 3- $\phi$  line run parallel to each other.

The equation for voltage drop in both side are given as

$$\begin{bmatrix} \Delta V_{a1} \\ \Delta V_{b1} \\ \Delta V_{c1} \\ \Delta V_{a2} \\ \Delta V_{b2} \\ \Delta V_{c2} \end{bmatrix} = j \begin{bmatrix} 0.15 & 0.05 & 0.05 & 0.04 & 0.04 & 0.04 \\ 0.05 & 0.15 & 0.05 & 0.04 & 0.04 & 0.04 \\ 0.05 & 0.05 & 0.15 & 0.04 & 0.04 & 0.04 \\ 0.04 & 0.04 & 0.04 & 0.15 & 0.05 & 0.05 \\ 0.04 & 0.04 & 0.04 & 0.05 & 0.15 & 0.05 \\ 0.04 & 0.04 & 0.04 & 0.05 & 0.05 & 0.15 \end{bmatrix} \begin{bmatrix} I_{a1} \\ I_{b1} \\ I_{c1} \\ I_{a2} \\ I_{b2} \\ I_{c2} \end{bmatrix}$$

We have to compute self and mutual zero sequence impedance of the system i.e.  $Z_{011}, Z_{012}, Z_{021}, Z_{022}$  in the following equation.

$$\Delta V_{01} = Z_{011} I_{01} + Z_{021} I_{02}$$

$$\Delta V_{02} = Z_{021} I_{01} + Z_{022} I_{02}$$

We know that +ve, -ve and zero sequence Impedance can be calculated as respectively.

**NOTES**

$$\frac{d\delta}{dt} = 104.72 \cos \delta + \delta_0$$

$$\because \delta_0 = 0 \text{ (given)}$$

$$\omega = \frac{d\delta}{dt}$$

$$\text{For } (\omega_{\text{init}})_{\text{max}} = \left(\frac{d\delta}{dt}\right)_{\text{max}}$$

$$\left(\frac{d\delta}{dt}\right)_{\text{max}} \text{ when } \cos \delta = 1$$

$$(\omega_{\text{init}})_{\text{max}} = \left(\frac{d\delta}{dt}\right)_{\text{max}} = 104.72 \text{ rad/sec}$$

**SOL 5.109**

A lossless radial transmission line with surge impedance loading has flat voltage profile and unity power factor at all points along it. Hence (C) is correct option.

**SOL 5.110**

Given that 3- $\phi$  transformer, 20 MVA, 220 kV(Y) - 33 kV( $\Delta$ )

$$X_l = \text{leakage Reactance} = 12\%$$

$$X = \text{referred to LV in each phase} = ?$$

$$X = 3 \times \frac{(\text{LV side voltage})^2}{\text{MVA Rating}} \times \text{Reactance of Leakage}$$

$$X = 3 \times \frac{(33 \text{ kV})^2}{20 \text{ MVA}} \times 0.12$$

$$= 19.6 \Omega$$

Hence (B) is correct option.

**SOL 5.111**

Given 75 MVA, 10 kV synchronous generator

$$X_d = 0.4 \text{ pu}$$

We have to find out  $(X_d)_{\text{new}}$  at 100 MVA, 11 kV

$$(X_d)_{\text{new}} = (X_d)_{\text{old}} \times \left[ \frac{(\text{kV})_{\text{old}}}{(\text{kV})_{\text{new}}} \right]^2 \times \left[ \frac{(\text{MVA})_{\text{new}}}{(\text{MVA})_{\text{old}}} \right]$$

$$(X_d)_{\text{new}} = 0.4 \times \left( \frac{10}{11} \right)^2 \times \frac{100}{75} = 0.44 \text{ pu}$$

Hence (D) is correct option.



**SOL 5.112**

Given Y-alternator: 440 V, 50 Hz

Per phase  $X_s = 10 \Omega$ , Capacitive Load current  $I = 20 \text{ A}$

For zero voltage regulation load p.f = ?

Let Load  $Z = R + jX$

$\therefore$  Zero voltage regulation is given so

$$\overline{E}_{\text{Ph}} - IX_s - I(R + jX) = 0$$

$$\frac{440}{\sqrt{3}} - 20(j10) - 20(R + jX) = 0 \quad \dots(1)$$

separating real and imaginary part of equation (1)

$$20R = \frac{440}{\sqrt{3}}$$

$$R = \frac{22}{\sqrt{3}}$$

and  $20(X + 10) = \frac{440}{\sqrt{3}}$

$$X = \frac{22}{\sqrt{3}} - 10 = \frac{4.68}{\sqrt{3}}$$

$$\theta = \tan^{-1} \frac{X}{R} = \tan^{-1} \left( \frac{4.68/\sqrt{3}}{22/\sqrt{3}} \right) = \tan^{-1} \left( \frac{4.68}{22} \right)$$

and power factor  $\cos \theta = \cos \left( \tan^{-1} \frac{4.68}{22} \right)$

$$\cos \theta = 0.82$$

Hence (A) is correct option.

**SOL 5.113**

Given 240 V, 1- $\phi$  AC source, Load Impedance  $Z = 10 \angle 60^\circ \Omega$

Capacitor is in parallel with load and supplies 1250 VAR

The real power  $P$  by source = ?

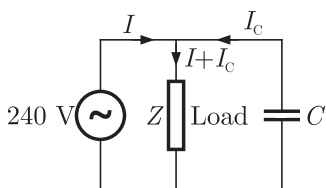

from figure current through load  $I_L = I + I_c$

**SOL 5.118\***

We have to draw reactance diagram for given  $Y_{\text{Bus}}$  matrix

$$Y_{\text{Bus}} = j \begin{bmatrix} -6 & 2 & 2.5 & 0 \\ 2 & -10 & 2.5 & 4 \\ 2.5 & 2.5 & -9 & 4 \\ 0 & 4 & 4 & -8 \end{bmatrix}$$

$\therefore$  It is  $4 \times 4$  matrix (admittance matrix) as

$$Y_{\text{Bus}} = \begin{bmatrix} y_{11} & y_{12} & y_{13} & y_{14} \\ y_{21} & y_{22} & y_{23} & y_{24} \\ y_{31} & y_{32} & y_{33} & y_{34} \\ y_{41} & y_{42} & y_{43} & y_{44} \end{bmatrix}$$

Here diagonal elements

$$y_{11} = y_{10} + y_{12} + y_{13} + y_{14} = -6j \quad \dots(1)$$

$$y_{22} = y_{20} + y_{21} + y_{23} + y_{24} = -10j \quad \dots(2)$$

$$y_{33} = y_{30} + y_{31} + y_{32} + y_{34} = -9j \quad \dots(3)$$

$$y_{44} = y_{40} + y_{41} + y_{42} + y_{43} = -9j \quad \dots(4)$$

and diagonal elements

$$\left. \begin{aligned} y_{12} = y_{21} = -y_{12} = 2j \\ y_{13} = y_{31} = -y_{13} = 2.5j \\ y_{14} = y_{41} = -y_{14} = 0j \\ y_{23} = y_{32} = -y_{23} = 2.5j \\ y_{24} = y_{42} = -y_{24} = 4j \\ y_{34} = y_{43} = 4j \end{aligned} \right\} \dots(5)$$

from equation (1)  $y_{10} = y_{11} - y_{12} - y_{13} - y_{14}$   
 $y_{10} = -6j + 2j + 2.5j + 0j = -1.5j$

Same as from equation (2)  $y_{20} = y_{22} - y_{21} - y_{23} - y_{24}$   
 $y_{20} = -10j + 2j + 2.5j + 4j = -1.5j$

from equation (3)  $y_{30} = y_{33} - y_{31} - y_{32} - y_{34}$   
 $y_{30} = -9j + 2.5j + 2.5j + 4j = 0$

from equation (4)  $y_{40} = y_{44} - y_{41} - y_{42} - y_{43}$   
 $y_{40} = -8j + 0 + 4j + 4j = 0$

Now we have to draw the reactance diagram as follows

**NOTES**

$$+ P_{\max 111} (\cos \delta_{\max} - \cos \delta_{cr}) = 0$$

$$\Rightarrow \cos \delta_{cr} = \frac{P_m (\delta_{\max} - \delta_0) - P_{\max 11} \cos \delta_0 + P_{\max 111} \cos \delta_{\max}}{P_{\max 111} - P_{\max 11}}$$

$$= \frac{1(2.41 - 0.52) - 0.5 \cos(0.52) + 1.5 \cos(2.41)}{1.5 - 0.5}$$

$$\cos \delta_{cr} = 0.35$$

$$\delta_{cr} = \cos^{-1} 0.35$$

$$= 1.21 \text{ rad}$$

**SOL 5.120\***

Given: L - G fault on unloaded generator

$$Z_0 = j0.15, Z_1 = j0.25, Z_2 = j0.25 \text{ pu}, Z_n = j0.05 \text{ pu}$$

$$V_{\text{prefault}} = 1 \text{ pu}$$

$$I_f = ?$$

$$\text{fault Current } I_f = 3I_{a1} = \frac{3V_{\text{prefault}}}{Z_1 + Z_2 + Z_0 + 3Z_n}$$

$$= \frac{3 \times 1}{(j0.25 + j0.25 + j0.15) + 3(j0.05)}$$

$$I_f = \frac{3}{0.80j} = -3.75j$$

Sequence network is being drawn as follows

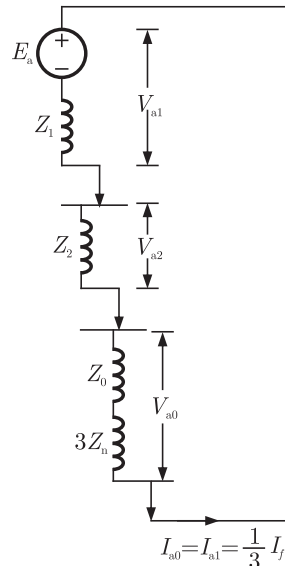

**SOL 5.121\***

Given power system has two generator

$$\text{Generator - 1; } C_1 = 0.006P_{G1}^2 + 8P_{G1} + 350$$

$$\text{Generator - 2; } C_2 = 0.009P_{G2}^2 + 7P_{G2} + 400$$

$$\text{Generator Limits are } 100 \text{ MW} \leq P_{G1} \leq 650 \text{ MW}$$

$$50 \text{ MW} \leq P_{G2} \leq 500 \text{ MW}$$

$$P_{G1} + P_{G2} = 600 \text{ MW, } P_{G1}, P_{G2} = ? \text{ For optimal generation}$$

We know for optimal Generation

$$\frac{\partial C_1}{\partial P_{G1}} = \frac{\partial C_2}{\partial P_{G2}} \quad \dots(1)$$

$$\frac{\partial C_1}{\partial P_{G1}} = 0.012P_{G1} + 8$$

$$\frac{\partial C_2}{\partial P_{G2}} = 0.018P_{G2} + 7$$

from equation (1)

$$0.012P_{G1} + 8 = 0.018P_{G2} + 7$$

$$0.012P_{G1} - 0.018P_{G2} = -1 \quad \dots(2)$$

$$P_{G1} + P_{G2} = 600 \quad \dots(3)$$

From equation (2)

$$0.012P_{G1} - 0.018(600 - P_{G1}) = -1$$

$$\Rightarrow 0.03P_{G1} = 9.8$$

$$\Rightarrow P_{G1} = 326.67 \text{ MW}$$

$$P_{G2} = 600 - P_{G1} = 600 - 326.67 \\ = 273.33 \text{ MW}$$

\*\*\*\*\*

Blank

# 6

## CHAPTER

# CONTROL SYSTEMS

YEAR 2010

TWO MARKS

### MCQ 6.1

The frequency response of

$$G(s) = \frac{1}{s(s+1)(s+2)}$$

plotted in the complex  $G(j\omega)$  plane (for  $0 < \omega < \infty$ ) is

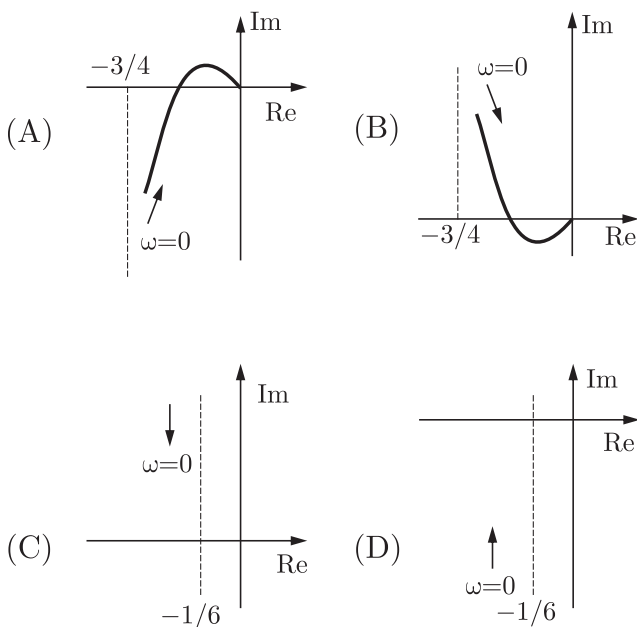

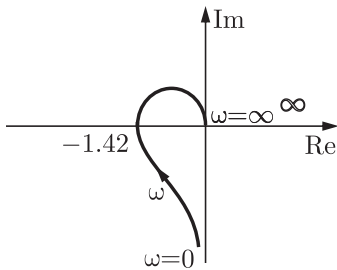

- (A) always stable
- (B) marginally stable
- (C) un-stable with one pole on the RH  $s$ -plane
- (D) un-stable with two poles on the RH  $s$ -plane

**MCQ 6.6**

The first two rows of Routh's tabulation of a third order equation are as follows.

$$\begin{array}{r} s^3 \quad 2 \quad 2 \\ s^2 \quad 4 \quad 4 \end{array}$$

This means there are

- (A) Two roots at  $s = \pm j$  and one root in right half  $s$ -plane
- (B) Two roots at  $s = \pm j\sqrt{2}$  and one root in left half  $s$ -plane
- (C) Two roots at  $s = \pm j\sqrt{2}$  and one root in right half  $s$ -plane
- (D) Two roots at  $s = \pm j$  and one root in left half  $s$ -plane

**MCQ 6.7**

The asymptotic approximation of the log-magnitude v/s frequency plot of a system containing only real poles and zeros is shown. Its transfer function is

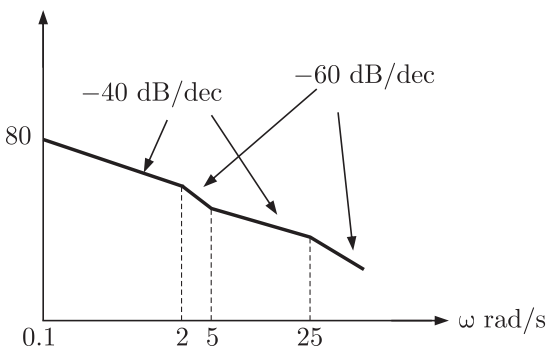

**NOTES**

(A)  $\frac{10(s+5)}{s(s+2)(s+25)}$

(B)  $\frac{1000(s+5)}{s^2(s+2)(s+25)}$

(C)  $\frac{100(s+5)}{s(s+2)(s+25)}$

(D)  $\frac{80(s+5)}{s^2(s+2)(s+25)}$

**YEAR 2009**

**TWO MARKS**

**MCQ 6.8**

The unit-step response of a unity feed back system with open loop transfer function  $G(s) = K/((s+1)(s+2))$  is shown in the figure.

The value of  $K$  is

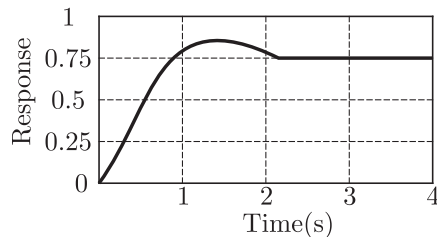

(A) 0.5

(B) 2

(C) 4

(D) 6

**MCQ 6.9**

The open loop transfer function of a unity feed back system is given by  $G(s) = (e^{-0.1s})/s$ . The gain margin of the system is

(A) 11.95 dB

(B) 17.67 dB

(C) 21.33 dB

(D) 23.9 dB

**Common Data for Question 10 and 11 :**

A system is described by the following state and output equations

$$\frac{dx_1(t)}{dt} = -3x_1(t) + x_2(t) + 2u(t)$$

$$\frac{dx_2(t)}{dt} = -2x_2(t) + u(t)$$

$$y(t) = x_1(t)$$



**NOTES**

- (A) 0 (B) 0.5  
(C) 1 (D) 2

**MCQ 6.14**

The transfer functions of two compensators are given below :

$$C_1 = \frac{10(s+1)}{(s+10)}, \quad C_2 = \frac{s+10}{10(s+1)}$$

Which one of the following statements is correct ?

- (A)  $C_1$  is lead compensator and  $C_2$  is a lag compensator  
(B)  $C_1$  is a lag compensator and  $C_2$  is a lead compensator  
(C) Both  $C_1$  and  $C_2$  are lead compensator  
(D) Both  $C_1$  and  $C_2$  are lag compensator

**MCQ 6.15**

The asymptotic Bode magnitude plot of a minimum phase transfer function is shown in the figure :

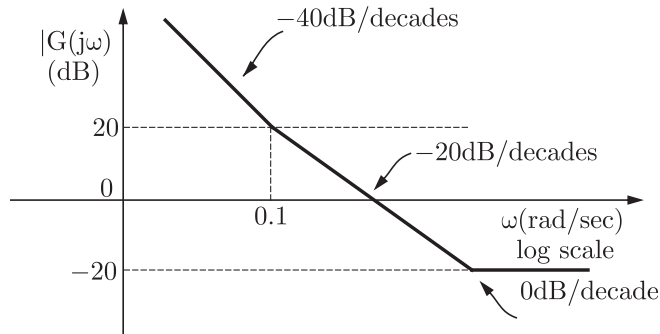

This transfer function has

- (A) Three poles and one zero (B) Two poles and one zero  
(C) Two poles and two zero (D) One pole and two zeros

**MCQ 6.16**

Figure shows a feedback system where  $K > 0$

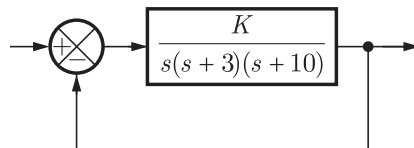



**NOTES**

(C)  $X = c_1 s + c_0, Y = (b_1 s + b_0) / (s^2 + a_1 s + a_0), Z = 1$

(D)  $X = c_1 s + c_0, Y = 1 / (s^2 + a_1 s + a), Z = b_1 s + b_0$

**MCQ 6.25**

Consider the feedback system shown below which is subjected to a unit step input. The system is stable and has following parameters  $K_p = 4, K_i = 10, \omega = 500$  and  $\xi = 0.7$ . The steady state value of  $Z$  is

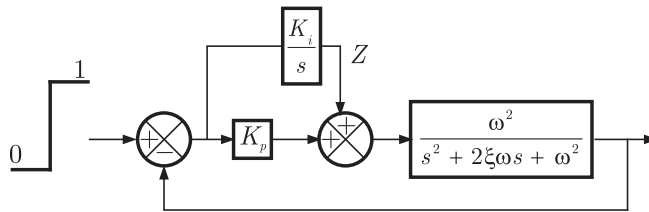

- (A) 1 (B) 0.25  
(C) 0.1 (D) 0

**Data for Q.26 and Q.27 are given below. Solve the problems and choose the correct answers.**

R-L-C circuit shown in figure

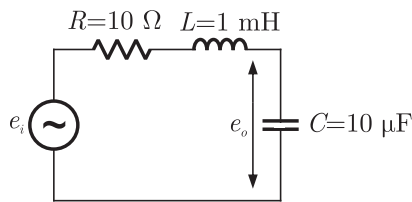

**MCQ 6.26**

For a step-input  $e_i$ , the overshoot in the output  $e_0$  will be

- (A) 0, since the system is not under damped  
(B) 5 %  
(C) 16 % (D) 48 %

**NOTES**

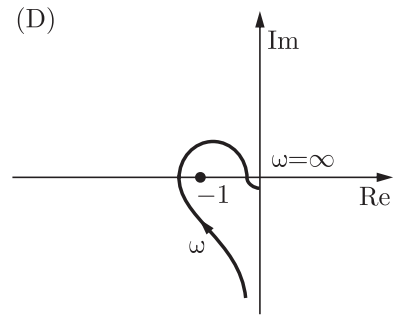
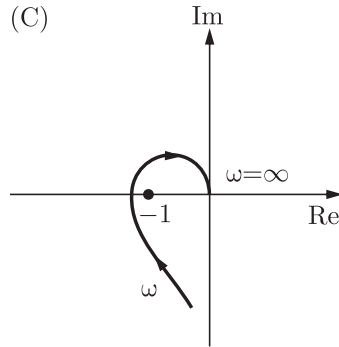

(A) (1) only

(B) all, except (1)

(C) all, except (3)

(D) (1) and (2) only

**MCQ 6.30**

The Bode magnitude plot  $H(j\omega) = \frac{10^4(1 + j\omega)}{(10 + j\omega)(100 + j\omega)^2}$  is

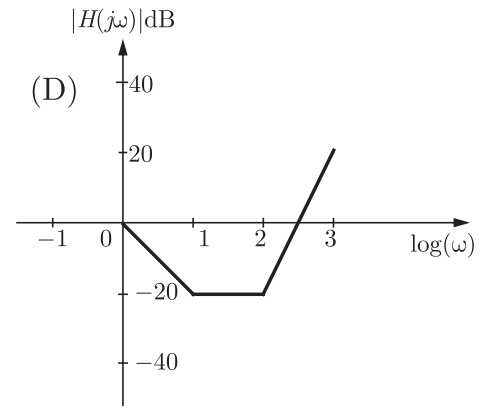
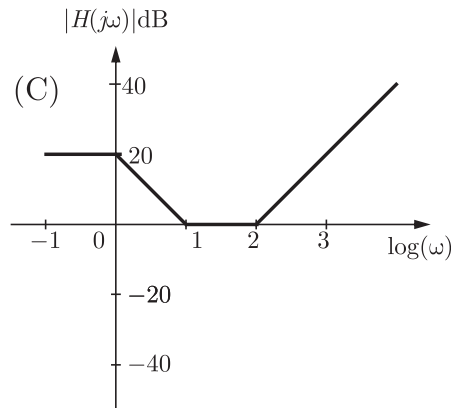
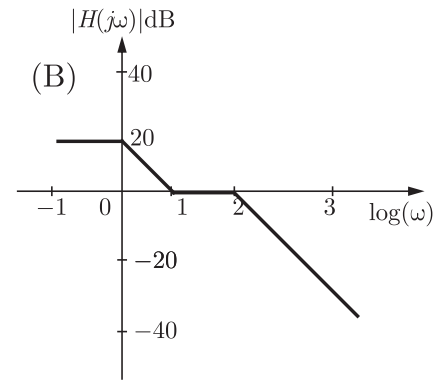
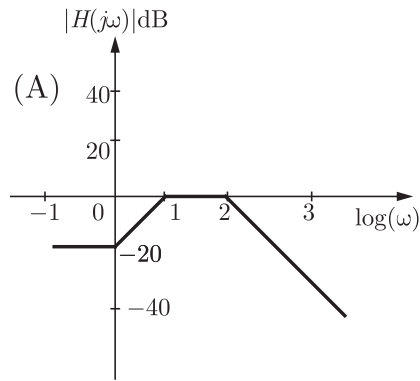

**MCQ 6.31**

A closed-loop system has the characteristic function  $(s^2 - 4)(s + 1) + K(s - 1) = 0$ . Its root locus plot against  $K$  is

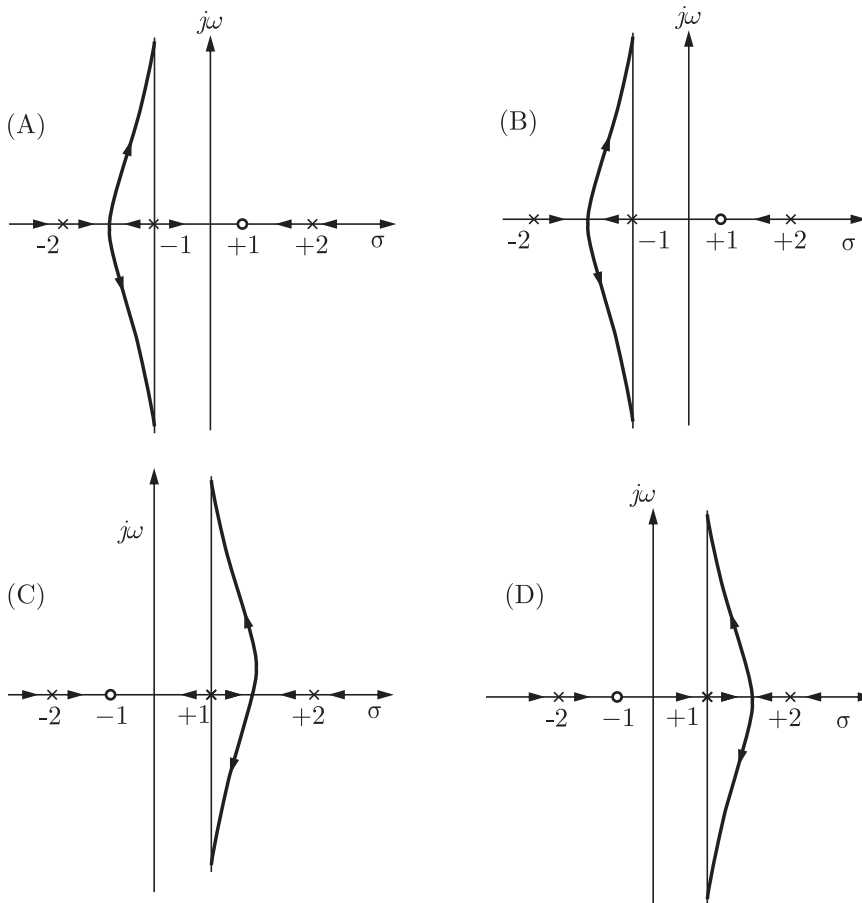

**YEAR 2005**

**ONE MARK**

**MCQ 6.32**

A system with zero initial conditions has the closed loop transfer function.

$$T(s) = \frac{s^2 + 4}{(s + 1)(s + 4)}$$

The system output is zero at the frequency

- (A) 0.5 rad/sec
- (B) 1 rad/sec
- (C) 2 rad/sec
- (D) 4 rad/sec



**NOTES**

**MCQ 6.39**

The state transition matrix

- (A)  $\begin{bmatrix} 1 & \frac{1}{3}(1 - e^{-3t}) \\ 0 & e^{-3t} \end{bmatrix}$       (B)  $\begin{bmatrix} 1 & \frac{1}{3}(e^{-t} - e^{-3t}) \\ 0 & e^{-t} \end{bmatrix}$
- (C)  $\begin{bmatrix} 1 & \frac{1}{3}(e^{3-t} - e^{-3t}) \\ 0 & e^{-3t} \end{bmatrix}$       (D)  $\begin{bmatrix} 1 & (1 - e^{-t}) \\ 0 & e^{-t} \end{bmatrix}$

**MCQ 6.40**

The state transition equation

- (A)  $\mathbf{X}(t) = \begin{bmatrix} t - e^{-t} \\ e^{-t} \end{bmatrix}$       (B)  $\mathbf{X}(t) = \begin{bmatrix} 1 - e^{-t} \\ 3e^{-3t} \end{bmatrix}$
- (C)  $\mathbf{X}(t) = \begin{bmatrix} t - e^{3t} \\ 3e^{-3t} \end{bmatrix}$       (D)  $\mathbf{X}(t) = \begin{bmatrix} t - e^{-3t} \\ e^{-t} \end{bmatrix}$

**YEAR 2004**

**ONE MARK**

**MCQ 6.41**

The Nyquist plot of loop transfer function  $G(s)H(s)$  of a closed loop control system passes through the point  $(-1, j0)$  in the  $G(s)H(s)$  plane. The phase margin of the system is

- (A)  $0^\circ$       (B)  $45^\circ$   
(C)  $90^\circ$       (D)  $180^\circ$

**MCQ 6.42**

Consider the function,

$$F(s) = \frac{5}{s(s^2 + 3s + 2)}$$

where  $F(s)$  is the Laplace transform of the of the function  $f(t)$ . The initial value of  $f(t)$  is equal to

- (A) 5      (B)  $\frac{5}{2}$   
(C)  $\frac{5}{3}$       (D) 0

**MCQ 6.43**

For a tachometer, if  $\theta(t)$  is the rotor displacement in radians,  $e(t)$  is the output voltage and  $K_t$  is the tachometer constant in V/rad/sec, then the transfer function,  $\frac{E(s)}{Q(s)}$  will be

- (A)  $K_t s^2$  (B)  $K_t/s$   
(C)  $K_t s$  (D)  $K_t$

**YEAR 2004**

**TWO MARKS**

**MCQ 6.44**

For the equation,  $s^3 - 4s^2 + s + 6 = 0$  the number of roots in the left half of  $s$ -plane will be

- (A) Zero (B) One  
(C) Two (D) Three

**MCQ 6.45**

For the block diagram shown in figure, the transfer function  $\frac{C(s)}{R(s)}$  is equal to

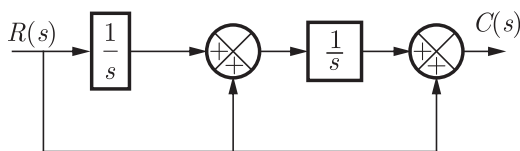

- (A)  $\frac{s^2 + 1}{s^2}$  (B)  $\frac{s^2 + s + 1}{s^2}$   
(C)  $\frac{s^2 + s + 1}{s}$  (D)  $\frac{1}{s^2 + s + 1}$

**MCQ 6.46**

The state variable description of a linear autonomous system is,  $\dot{\mathbf{X}} = \mathbf{A}\mathbf{X}$  where  $\mathbf{X}$  is the two dimensional state vector and  $\mathbf{A}$  is the system matrix given by  $\mathbf{A} = \begin{bmatrix} 0 & 2 \\ 2 & 0 \end{bmatrix}$ . The roots of the characteristic equation are

- (A)  $-2$  and  $+2$  (B)  $-j2$  and  $+j2$   
(C)  $-2$  and  $-2$  (D)  $+2$  and  $+2$



- (A) 0.141 (B) 0.441  
(C) 0.841 (D) 1.141

**YEAR 2003**

**ONE MARK**

**MCQ 6.51**

A control system is defined by the following mathematical relationship

$$\frac{d^2x}{dt^2} + 6\frac{dx}{dt} + 5x = 12(1 - e^{-2t})$$

The response of the system as  $t \rightarrow \infty$  is

- (A)  $x = 6$  (B)  $x = 2$   
(C)  $x = 2.4$  (D)  $x = -2$

**MCQ 6.52**

A lead compensator used for a closed loop controller has the following transfer function

$$\frac{K(1 + \frac{s}{a})}{(1 + \frac{s}{b})}$$

For such a lead compensator

- (A)  $a < b$  (B)  $b < a$   
(C)  $a > Kb$  (D)  $a < Kb$

**MCQ 6.53**

A second order system starts with an initial condition of  $\begin{bmatrix} 2 \\ 3 \end{bmatrix}$  without any external input. The state transition matrix for the system is given by  $\begin{bmatrix} e^{-2t} & 0 \\ 0 & e^{-t} \end{bmatrix}$ . The state of the system at the end of 1 second is given by

- (A)  $\begin{bmatrix} 0.271 \\ 1.100 \end{bmatrix}$  (B)  $\begin{bmatrix} 0.135 \\ 0.368 \end{bmatrix}$   
(C)  $\begin{bmatrix} 0.271 \\ 0.736 \end{bmatrix}$  (D)  $\begin{bmatrix} 0.135 \\ 1.100 \end{bmatrix}$



**NOTES**

- (A)  $4.9^\circ$ , 0.97 dB                      (B)  $5.7^\circ$ , 3 dB  
(C)  $4.9^\circ$ , 3 dB                              (D)  $5.7^\circ$ , 0.97 dB

**MCQ 6.60**

The block diagram of a control system is shown in figure. The transfer function  $G(s) = Y(s) / U(s)$  of the system is

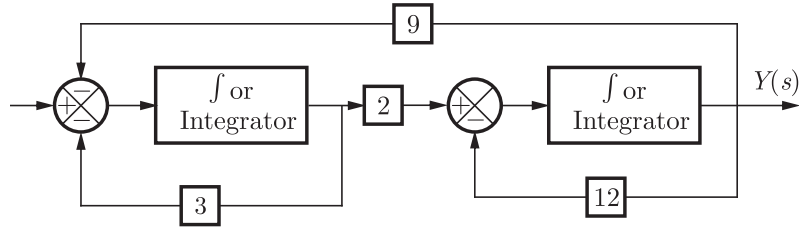

- (A)  $\frac{1}{18(1 + \frac{s}{12})(1 + \frac{s}{3})}$                       (B)  $\frac{1}{27(1 + \frac{s}{6})(1 + \frac{s}{9})}$   
(C)  $\frac{1}{27(1 + \frac{s}{12})(1 + \frac{s}{9})}$                       (D)  $\frac{1}{27(1 + \frac{s}{9})(1 + \frac{s}{3})}$

**YEAR 2002** **ONE MARK**

**MCQ 6.61**

The state transition matrix for the system  $\dot{\mathbf{X}} = \mathbf{A}\mathbf{X}$  with initial state  $\mathbf{X}(0)$  is

- (A)  $(sI - A)^{-1}$   
(B)  $e^{At} \mathbf{X}(0)$   
(C) Laplace inverse of  $[(sI - A)^{-1}]$   
(D) Laplace inverse of  $[(sI - A)^{-1} \mathbf{X}(0)]$

**YEAR 2002** **TWO MARKS**

**MCQ 6.62**

For the system  $\dot{\mathbf{X}} = \begin{bmatrix} 2 & 3 \\ 0 & 5 \end{bmatrix} \mathbf{X} + \begin{bmatrix} 1 \\ 0 \end{bmatrix} \mathbf{u}$ , which of the following statements is true ?

- (A) The system is controllable but unstable  
(B) The system is uncontrollable and unstable

- (C) The system is controllable and stable  
(D) The system is uncontrollable and stable

**MCQ 6.63**

A unity feedback system has an open loop transfer function,  $G(s) = \frac{K}{s^2}$ . The root locus plot is

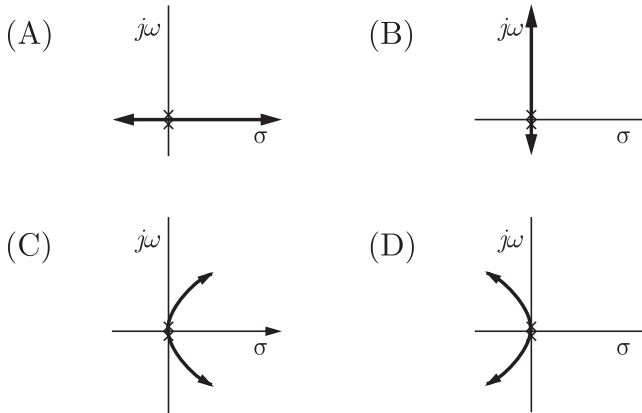

**MCQ 6.64**

The transfer function of the system described by

$$\frac{d^2 y}{dt^2} + \frac{dy}{dt} = \frac{du}{dt} + 2u$$

with  $u$  as input and  $y$  as output is

- (A)  $\frac{(s+2)}{(s^2+s)}$                       (B)  $\frac{(s+1)}{(s^2+s)}$   
(C)  $\frac{2}{(s^2+s)}$                       (D)  $\frac{2s}{(s^2+s)}$

**MCQ 6.65**

For the system

$$\dot{\mathbf{X}} = \begin{bmatrix} 2 & 0 \\ 0 & 4 \end{bmatrix} \mathbf{X} + \begin{bmatrix} 1 \\ 1 \end{bmatrix} \mathbf{u}; \mathbf{Y} = [4 \ 0] \mathbf{X},$$

with  $u$  as unit impulse and with zero initial state, the output  $y$ , becomes

- (A)  $2e^{2t}$                       (B)  $4e^{2t}$   
(C)  $2e^{4t}$                       (D)  $4e^{4t}$



**Common Data Question Q.69-71\*.**

The open loop transfer function of a unity feedback system is given by

$$G(s) = \frac{2(s + \alpha)}{s(s + 2)(s + 10)}$$

**MCQ 6.69**

Angles of asymptotes are

- (A)  $60^\circ, 120^\circ, 300^\circ$                       (B)  $60^\circ, 180^\circ, 300^\circ$   
(C)  $90^\circ, 270^\circ, 360^\circ$                       (D)  $90^\circ, 180^\circ, 270^\circ$

**MCQ 6.70**

Intercepts of asymptotes at the real axis is

- (A)  $-6$     (B)  $-\frac{10}{3}$   
(C)  $-4$     (D)  $-8$

**MCQ 6.71**

Break away points are

- (A)  $-1.056, -3.471$                               (B)  $-2.112, -6.9433$   
(C)  $-1.056, -6.9433$                               (D)  $1.056, -6.9433$

**YEAR 2001**

**ONE MARK**

**MCQ 6.72**

The polar plot of a type-1, 3-pole, open-loop system is shown in Figure The closed-loop system is

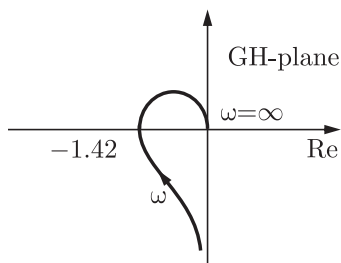

- (A) always stable  
(B) marginally stable

**Common Data Question Q.75-78\*.**

A unity feedback system has an open-loop transfer function of

$$G(s) = \frac{10000}{s(s+10)^2}$$

**MCQ 6.75**

Determine the magnitude of  $G(j\omega)$  in dB at an angular frequency of  $\omega = 20$  rad/sec.

- (A) 1 dB (B) 0 dB  
(C) -2 dB (D) 10 dB

**MCQ 6.76**

The phase margin in degrees is

- (A)  $90^\circ$  (B)  $36.86^\circ$   
(C)  $-36.86^\circ$  (D)  $-90^\circ$

**MCQ 6.77**

The gain margin in dB is

- (A) 13.97 dB (B) 6.02 dB  
(C) -13.97 dB (D) None of these

**MCQ 6.78**

The system is

- (A) Stable (B) Un-stable  
(C) Marginally stable (D) can not determined

**MCQ 6.79\***

For the given characteristic equation

$$s^3 + s^2 + Ks + K = 0$$

The root locus of the system as  $K$  varies from zero to infinity is

**Chap 6  
CONTROL SYSTEMS**

**NOTES**

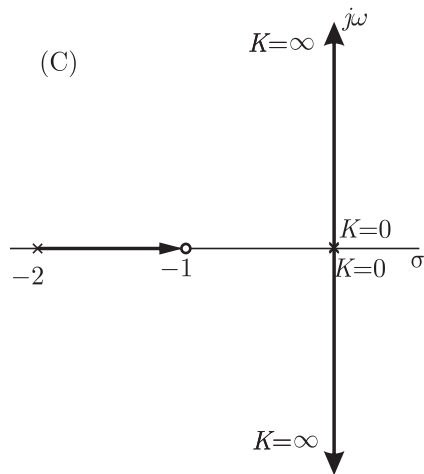
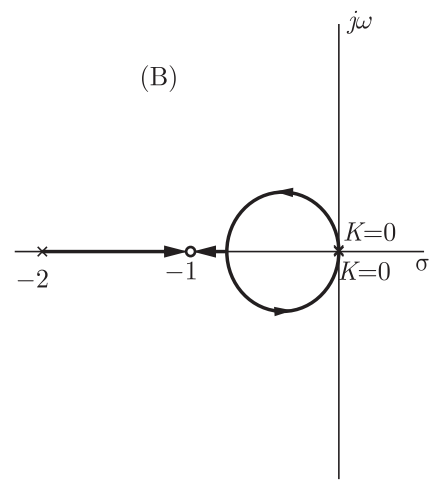
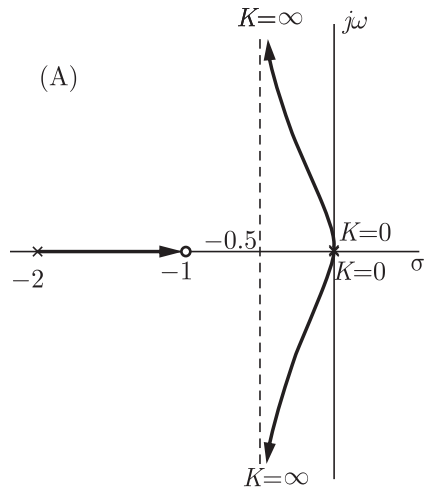

(D) none of these

\*\*\*\*\*



## SOLUTION

### SOL 6.1

Given  $G(s) = \frac{1}{s(s+1)(s+2)}$

$$G(j\omega) = \frac{1}{j\omega(j\omega+1)(j\omega+2)}$$

$$|G(j\omega)| = \frac{1}{\omega\sqrt{\omega^2+1}\sqrt{\omega^2+4}}$$

$$\angle G(j\omega) = -90^\circ - \tan^{-1}(\omega) - \tan^{-1}(\omega/2)$$

In nyquist plot

For  $\omega = 0$ ,  $|G(j\omega)| = \infty$

$$\angle G(j\omega) = -90^\circ$$

For  $\omega = \infty$ ,  $|G(j\omega)| = 0$

$$\begin{aligned}\angle G(j\omega) &= -90^\circ - 90^\circ - 90^\circ \\ &= -270^\circ\end{aligned}$$

Intersection at real axis

$$\begin{aligned}G(j\omega) &= \frac{1}{j\omega(j\omega+1)(j\omega+2)} \\ &= \frac{1}{j\omega(-\omega^2 + j3\omega + 2)} \\ &= \frac{1}{-3\omega^2 + j\omega(2 - \omega^2)} \times \frac{-3\omega^2 - j\omega(2 - \omega^2)}{-3\omega^2 - j\omega(2 - \omega^2)} \\ &= \frac{-3\omega^2 - j\omega(2 - \omega^2)}{9\omega^4 + \omega^2(2 - \omega^2)^2} \\ &= \frac{-3\omega^2}{9\omega^4 + \omega^2(2 - \omega^2)^2} - \frac{j\omega(2 - \omega^2)}{9\omega^4 + \omega^2(2 - \omega^2)^2}\end{aligned}$$

At real axis

$$\text{Im}[G(j\omega)] = 0$$

So,  $\frac{\omega(2 - \omega^2)}{9\omega^4 + \omega^2(2 - \omega^2)} = 0$

$$2 - \omega^2 = 0 \Rightarrow \omega = \sqrt{2} \text{ rad/sec}$$

At  $\omega = \sqrt{2}$  rad/sec, magnitude response is

$$|G(j\omega)|_{\text{at } \omega=\sqrt{2}} = \frac{1}{\sqrt{2}\sqrt{2+1}\sqrt{2+4}} = \frac{1}{6} < \frac{3}{4}$$

Hence (A) is correct option.

**SOL 6.2**

Stability :

Eigen value of the system are calculated as

$$\begin{aligned}
 |A - \lambda I| &= 0 \\
 A - \lambda I &= \begin{bmatrix} -1 & 2 \\ 0 & 2 \end{bmatrix} - \begin{bmatrix} \lambda & 0 \\ 0 & \lambda \end{bmatrix} \\
 &= \begin{bmatrix} -1 - \lambda & 2 \\ 0 & 2 - \lambda \end{bmatrix} \\
 |A - \lambda I| &= (-1 - \lambda)(2 - \lambda) - 2 \times 0 = 0 \\
 \Rightarrow \lambda_1, \lambda_2 &= -1, 2
 \end{aligned}$$

Since eigen values of the system are of opposite signs, so it is unstable

Controllability :

$$\begin{aligned}
 A &= \begin{bmatrix} -1 & 2 \\ 0 & 2 \end{bmatrix}, B = \begin{bmatrix} 0 \\ 1 \end{bmatrix} \\
 AB &= \begin{bmatrix} 2 \\ 2 \end{bmatrix} \\
 [B: AB] &= \begin{bmatrix} 0 & 2 \\ 1 & 2 \end{bmatrix} \\
 [B: AB] &\neq 0
 \end{aligned}$$

So it is controllable.

Hence (C) is correct option.

**SOL 6.3**

Given characteristic equation

$$s(s+1)(s+3) + K(s+2) = 0; \quad K > 0$$

$$s(s^2 + 4s + 3) + K(s+2) = 0$$

$$s^3 + 4s^2 + (3 + K)s + 2K = 0$$

From Routh's tabulation method

$s^3$	1	$3 + K$
$s^2$	4	$2K$
$s^1$	$\frac{4(3 + K) - 2K(1)}{4} = \frac{12 + 2K}{4} > 0$	
$s^0$	$2K$	

There is no sign change in the first column of routh table, so no root is lying in right half of  $s$ -plane.

**NOTES**

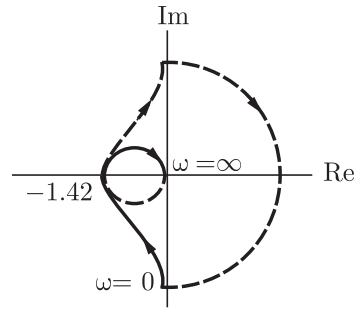

Here  $N = -2$  ( $\because$  encirclement is in clockwise direction)

$P = 0$  ( $\because$  system is stable)

So,  $Z = 0 - (-2)$

$Z = 2$ , System is unstable with 2-poles on RH of  $s$ -plane.

Hence (D) is correct option.

**SOL 6.6**

Given Routh's tabulation.

$s^3$	2	2
$s^2$	4	4
$s^1$	0	0

So the auxiliary equation is given by,

$$4s^2 + 4 = 0$$

$$s^2 = -1$$

$$s = \pm j$$

From table we have characteristic equation as

$$2s^3 + 2s + 4s^2 + 4 = 0$$

$$s^3 + s + 2s^2 + 2 = 0$$

$$s(s^2 + 1) + 2(s^2 + 1) = 0$$

$$(s + 2)(s^2 + 1) = 0$$

$$s = -2, s = \pm j$$

Hence (D) is correct option.

**SOL 6.7**

Since initial slope of the bode plot is  $-40$  dB/decade, so no. of poles at origin is 2.

Transfer function can be written in following steps:

1. Slope changes from  $-40$  dB/dec. to  $-60$  dB/dec. at  $\omega_1 = 2$  rad/sec., so at  $\omega_1$  there is a pole in the transfer function.

2. Slope changes from  $-60$  dB/dec to  $-40$  dB/dec at  $\omega_2 = 5$  rad/sec., so at this frequency there is a zero lying in the system function.
3. The slope changes from  $-40$  dB/dec to  $-60$  dB/dec at  $\omega_3 = 25$  rad/sec, so there is a pole in the system at this frequency.

Transfer function

$$T(s) = \frac{K(s+5)}{s^2(s+2)(s+25)}$$

Constant term can be obtained as.

$$T(j\omega) \Big|_{\omega=0.1} = 80$$

So,  $80 = 20 \log \frac{K(5)}{(0.1)^2 \times 50}$

$$K = 1000$$

therefore, the transfer function is

$$T(s) = \frac{1000(s+5)}{s^2(s+2)(s+25)}$$

Hence (B) is correct option.

**SOL 6.8**

From the figure we can see that steady state error for given system is

$$e_{ss} = 1 - 0.75 = 0.25$$

Steady state error for unity feed back system is given by

$$\begin{aligned} e_{ss} &= \lim_{s \rightarrow 0} \left[ \frac{sR(s)}{1+G(s)} \right] \\ &= \lim_{s \rightarrow 0} \left[ \frac{s\left(\frac{1}{s}\right)}{1 + \frac{K}{(s+1)(s+2)}} \right]; R(s) = \frac{1}{s} \text{ (unit step input)} \\ &= \frac{1}{1 + \frac{K}{2}} \\ &= \frac{2}{2+K} \end{aligned}$$

So,  $e_{ss} = \frac{2}{2+K} = 0.25$

$$2 = 0.5 + 0.25K$$

$$K = \frac{1.5}{0.25} = 6$$

Hence (D) is correct option.

**NOTES**

**SOL 6.9**

Open loop transfer function of the figure is given by,

$$G(s) = \frac{e^{-0.1s}}{s}$$

$$G(j\omega) = \frac{e^{-j0.1\omega}}{j\omega}$$

Phase cross over frequency can be calculated as,

$$\angle G(j\omega_p) = -180^\circ$$

$$\left(-0.1\omega_p \times \frac{180}{\pi}\right) - 90^\circ = -180^\circ$$

$$0.1\omega_p \times \frac{180}{\pi} = 90^\circ$$

$$0.1\omega_p = \frac{90^\circ \times \pi}{180^\circ}$$

$$\omega_p = 15.7 \text{ rad/sec}$$

$$\begin{aligned} \text{So the gain margin (dB)} &= 20 \log \left( \frac{1}{|G(j\omega_p)|} \right) \\ &= 20 \log \left[ \frac{1}{\left(\frac{1}{15.7}\right)} \right] \\ &= 20 \log 15.7 \\ &= 23.9 \text{ dB} \end{aligned}$$

Hence (D) is correct option.

**SOL 6.10**

Given system equations

$$\frac{dx_1(t)}{dt} = -3x_1(t) + x_2(t) + 2u(t)$$

$$\frac{dx_2(t)}{dt} = -2x_2(t) + u(t)$$

$$y(t) = x_1(t)$$

Taking Laplace transform on both sides of equations.

$$\begin{aligned} sX_1(s) &= -3X_1(s) + X_2(s) + 2U(s) \\ (s+3)X_1(s) &= X_2(s) + 2U(s) \end{aligned} \quad \dots(1)$$

Similarly

$$\begin{aligned} sX_2(s) &= -2X_2(s) + U(s) \\ (s+2)X_2(s) &= U(s) \end{aligned} \quad \dots(2)$$

From equation (1) & (2)

$$(s+3)X_1(s) = \frac{U(s)}{s+2} + 2U(s)$$

**NOTES**

**SOL 6.17**

Given transfer function is

$$H(s) = \frac{100}{s^2 + 20s + 100}$$

Characteristic equation of the system is given by

$$s^2 + 20s + 100 = 0$$

$$\omega_n^2 = 100 \Rightarrow \omega_n = 10 \text{ rad/sec.}$$

$$2\xi\omega_n = 20$$

or 
$$\xi = \frac{20}{2 \times 10} = 1$$

( $\xi = 1$ ) so system is critically damped.

Hence (C) is correct option.

**SOL 6.18**

State space equation of the system is given by,

$$\dot{\mathbf{X}} = \mathbf{A}\mathbf{X} + \mathbf{B}u$$

$$\mathbf{Y} = \mathbf{C}\mathbf{X}$$

Taking Laplace transform on both sides of the equations.

$$s\mathbf{X}(s) = \mathbf{A}\mathbf{X}(s) + \mathbf{B}U(s)$$

$$(sI - \mathbf{A})\mathbf{X}(s) = \mathbf{B}U(s)$$

$$\mathbf{X}(s) = (sI - \mathbf{A})^{-1}\mathbf{B}U(s)$$

$$\therefore \mathbf{Y}(s) = \mathbf{C}\mathbf{X}(s)$$

So

$$\mathbf{Y}(s) = \mathbf{C}(sI - \mathbf{A})^{-1}\mathbf{B}U(s)$$

$$\text{T.F} = \frac{\mathbf{Y}(s)}{U(s)} = \mathbf{C}(sI - \mathbf{A})^{-1}\mathbf{B}$$

$$(sI - \mathbf{A}) = \begin{bmatrix} s & 0 \\ 0 & s \end{bmatrix} - \begin{bmatrix} 0 & 1 \\ 0 & -2 \end{bmatrix} = \begin{bmatrix} s & -1 \\ 0 & s+2 \end{bmatrix}$$

$$(sI - \mathbf{A})^{-1} = \frac{1}{s(s+2)} \begin{bmatrix} s+2 & 1 \\ 0 & s \end{bmatrix}$$

$$= \begin{bmatrix} \frac{1}{s} & \frac{1}{s(s+2)} \\ 0 & \frac{1}{(s+2)} \end{bmatrix}$$

Transfer function

$$\begin{aligned} G(s) &= \mathbf{C}(sI - \mathbf{A})^{-1}\mathbf{B} = \begin{bmatrix} 1 & 0 \end{bmatrix} \begin{bmatrix} \frac{1}{s} & \frac{1}{s(s+2)} \\ 0 & \frac{1}{(s+2)} \end{bmatrix} \begin{bmatrix} 0 \\ 1 \end{bmatrix} = \begin{bmatrix} 1 & 0 \end{bmatrix} \begin{bmatrix} \frac{1}{s(s+2)} \\ \frac{1}{(s+2)} \end{bmatrix} \\ &= \frac{1}{s(s+2)} \end{aligned}$$

Hence (D) is correct option.

**SOL 6.19**

Steady state error is given by,

$$e_{ss} = \lim_{s \rightarrow 0} \left[ \frac{sR(s)}{1 + G(s)H(s)} \right]$$

Here  $R(s) = \mathcal{L}[r(t)] = \frac{1}{s}$  (Unit step input)

$$G(s) = \frac{1}{s(s+2)}$$

$H(s) = 1$  (Unity feed back)

So,

$$e_{ss} = \lim_{s \rightarrow 0} \left[ \frac{s \left( \frac{1}{s} \right)}{1 + \frac{1}{s(s+2)}} \right]$$

$$= \lim_{s \rightarrow 0} \left[ \frac{s(s+2)}{s(s+2) + 1} \right]$$

$$= 0$$

Hence (A) is correct option.

**SOL 6.20**

For input  $u_1$ , the system is ( $u_2 = 0$ )

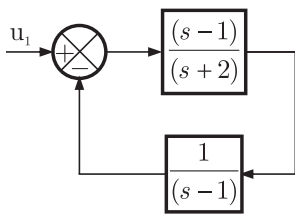

System response is

$$H_1(s) = \frac{\frac{(s-1)}{(s+2)}}{1 + \frac{(s-1)}{(s+2)} \frac{1}{(s-1)}} = \frac{(s-1)}{(s+3)}$$

Poles of the system is lying at  $s = -3$  (negative  $s$ -plane) so this is stable.

For input  $u_2$  the system is ( $u_1 = 0$ )

**SOL 6.22**

Let response of the un-compensated system is

$$H_{UC}(s) = \frac{900}{s(s+1)(s+9)}$$

Response of compensated system.

$$H_C(s) = \frac{900}{s(s+1)(s+9)} G_C(s)$$

Where  $G_C(s) \rightarrow$  Response of compensator

Given that gain-crossover frequency of compensated system is same as phase crossover frequency of un-compensated system

So,

$$\begin{aligned} (\omega_p)_{\text{compensated}} &= (\omega_p)_{\text{uncompensated}} \\ -180^\circ &= \angle H_{UC}(j\omega_p) \\ -180^\circ &= -90^\circ - \tan^{-1}(\omega_p) - \tan^{-1}\left(\frac{\omega_p}{9}\right) \end{aligned}$$

$$90^\circ = \tan^{-1}\left(\frac{\omega_p + \frac{\omega_p}{9}}{1 - \frac{\omega_p^2}{9}}\right)$$

$$1 - \frac{\omega_p^2}{9} = 0$$

$$\omega_p = 3 \text{ rad/sec.}$$

So,

$$(\omega_g)_{\text{compensated}} = 3 \text{ rad/sec.}$$

At this frequency phase margin of compensated system is

$$\begin{aligned} \phi_{PM} &= 180^\circ + \angle H_C(j\omega_g) \\ 45^\circ &= 180^\circ - 90^\circ - \tan^{-1}(\omega_g) - \tan^{-1}(\omega_g/9) + \angle G_C(j\omega_g) \end{aligned}$$

$$45^\circ = 180^\circ - 90^\circ - \tan^{-1}(3) - \tan^{-1}(1/3) + \angle G_C(j\omega_g)$$

$$45^\circ = 90^\circ - \tan^{-1}\left[\frac{3 + \frac{1}{3}}{1 - 3\left(\frac{1}{3}\right)}\right] + \angle G_C(j\omega_g)$$

$$45^\circ = 90^\circ - 90^\circ + \angle G_C(j\omega_g)$$

$$\angle G_C(j\omega_g) = 45^\circ$$

The gain cross over frequency of compensated system is lower than un-compensated system, so we may use lag-lead compensator.

At gain cross over frequency gain of compensated system is unity so.

$$|H_C(j\omega_g)| = 1$$



**NOTES**

$$\frac{900|G_C(j\omega_g)|}{\omega_g \sqrt{\omega_g^2 + 1} \sqrt{\omega_g^2 + 81}} = 1$$

$$|G_C(j\omega_g)| = \frac{3\sqrt{9+1}\sqrt{9+81}}{900}$$

$$= \frac{3 \times 30}{900} = \frac{1}{10}$$

$$\text{in dB } |G_C(\omega_g)| = 20 \log\left(\frac{1}{10}\right)$$

$$= -20 \text{ dB (attenuation)}$$

Hence (D) is correct option.

**SOL 6.23**

Characteristic equation for the given system,

$$1 + \frac{K(s+3)}{(s+8)^2} = 0$$

$$(s+8)^2 + K(s+3) = 0$$

$$s^2 + (16+K)s + (64+3K) = 0$$

By applying Routh's criteria.

$s^2$	1	$64 + 3K$
$s^1$	$16 + K$	0
$s^0$	$64 + 3K$	

For system to be oscillatory

$$16 + K = 0 \Rightarrow K = -16$$

Auxiliary equation  $A(s) = s^2 + (64 + 3K) = 0$

$$\Rightarrow s^2 + 64 + 3 \times (-16) = 0$$

$$s^2 + 64 - 48 = 0$$

$$s^2 = -16 \Rightarrow j\omega = 4j$$

$$\omega = 4 \text{ rad/sec}$$

Hence (B) is correct option.

**SOL 6.24**

From the given block diagram we can obtain signal flow graph of the system. Transfer function from the signal flow graph is written as

**NOTES**

$$= \frac{K_i}{K_i} = 1$$

Hence (A) is correct option.

System response of the given circuit can be obtained as.

$$H(s) = \frac{e_0(s)}{e_i(s)} = \frac{\left(\frac{1}{Cs}\right)}{\left(R + Ls + \frac{1}{Cs}\right)}$$

$$H(s) = \frac{1}{LCs^2 + RCs + 1}$$

$$H(s) = \frac{\left(\frac{1}{LC}\right)}{s^2 + \frac{R}{L}s + \frac{1}{LC}}$$

Characteristic equation is given by,

$$s^2 + \frac{R}{L}s + \frac{1}{LC} = 0$$

Here natural frequency  $\omega_n = \frac{1}{\sqrt{LC}}$

$$2\xi\omega_n = \frac{R}{L}$$

Damping ratio  $\xi = \frac{R}{2L}\sqrt{LC}$

$$\xi = \frac{R}{2}\sqrt{\frac{C}{L}}$$

Here

$$\xi = \frac{10}{2} \sqrt{\frac{1 \times 10^{-3}}{10 \times 10^{-6}}} = 0.5 \text{ (under damped)}$$

So peak overshoot is given by

$$\% \text{ peak overshoot} = e^{\frac{-\pi\xi}{\sqrt{1-\xi^2}}} \times 100$$

$$= e^{\frac{-\pi \times 0.5}{\sqrt{1-(0.5)^2}}} \times 100 = 16\%$$

Hence (C) is correct option.

**SOL 6.26**

Hence () is correct option.

**SOL 6.27**

In standard form for a characteristic equation give as

$$s^n + a_{n-1}s^{n-1} + \dots + a_1s + a_0 = 0$$

**SOL 6.30**

Closed loop transfer function of the given system is,

$$T(s) = \frac{s^2 + 4}{(s + 1)(s + 4)}$$

$$T(j\omega) = \frac{(j\omega)^2 + 4}{(j\omega + 1)(j\omega + 4)}$$

If system output is zero

$$|T(j\omega)| = \frac{|4 - \omega^2|}{|(j\omega + 1)(j\omega + 4)|} = 0$$

$$4 - \omega^2 = 0$$

$$\omega^2 = 4$$

$$\Rightarrow \omega = 2 \text{ rad/sec}$$

Hence (C) is correct option.

**SOL 6.31**

From the given plot we can see that centroid  $C$  (point of intersection) where asymptotes intersect on real axis) is 0

So for option (a)

$$G(s) = \frac{K}{s^3}$$

$$\text{Centroid} = \frac{\sum \text{Poles} - \sum \text{Zeros}}{n - m} = \frac{0 - 0}{3 - 0} = 0$$

Hence (A) is correct option.

**SOL 6.32**

Open loop transfer function is.

$$G(s) = \frac{(s + 1)}{s^2}$$

$$G(j\omega) = \frac{j\omega + 1}{-\omega^2}$$

Phase crossover frequency can be calculated as.

$$\angle G(j\omega_p) = -180^\circ$$

$$\tan^{-1}(\omega_p) = -180^\circ$$

$$\omega_p = 0$$

Gain margin of the system is.

$$\text{G.M} = \frac{1}{|G(j\omega_p)|} = \frac{1}{\frac{\sqrt{\omega_p^2 + 1}}{\omega_p^2}}$$

**NOTES**

$$G.M = \frac{\omega_p^2}{\sqrt{\omega_p^2 + 1}} = 0$$

Hence (A) is correct option.

**SOL 6.33**

Characteristic equation for the given system

$$1 + G(s)H(s) = 0$$

$$1 + K \frac{(1-s)}{(1+s)} = 0$$

$$(1+s) + K(1-s) = 0$$

$$s(1-K) + (1+K) = 0$$

For the system to be stable, coefficient of characteristic equation should be of same sign.

$$1 - K > 0, K + 1 > 0$$

$$K < 1, K > -1$$

$$-1 < K < 1$$

$$|K| < 1$$

Hence (C) is correct option.

**SOL 6.34**

In the given block diagram

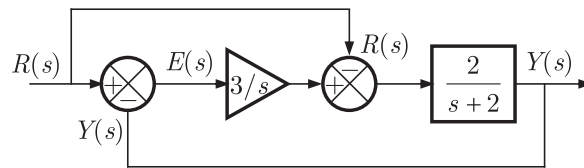

Steady state error is given as

$$e_{ss} = \lim_{s \rightarrow 0} sE(s)$$

$$E(s) = R(s) - Y(s)$$

$Y(s)$  can be written as

$$Y(s) = \left[ \{R(s) - Y(s)\} \frac{3}{s} - R(s) \right] \frac{2}{s+2}$$

$$Y(s) = R(s) \left[ \frac{6}{s(s+2)} - \frac{2}{s+2} \right] - Y(s) \left[ \frac{6}{s(s+2)} \right]$$

$$Y(s) \left[ 1 + \frac{6}{s(s+2)} \right] = R(s) \left[ \frac{6-2s}{s(s+2)} \right]$$

**NOTES**

Phase margin of the system is given as

$$\phi_{PM} = 60^\circ = 180^\circ + \angle G(j\omega_g) H(j\omega_g)$$

Where  $\omega_g \rightarrow$  gain cross over frequency = 1 rad/sec

So,

$$60^\circ = 180^\circ + \tan^{-1}\left(\frac{0.366\omega_g}{K}\right) - 90^\circ - \tan^{-1}(\omega_g)$$

$$= 90^\circ + \tan^{-1}\left(\frac{0.366}{K}\right) - \tan^{-1}(1)$$

$$= 90^\circ - 45^\circ + \tan^{-1}\left(\frac{0.366}{K}\right)$$

$$15^\circ = \tan^{-1}\left(\frac{0.366}{K}\right)$$

$$\frac{0.366}{K} = \tan 15^\circ$$

$$K = \frac{0.366}{0.267} = 1.366$$

Hence (C) is correct option.

**SOL 6.37**

Given state equation.

$$\dot{\mathbf{X}}(t) = \begin{bmatrix} 0 & 1 \\ 0 & -3 \end{bmatrix} \mathbf{X}(t) + \begin{bmatrix} 1 \\ 0 \end{bmatrix} \mathbf{u}(t)$$

Here

$$A = \begin{bmatrix} 0 & 1 \\ 0 & -3 \end{bmatrix}, B = \begin{bmatrix} 1 \\ 0 \end{bmatrix}$$

State transition matrix is given by,

$$\phi(t) = \mathcal{L}^{-1}[(sI - A)^{-1}]$$

$$\begin{aligned} [sI - A] &= \begin{bmatrix} s & 0 \\ 0 & s \end{bmatrix} - \begin{bmatrix} 0 & 1 \\ 0 & -3 \end{bmatrix} \\ &= \begin{bmatrix} s & -1 \\ 0 & s+3 \end{bmatrix} \end{aligned}$$

$$[sI - A]^{-1} = \frac{1}{s(s+3)} \begin{bmatrix} s+3 & 1 \\ 0 & s \end{bmatrix}$$

$$= \begin{bmatrix} \frac{1}{s} & \frac{1}{s(s+3)} \\ 0 & \frac{1}{(s+3)} \end{bmatrix}$$

$$\phi(t) = \mathcal{L}^{-1}[(sI - A)^{-1}]$$

$$= \begin{bmatrix} 1 & \frac{1}{3}(1 - e^{-3t}) \\ 0 & e^{-3t} \end{bmatrix}$$

Hence (A) is correct option.

**SOL 6.38**

State transition equation is given by

$$\mathbf{X}(s) = \Phi(s) \mathbf{X}(0) + \Phi(s) B U(s)$$

Here  $\Phi(s) \rightarrow$  state transition matrix

$$\Phi(s) = \begin{bmatrix} \frac{1}{s} & \frac{1}{s(s+3)} \\ 0 & \frac{1}{(s+3)} \end{bmatrix}$$

$\mathbf{X}(0) \rightarrow$  initial condition

$$\mathbf{X}(0) = \begin{bmatrix} -1 \\ 3 \end{bmatrix}$$

$$B = \begin{bmatrix} 1 \\ 0 \end{bmatrix}$$

So

$$\mathbf{X}(s) = \begin{bmatrix} \frac{1}{s} & \frac{1}{s(s+3)} \\ 0 & \frac{1}{(s+3)} \end{bmatrix} \begin{bmatrix} -1 \\ 3 \end{bmatrix} + \begin{bmatrix} \frac{1}{s} & \frac{1}{(s+3)s} \\ 0 & \frac{1}{s+3} \end{bmatrix} \begin{bmatrix} 1 \\ 0 \end{bmatrix} \frac{1}{s}$$

$$= \begin{bmatrix} -\frac{1}{s} + \frac{3}{s(s+3)} \\ 0 + \frac{3}{s+3} \end{bmatrix} + \begin{bmatrix} \frac{1}{s} \\ 0 \end{bmatrix} \frac{1}{s}$$

$$= \begin{bmatrix} -\frac{1}{s+3} \\ \frac{3}{s+3} \end{bmatrix} + \begin{bmatrix} \frac{1}{s^2} \\ 0 \end{bmatrix}$$

$$\mathbf{X}(s) = \begin{bmatrix} \frac{1}{s^2} - \frac{1}{s+3} \\ \frac{3}{s+3} \end{bmatrix}$$

Taking inverse Laplace transform, we get state transition equation as,

$$\mathbf{X}(t) = \begin{bmatrix} t - e^{-3t} \\ 3e^{-3t} \end{bmatrix}$$

Hence (C) is correct option.

**SOL 6.42**

Given characteristic equation,

$$s^3 - 4s^2 + s + 6 = 0$$

Applying Routh's method,

$s^3$	1	1
$s^2$	-4	6
$s^1$	$\frac{-4-6}{-4} = 2.5$	0
$s^0$	6	

There are two sign changes in the first column, so no. of right half poles is 2.

$$\begin{aligned} \text{No. of roots in left half of } s\text{-plane} &= (3 - 2) \\ &= 1 \end{aligned}$$

Hence (B) is correct option.

**SOL 6.43**

Block diagram of the system is given as.

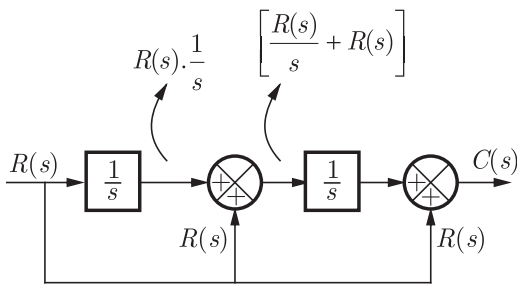

From the figure we can see that

$$C(s) = \left[ R(s) \frac{1}{s} + R(s) \right] \frac{1}{s} + R(s)$$

$$C(s) = R(s) \left[ \frac{1}{s^2} + \frac{1}{s} + 1 \right]$$

$$\frac{C(s)}{R(s)} = \frac{1 + s + s^2}{s^2}$$

Hence (B) is correct option.

**NOTES**

**SOL 6.44**

Characteristic equation is given by,

$$|sI - A| = 0$$

$$(sI - A) = \begin{bmatrix} s & 0 \\ 0 & s \end{bmatrix} - \begin{bmatrix} 0 & 2 \\ 2 & 0 \end{bmatrix}$$

$$(sI - A) = \begin{bmatrix} s & -2 \\ -2 & s \end{bmatrix}$$

$$|sI - A| = s^2 - 4$$

$$= 0$$

$$s_1, s_2 = \pm 2$$

Hence (A) is correct option

**SOL 6.45**

For the given system, characteristic equation can be written as,

$$1 + \frac{K}{s(s+2)}(1 + sP) = 0$$

$$s(s+2) + K(1 + sP) = 0$$

$$s^2 + s(2 + KP) + K = 0$$

From the equation.

$$\omega_n = \sqrt{K} = 5 \text{ rad/sec (given)}$$

So,  $K = 25$

and  $2\xi\omega_n = 2 + KP$

$$2 \times 0.7 \times 5 = 2 + 25P$$

or  $P = 0.2$

so  $K = 25, P = 0.2$

Hence (D) is correct option.

**SOL 6.46**

Unit - impulse response of the system is given as,

$$c(t) = 12.5e^{-6t} \sin 8t, t \geq 0$$

So transfer function of the system.

$$H(s) = \mathcal{L}[c(t)] = \frac{12.5 \times 8}{(s+6)^2 + (8)^2}$$

$$H(s) = \frac{100}{s^2 + 12s + 100}$$



**SOL 6.50**

Transfer function of lead compensator is given by.

$$H(s) = \frac{K\left(1 + \frac{s}{a}\right)}{\left(1 + \frac{s}{b}\right)}$$

$$H(j\omega) = K \left[ \frac{1 + j\left(\frac{\omega}{a}\right)}{1 + j\left(\frac{\omega}{b}\right)} \right]$$

So, phase response of the compensator is.

$$\begin{aligned} \theta_h(\omega) &= \tan^{-1}\left(\frac{\omega}{a}\right) - \tan^{-1}\left(\frac{\omega}{b}\right) \\ &= \tan^{-1}\left(\frac{\frac{\omega}{a} - \frac{\omega}{b}}{1 + \frac{\omega^2}{ab}}\right) = \tan^{-1}\left[\frac{\omega(b-a)}{ab + \omega^2}\right] \end{aligned}$$

$\theta_h$  should be positive for phase lead compensation

So, 
$$\theta_h(\omega) = \tan^{-1}\left[\frac{\omega(b-a)}{ab + \omega^2}\right] > 0$$

$$b > a$$

Hence (A) is correct option

**SOL 6.51**

Since there is no external input, so state is given by

$$\mathbf{X}(t) = \phi(t) \mathbf{X}(0)$$

$\phi(t)$  → state transition matrix

$\mathbf{X}[0]$  → initial condition

So 
$$x(t) = \begin{bmatrix} e^{-2t} & 0 \\ 0 & e^{-t} \end{bmatrix} \begin{bmatrix} 2 \\ 3 \end{bmatrix}$$

$$x(t) = \begin{bmatrix} 2e^{-2t} \\ 3e^{-t} \end{bmatrix}$$

At  $t = 1$ , state of the system

$$x(t)|_{t=1} = \begin{bmatrix} 2e^{-2} \\ 2e^{-1} \end{bmatrix} = \begin{bmatrix} 0.271 \\ 1.100 \end{bmatrix}$$

Hence (A) is correct option.

So

$$e_{ss} = \lim_{s \rightarrow 0} \frac{s \left( \frac{1}{s} \right)}{1 + \frac{45}{(s+15)(s+1)}}$$

$$= \frac{15}{15+45} = \frac{15}{60}$$

$$\%e_{ss} = \frac{15}{60} \times 100 = 25\%$$

Hence (A) is correct option.

**SOL 6.54**

Characteristic equation is given by

$$1 + G(s)H(s) = 0$$

Here  $H(s) = 1$  (unity feedback)

$$G(s) = \left( \frac{3}{s+15} \right) \left( \frac{15}{s+1} \right)$$

So,  $1 + \left( \frac{3}{s+15} \right) \left( \frac{15}{s+1} \right) = 0$

$$(s+15)(s+1) + 45 = 0$$

$$s^2 + 16s + 60 = 0$$

$$(s+6)(s+10) = 0$$

$$s = -6, -10$$

Hence (C) is correct option.

**SOL 6.55**

Given equation can be written as,

$$\frac{d^2\omega}{dt^2} = -\frac{\beta}{J} \frac{d\omega}{dt} - \frac{K^2}{LJ} \omega + \frac{K}{LJ} V_a$$

Here state variables are defined as,

$$\frac{d\omega}{dt} = x_1$$

$$\omega = x_2$$

So state equation is

$$\dot{x}_1 = -\frac{B}{J} x_1 - \frac{K^2}{LJ} x_2 + \frac{K}{LJ} V_a$$

$$\dot{x}_2 = \frac{d\omega}{dt} = x_1$$

In matrix form

$$\begin{bmatrix} \dot{x}_1 \\ \dot{x}_2 \end{bmatrix} = \begin{bmatrix} -B/J & -K^2/LJ \\ 1 & 0 \end{bmatrix} \begin{bmatrix} x_1 \\ x_2 \end{bmatrix} + \begin{bmatrix} K/LJ \\ 0 \end{bmatrix} V_a$$

**NOTES**

$$\begin{bmatrix} \frac{d^2\omega}{dt^2} \\ \frac{d\omega}{dt} \end{bmatrix} = P \begin{bmatrix} d\omega \\ dt \end{bmatrix} + QV_a$$

So matrix P is

$$\begin{bmatrix} -B/J & -K^2/LJ \\ 1 & 0 \end{bmatrix}$$

Hence (A) is correct option.

**SOL 6.56**

Characteristic equation of the system is given by

$$\begin{aligned} 1 + GH &= 0 \\ 1 + \frac{K}{s(s+2)(s+4)} &= 0 \\ s(s+2)(s+4) + K &= 0 \\ s^3 + 6s^2 + 8s + K &= 0 \end{aligned}$$

Applying routh's criteria for stability

$s^3$	1	8
$s^2$	6	K
$s^1$	$\frac{K-48}{6}$	
$s^0$	K	

System becomes unstable if  $\frac{K-48}{6} = 0 \Rightarrow K = 48$   
Hence (C) is correct option.

**SOL 6.57**

The maximum error between the exact and asymptotic plot occurs at corner frequency.

Here exact gain(dB) at  $\omega = 0.5a$  is given by

$$\begin{aligned} \text{gain(dB)} \Big|_{\omega=0.5a} &= 20 \log K - 20 \log \sqrt{1 + \frac{\omega^2}{a^2}} \\ &= 20 \log K - 20 \log \left[ 1 + \frac{(0.5a)^2}{a^2} \right]^{1/2} \\ &= 20 \log K - 0.96 \end{aligned}$$

Gain(dB) calculated from asymptotic plot at  $\omega = 0.5a$  is  
=  $20 \log K$

Error in gain (dB) =  $20 \log K - (20 \log K - 0.96) \text{ dB} = 0.96 \text{ dB}$   
Similarly exact phase angle at  $\omega = 0.5a$  is.

**NOTES**

$$\begin{aligned}
 Y(s) &= \frac{2G_1G_2}{1 + (2G_1G_2)9} \\
 &= \frac{(2)\left(\frac{1}{s+3}\right)\left(\frac{1}{s+12}\right)}{1 + (2)\left(\frac{1}{s+3}\right)\left(\frac{1}{s+12}\right)(9)} \\
 &= \frac{2}{(s+3)(s+12) + 18} \\
 &= \frac{2}{s^2 + 15s + 54} \\
 &= \frac{2}{(s+9)(s+6)} \\
 &= \frac{1}{27\left(1 + \frac{s}{9}\right)\left(1 + \frac{s}{6}\right)}
 \end{aligned}$$

Hence (B) is correct option.

**SOL 6.59**

Given state equation is,

$$\dot{\mathbf{X}} = A\mathbf{X}$$

Taking laplace transform on both sides of the equation,

$$s\mathbf{X}(s) - \mathbf{X}(0) = A\mathbf{X}(s)$$

$$(sI - A)\mathbf{X}(s) = \mathbf{X}(0)$$

$$\mathbf{X}(s) = (sI - A)^{-1}\mathbf{X}(0)$$

$$= \Phi(s)\mathbf{X}(0)$$

Where  $\phi(t) = \mathcal{L}^{-1}[\Phi(s)] = \mathcal{L}^{-1}[(sI - A)^{-1}]$  is defined as state transition matrix

Hence (C) is correct option.

**SOL 6.60**

State equation of the system is given as,

$$\dot{\mathbf{X}} = \begin{bmatrix} 2 & 3 \\ 0 & 5 \end{bmatrix} \mathbf{X} + \begin{bmatrix} 1 \\ 0 \end{bmatrix} \mathbf{u}$$

Here  $A = \begin{bmatrix} 2 & 3 \\ 0 & 5 \end{bmatrix}, B = \begin{bmatrix} 1 \\ 0 \end{bmatrix}$

Check for controllability:

$$AB = \begin{bmatrix} 2 & 3 \\ 0 & 5 \end{bmatrix} \begin{bmatrix} 1 \\ 0 \end{bmatrix} = \begin{bmatrix} 2 \\ 0 \end{bmatrix}$$

$$U = [B : AB] = \begin{bmatrix} 1 & 2 \\ 0 & 0 \end{bmatrix}$$

$$|U| = (1 \times 0 - 2 \times 0) \\ = 0$$

Matrix  $U$  is singular, so the system is uncontrollable.

**Check for Stability:**

Characteristic equation of the system is obtained as,

$$|sI - A| = 0 \\ (sI - A) = \begin{bmatrix} s & 0 \\ 0 & s \end{bmatrix} - \begin{bmatrix} 2 & 3 \\ 0 & 5 \end{bmatrix} \\ = \begin{bmatrix} s-2 & -3 \\ 0 & s-5 \end{bmatrix} \\ |sI - A| = (s-2)(s-5) = 0 \\ s = 2, s = 5$$

There are two R.H.S Poles in the system so it is unstable.  
Hence (B) is correct option.

**SOL 6.61**

Given open loop transfer function,

$$G(s) = \frac{K}{s^2}, \quad \begin{array}{l} \text{no of poles} = 2 \\ \text{no of zeroes} = 0 \end{array}$$

For plotting root locus:

- (1) Poles lie at  $s_1, s_2 = 0$
- (2) So the root loci starts ( $K = 0$ ) from  $s = 0$  and  $s = 0$
- (3) As there is no open-loop zero, root loci terminates ( $K = \infty$ ) at infinity.
- (4) Angle of asymptotes is given by

$$\frac{(2q+1)180^\circ}{n-m}, \quad q = 0, 1$$

So the two asymptotes are at an angle of

$$(i) \quad \frac{(2 \times 0 + 1)180^\circ}{2} = 90^\circ$$

$$(ii) \quad \frac{(2 \times 1 + 1)180^\circ}{2} = 270^\circ$$

- (5) The asymptotes intersect on real axis at a point given by

$$x = \frac{\sum \text{Poles} - \sum \text{zeros}}{n-m} = \frac{0-0}{2} = 0$$

- (6) Break away points

$$1 + \frac{K}{s^2} = 0$$

$$K = -s^2$$

$$(sI - A)^{-1} = \frac{1}{(s-2)(s-4)} \begin{bmatrix} (s-4) & 0 \\ 0 & (s-2) \end{bmatrix}$$

$$= \begin{bmatrix} \frac{1}{(s-2)} & 0 \\ 0 & \frac{1}{(s-4)} \end{bmatrix}$$

So, 
$$\frac{Y(s)}{U(s)} = [4 \ 0] \begin{bmatrix} \frac{1}{(s-2)} & 0 \\ 0 & \frac{1}{(s-4)} \end{bmatrix} \begin{bmatrix} 1 \\ 1 \end{bmatrix}$$

$$\frac{Y(s)}{U(s)} = [4 \ 0] \begin{bmatrix} \frac{1}{(s-2)} \\ \frac{1}{(s-4)} \end{bmatrix}$$

$$\frac{Y(s)}{U(s)} = \frac{4}{(s-2)}$$

Here input is unit impulse so  $U(s) = 1$  and output

$$Y(s) = \frac{4}{(s-2)}$$

Taking inverse laplace transfer we get output

$$y(t) = 4e^{2t}$$

Hence (A) is correct option.

**SOL 6.64**

Given state equation

$$\dot{\mathbf{X}} = \begin{bmatrix} 0 & 1 & 0 & 0 \\ 0 & 0 & 1 & 0 \\ 0 & 0 & 0 & 1 \\ 0 & 0 & 0 & 1 \end{bmatrix} \mathbf{X}$$

Here

$$A = \begin{bmatrix} 0 & 1 & 0 & 0 \\ 0 & 0 & 1 & 0 \\ 0 & 0 & 0 & 1 \\ 0 & 0 & 0 & 1 \end{bmatrix}$$

Eigen value can be obtained as

$$|A - \lambda I| = 0$$

$$(A - \lambda I) = \begin{bmatrix} 0 & 1 & 0 & 0 \\ 0 & 0 & 1 & 0 \\ 0 & 0 & 0 & 1 \\ 0 & 0 & 0 & 1 \end{bmatrix} - \begin{bmatrix} \lambda & 0 & 0 & 0 \\ 0 & \lambda & 0 & 0 \\ 0 & 0 & \lambda & 0 \\ 0 & 0 & 0 & \lambda \end{bmatrix}$$

**NOTES**

$$= \begin{bmatrix} -\lambda & 1 & 0 & 0 \\ 0 & -\lambda & 1 & 0 \\ 0 & 0 & -\lambda & 1 \\ 0 & 0 & 0 & 1-\lambda \end{bmatrix}$$

$$|A - \lambda I| = \lambda^3(1 - \lambda) = 0$$

or  $\lambda_1, \lambda_2, \lambda_3 = 0, \lambda_4 = 1$

Hence (D) is correct option.

**SOL 6.65**

Input-output relationship is given as

$$\frac{d^2 y}{dt^2} + 2 \frac{dy}{dt} + 10y = 5 \frac{du}{dt} - 3u$$

Taking laplace transform on both sides with zero initial condition.

$$s^2 Y(s) + 2sY(s) + 10Y(s) = 5sU(s) - 3U(s)$$

$$(s^2 + 2s + 10) Y(s) = (5s - 3) U(s)$$

Output  $Y(s) = \frac{(5s - 3)}{(s^2 + 2s + 10)} U(s)$

With no input and with given initial conditions, output is obtained as

$$\frac{d^2 y}{dt^2} + 2 \frac{dy}{dt} + 10y = 0$$

Taking laplace transform (with initial conditions)

$$[s^2 Y(s) - sy(0) - y'(0)] + 2[sY(s) - y(0)] + 10Y(s) = 0$$

Given that  $y'(0) = -4, y(0) = 1$

$$[s^2 Y(s) - s - (-4)] + 2(s - 1) + 10Y(s) = 0$$

$$Y(s)[s^2 + 2s + 10] = (s - 2)$$

$$Y(s) = \frac{(s - 2)}{(s^2 + 2s + 10)}$$

Output in both cases are same so

$$\frac{(5s - 3)}{(s^2 + 2s + 10)} U(s) = \frac{(s - 2)}{(s^2 + 2s + 10)}$$

$$U(s) = \frac{(s - 2)}{(5s - 3)}$$

$$= \frac{1}{5} \frac{(5s - 10)}{(5s - 3)}$$

$$= \frac{1}{5} \left[ \frac{(5s - 3)}{5s - 3} - \frac{7}{(5s - 3)} \right]$$

$$\frac{d\alpha}{ds} = -\frac{1}{2}[3s^2 + 24s + 22] = 0$$

$$s_1, s_2 = -1.056, -6.9433$$

Hence (C) is correct option.

**SOL 6.70**

Hence () is correct option.

**SOL 6.71**

Given state equation

$$\dot{\mathbf{X}} = \begin{bmatrix} -3 & 1 \\ 0 & -2 \end{bmatrix} \mathbf{X}$$

Or  $\dot{\mathbf{X}} = A\mathbf{X}$ , where  $A = \begin{bmatrix} -3 & 1 \\ 0 & -2 \end{bmatrix}$

Taking Laplace transform on both sides.

$$s\mathbf{X}(s) - \mathbf{X}(0) = A\mathbf{X}(s)$$

$$\mathbf{X}(s)(sI - A) = \mathbf{X}(0)$$

$$\mathbf{X}(s) = (sI - A)^{-1} \mathbf{X}(0)$$

Steady state value of  $\mathbf{X}$  is given by

$$\begin{aligned} x_{ss} &= \lim_{s \rightarrow 0} s\mathbf{X}(s) \\ &= \lim_{s \rightarrow 0} s(sI - A)^{-1} \mathbf{X}(0) \end{aligned}$$

$$\begin{aligned} (sI - A) &= \begin{bmatrix} s & 0 \\ 0 & s \end{bmatrix} - \begin{bmatrix} -3 & 1 \\ 0 & -2 \end{bmatrix} \\ &= \begin{bmatrix} s+3 & -1 \\ 0 & s+2 \end{bmatrix} \end{aligned}$$

$$\begin{aligned} (sI - A)^{-1} &= \frac{1}{(s+3)(s+2)} \begin{bmatrix} s+2 & 1 \\ 0 & s+3 \end{bmatrix} \\ &= \begin{bmatrix} \frac{1}{(s+3)} & \frac{1}{(s+2)(s+3)} \\ 0 & \frac{1}{(s+2)} \end{bmatrix} \end{aligned}$$

So the steady state value

$$x_{ss} = \lim_{s \rightarrow 0} s \begin{bmatrix} \frac{1}{(s+3)} & \frac{1}{(s+2)(s+3)} \\ 0 & \frac{1}{(s+2)} \end{bmatrix} \begin{bmatrix} 10 \\ -10 \end{bmatrix}$$



$$= \frac{10^4}{20 \times 5 \times 10^2} = 1$$

$$\begin{aligned} \text{Magnitude in dB} &= 20 \log_{10} |G(j20)| \\ &= 20 \log_{10} 1 \\ &= 0 \text{ dB} \end{aligned}$$

Hence (B) is correct option.

Since  $|G(j\omega)| = 1$  at  $\omega = 20$  rad/sec, So this is the gain cross-over frequency

$$\omega_g = 20 \text{ rad/sec}$$

$$\text{Phase margin } \phi_{\text{PM}} = 180^\circ + \angle G(j\omega_g)$$

$$\angle G(j\omega_g) = -90^\circ - \tan^{-1} \left[ \frac{20\omega_g}{100 - \omega_g^2} \right]$$

$$\begin{aligned} \phi_{\text{PM}} &= 180 - 90^\circ - \tan^{-1} \left[ \frac{20 \times 20}{100 - (20)^2} \right] \\ &= -36.86^\circ \end{aligned}$$

Hence (C) is correct option.

**SOL 6.74**

To calculate the gain margin, first we have to obtain phase cross over frequency ( $\omega_p$ ).

At phase cross over frequency

$$\begin{aligned} \angle G(j\omega_p) &= -180^\circ \\ -90^\circ - \tan^{-1} \left[ \frac{20\omega_p}{100 - \omega_p^2} \right] &= -180^\circ \end{aligned}$$

$$\tan^{-1} \left[ \frac{20\omega_p}{100 - \omega_p^2} \right] = 90^\circ$$

$$100 - \omega_p^2 = 0 \Rightarrow \omega_p = 10 \text{ rad/sec.}$$

$$\text{Gain margin in dB} = 20 \log_{10} \left( \frac{1}{|G(j\omega_p)|} \right)$$

$$\begin{aligned} |G(j\omega_p)| &= |G(j10)| = \frac{10^4}{10\sqrt{(100 - 100)^2 + 400(10)^2}} \\ &= \frac{10^4}{10 \times 2 \times 10^2} = 5 \end{aligned}$$

$$\begin{aligned} \text{G.M.} &= 20 \log_{10} \left( \frac{1}{5} \right) \\ &= -13.97 \text{ dB} \end{aligned}$$

Hence (C) is correct option.

**NOTES**

**SOL 6.75**

Since gain margin and phase margin are negative, so the system is unstable.

Hence (B) is correct option.

**SOL 6.76**

Given characteristic equation

$$s^3 + s^2 + Ks + K = 0$$

$$1 + \frac{K(s+1)}{s^3 + s^2} = 0$$

$$1 + \frac{K(s+1)}{s^2(s+2)} = 0$$

so open loop transfer function is

$$G(s) = \frac{K(s+1)}{s^2(s+1)}$$

root-locus is obtained in following steps:

1. Root-loci starts ( $K = 0$ ) at  $s = 0$ ,  $s = 0$  and  $s = -2$
2. There is one zero at  $s = -1$ , so one of root-loci terminates at  $s = -1$  and other two terminates at infinity
3. No. of poles  $n = 3$ , no of zeros,  $m = 1$
4. Break - Away points

$$\frac{dK}{ds} = 0$$

Asymptotes meets on real axis at a point  $C$

$$C = \frac{\sum \text{poles} - \sum \text{zeros}}{n - m}$$

$$= \frac{(0 + 0 - 2) - (-1)}{3 - 1} = -0.5$$

Hence (C) is correct option.

\*\*\*\*\*

# 7

## CHAPTER

# Electrical & Electronic Measurements

YEAR 2010

ONE MARK

### MCQ 7.1

A wattmeter is connected as shown in figure. The wattmeter reads.

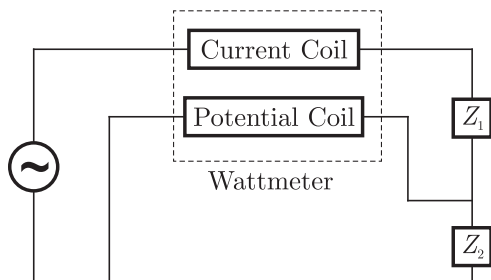

- (A) Zero always
- (B) Total power consumed by  $Z_1$  and  $Z_2$
- (C) Power consumed by  $Z_1$
- (D) Power consumed by  $Z_2$

### MCQ 7.2

An ammeter has a current range of 0-5 A, and its internal resistance is  $0.2 \Omega$ . In order to change the range to 0-25 A, we need to add a resistance of

- (A)  $0.8 \Omega$  in series with the meter
- (B)  $1.0 \Omega$  in series with the meter
- (C)  $0.04 \Omega$  in parallel with the meter
- (D)  $0.05 \Omega$  in parallel with the meter



**NOTES**

an rms-reading meter will read

- (A)  $\frac{20}{\sqrt{3}}$  (B)  $\frac{10}{\sqrt{3}}$   
 (C)  $20\sqrt{3}$  (D)  $10\sqrt{3}$

**YEAR 2008**

**ONE MARK**

**MCQ 7.9**

Two 8-bit ADCs, one of single slope integrating type and other of successive approximate type, take  $T_A$  and  $T_B$  times to convert 5 V analog input signal to equivalent digital output. If the input analog signal is reduced to 2.5 V, the approximate time taken by the two ADCs will respectively, be

- (A)  $T_A, T_B$  (B)  $T_A/2, T_B$   
 (C)  $T_A, T_B/2$  (D)  $T_A/2, T_B/2$

**YEAR 2008**

**TWO MARKS**

**MCQ 7.10**

Two sinusoidal signals  $p(\omega_1, t) = A \sin \omega_1 t$  and  $q(\omega_2 t)$  are applied to X and Y inputs of a dual channel CRO. The Lissajous figure displayed on the screen shown below :

The signal  $q(\omega_2 t)$  will be represented as

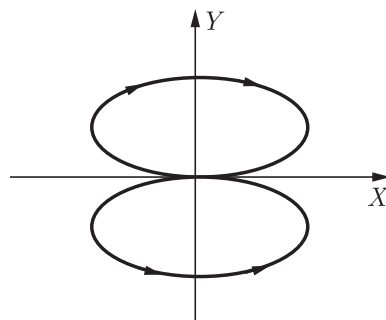

- (A)  $q(\omega_2 t) = A \sin \omega_2 t, \omega_2 = 2\omega_1$   
 (B)  $q(\omega_2 t) = A \sin \omega_2 t, \omega_2 = \omega_1/2$   
 (C)  $q(\omega_2 t) = A \cos \omega_2 t, \omega_2 = 2\omega_1$   
 (D)  $q(\omega_2 t) = A \cos \omega_2 t, \omega_2 = \omega_1/2$



**MCQ 7.13**

A bridge circuit is shown in the figure below. Which one of the sequence given below is most suitable for balancing the bridge ?

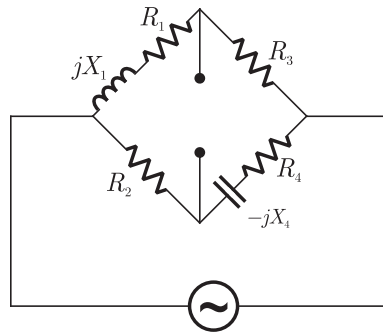

- (A) First adjust  $R_4$ , and then adjust  $R_1$
- (B) First adjust  $R_2$ , and then adjust  $R_3$
- (C) First adjust  $R_2$ , and then adjust  $R_4$
- (D) First adjust  $R_4$ , and then adjust  $R_2$

**MCQ 7.14**

The time/div and voltage/div axes of an oscilloscope have been erased. A student connects a 1 kHz, 5 V p-p square wave calibration pulse to channel-1 of the scope and observes the screen to be as shown in the upper trace of the figure. An unknown signal is connected to channel-2(lower trace) of the scope. If the time/div and V/div on both channels are the same, the amplitude (p-p) and period of the unknown signal are respectively

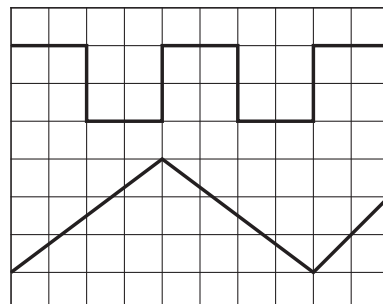





YEAR 2005

TWO MARKS

NOTES

**MCQ 7.23**

The simultaneous application of signals  $x(t)$  and  $y(t)$  to the horizontal and vertical plates, respectively, of an oscilloscope, produces a vertical figure-of-8 display. If  $P$  and  $Q$  are constants and  $x(t) = P \sin(4t + 30^\circ)$ , then  $y(t)$  is equal to

- (A)  $Q \sin(4t - 30^\circ)$                       (B)  $Q \sin(2t + 15^\circ)$   
 (C)  $Q \sin(8t + 60^\circ)$                       (D)  $Q \sin(4t + 30^\circ)$

**MCQ 7.24**

A DC ammeter has a resistance of  $0.1 \Omega$  and its current range is 0-100 A. If the range is to be extended to 0-500 A, then meter required the following shunt resistance

- (A)  $0.010 \Omega$                                       (B)  $0.011 \Omega$   
 (C)  $0.025 \Omega$                                       (D)  $1.0 \Omega$

**MCQ 7.25**

The set-up in the figure is used to measure resistance  $R$ . The ammeter and voltmeter resistances are  $0.01 \Omega$  and  $2000 \Omega$ , respectively. Their readings are 2 A and 180 V, respectively, giving a measured resistances of  $90 \Omega$ . The percentage error in the measurement is

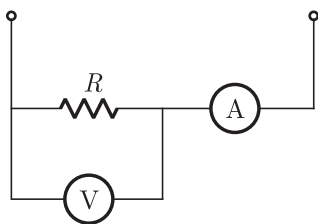

- (A) 2.25%    (B) 2.35%  
 (C) 4.5%    (D) 4.71%

**MCQ 7.26**

A 1000 V DC supply has two 1-core cables as its positive and negative leads : their insulation resistances to earth are  $4 \text{ M}\Omega$  and  $6 \text{ M}\Omega$ , respectively, as shown in the figure. A voltmeter with resistance  $50 \text{ k}\Omega$  is used to measure the insulation of the cable. When connected



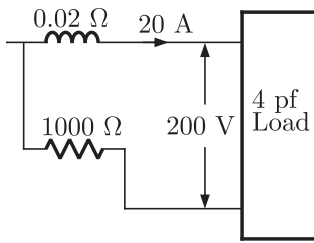

- (A) 0.4 % less  
 (B) 0.2% less  
 (C) 0.2% more  
 (D) 0.4% more

**MCQ 7.30**

A galvanometer with a full scale current of 10 mA has a resistance of 1000 Ω. The multiplying power (the ratio of measured current to galvanometer current) of 100 Ω shunt with this galvanometer is

- (A) 110  
 (B) 100  
 (C) 11  
 (D) 10

**YEAR 2004**

**TWO MARKS**

**MCQ 7.31**

A CRO probe has an impedance of 500 kΩ in parallel with a capacitance of 10 pF. The probe is used to measure the voltage between P and Q as shown in figure. The measured voltage will be

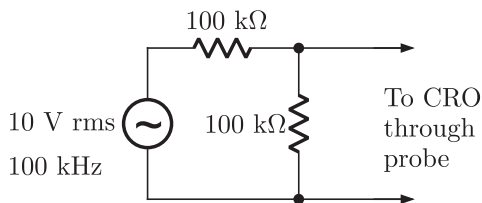

- (A) 3.53 V  
 (B) 4.37 V  
 (C) 4.54 V  
 (D) 5.00 V

**MCQ 7.32**

A moving coil of a meter has 100 turns, and a length and depth of 10 mm and 20 mm respectively. It is positioned in a uniform radial flux density of 200 mT. The coil carries a current of 50 mA. The torque on the coil is

**NOTES**

- (A)  $200 \mu\text{Nm}$  (B)  $100 \mu\text{Nm}$   
 (C)  $2 \mu\text{Nm}$  (D)  $1 \mu\text{Nm}$

**MCQ 7.33**

A dc A-h meter is rated for 15 A, 250 V. The meter constant is 14.4 A-sec/rev. The meter constant at rated voltage may be expressed as

- (A) 3750 rev/kWh (B) 3600 rev/kWh  
 (C) 1000 rev/kWh (D) 960 rev/kWh

**MCQ 7.34**

A moving iron ammeter produces a full scale torque of  $240 \mu\text{Nm}$  with a deflection of  $120^\circ$  at a current of 10 A. The rate of change of self induction ( $\mu\text{H}/\text{radian}$ ) of the instrument at full scale is

- (A)  $2.0 \mu\text{H}/\text{radian}$  (B)  $4.8 \mu\text{H}/\text{radian}$   
 (C)  $12.0 \mu\text{H}/\text{radian}$  (D)  $114.6 \mu\text{H}/\text{radian}$

**MCQ 7.35**

A single-phase load is connected between R and Y terminals of a 415 V, symmetrical, 3-phase, 4-wire system with phase sequence RYB. A wattmeter is connected in the system as shown in figure. The power factor of the load is 0.8 lagging. The wattmeter will read

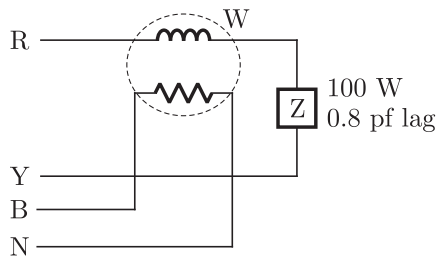

- (A)  $-795 \text{ W}$  (B)  $-597 \text{ W}$   
 (C)  $+597 \text{ W}$  (D)  $+795 \text{ W}$

**MCQ 7.36**

A 50 Hz, bar primary CT has a secondary with 500 turns. The secondary supplies 5 A current into a purely resistive burden of  $1 \Omega$ . The magnetizing ampere-turns is 200. The phase angle between the primary and second current is



Codes :

- (A) P=2, Q=3, R=6, S=5
- (B) P=2, Q=6, R=4, S=5
- (C) P=2, Q=3, R=5, S=4
- (D) P=1, Q=3, R=2, S=6

**MCQ 7.43**

A rectifier type ac voltmeter of a series resistance  $R_s$ , an ideal full-wave rectifier bridge and a PMMC instrument as shown in figure. The internal resistance of the instrument is  $100 \Omega$  and a full scale deflection is produced by a dc current of  $1 \text{ mA}$ . The value of  $R_s$  required to obtain full scale deflection with an ac voltage of  $100 \text{ V}$  (rms) applied to the input terminals is

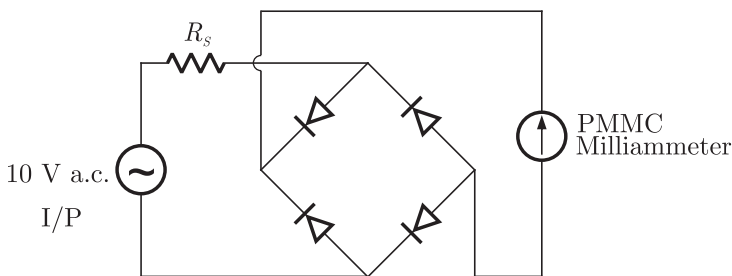

- (A)  $63.56 \Omega$
- (B)  $69.93 \Omega$
- (C)  $89.93 \Omega$
- (D)  $141.3 \text{ k}\Omega$

**MCQ 7.44**

A wattmeter reads  $400 \text{ W}$  when its current coil is connected in the R-phase and its pressure coil is connected between this phase and the neutral of a symmetrical 3-phase system supplying a balanced star connected  $0.8 \text{ p.f.}$  inductive load. This phase sequence is RYB. What will be the reading of this wattmeter if its pressure coil alone is reconnected between the B and Y phases, all other connections remaining as before ?

- (A)  $400.0$
- (B)  $519.6$
- (C)  $300.0$
- (D)  $692.8$

**NOTES**

**MCQ 7.45**

The inductance of a certain moving-iron ammeter is expressed as  $L = 10 + 3\theta - (\theta^2/4) \mu H$ , where  $\theta$  is the deflection in radians from the zero position. The control spring torque is  $25 \times 10^{-6}$  Nm/radian. The deflection of the pointer in radian when the meter carries a current of 5 A, is

- (A) 2.4 (B) 2.0  
(C) 1.2 (D) 1.0

**MCQ 7.46**

A 500A/5A, 50 Hz transformer has a bar primary. The secondary burden is a pure resistance of  $1 \Omega$  and it draws a current of 5 A. If the magnetic core requires 250 AT for magnetization, the percentage ratio error is

- (A) 10.56 (B) -10.56  
(C) 11.80 (D) -11.80

**MCQ 7.47**

The voltage-flux adjustment of a certain 1-phase 220 V induction watt-hour meter is altered so that the phase angle between the applied voltage and the flux due to it is  $85^\circ$  (instead of  $90^\circ$ ). The errors introduced in the reading of this meter when the current is 5 A at power factor of unity and 0.5 lagging are respectively

- (A) 3.8 mW, 77.4 mW (B) -3.8 mW, -77.4 mW  
(C) -4.2 W, -85.1 W (D) 4.2 W, 85.1 W

**MCQ 7.48**

Group-II represents the figures obtained on a CRO screen when the voltage signals  $V_x = V_{xm} \sin \omega t$  and  $V_y = V_{ym} \sin(\omega t + \Phi)$  are given to its X and Y plates respectively and  $\Phi$  is changed. Choose the correct value of  $\Phi$  from Group-I to match with the corresponding figure of Group-II.

Group-I

Group-II

P.  $\Phi = 0$

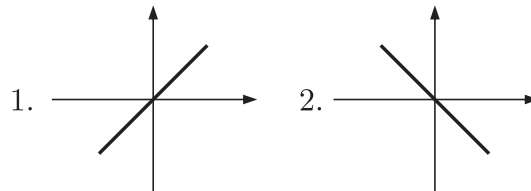

Q.  $\Phi = \pi/2$

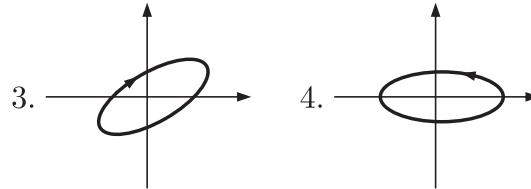

R.  $\pi < \Phi < 3\pi/2$

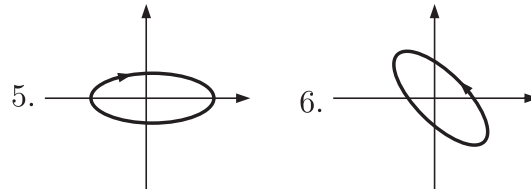

S.  $\Phi = 3\pi/2$

Codes :

- (A) P=1, Q=3, R=6, S=5
- (B) P=2, Q=6, R=4, S=5
- (C) P=2, Q=3, R=5, S=4
- (D) P=1, Q=5, R=6, S=4

**YEAR 2002**

**ONE MARK**

**MCQ 7.49**

Two in-phase, 50 Hz sinusoidal waveforms of unit amplitude are fed into channel-1 and channel-2 respectively of an oscilloscope. Assuming that the voltage scale, time scale and other settings are exactly the same for both the channels, what would be observed if the oscilloscope is operated in X-Y mode ?

- (A) A circle of unit radius
- (B) An ellipse
- (C) A parabola
- (D) A straight line inclined at  $45^\circ$  with respect to the x-axis.



- (A) 20.0  
(C) 25.0
- (B) 22.22  
(D) 50.0

**MCQ 7.54**

Resistance  $R_1$  and  $R_2$  have, respectively, nominal values of  $10\ \Omega$  and  $5\ \Omega$ , and tolerance of  $\pm 5\%$  and  $\pm 10\%$ . The range of values for the parallel combination of  $R_1$  and  $R_2$  is

- (A)  $3.077\ \Omega$  to  $3.636\ \Omega$   
(B)  $2.805\ \Omega$  to  $3.371\ \Omega$   
(C)  $3.237\ \Omega$  to  $3.678\ \Omega$   
(D)  $3.192\ \Omega$  to  $3.435\ \Omega$

\*\*\*\*\*

**NOTES**

## SOLUTIONS

### SOL 7.1

Since potential coil is applied across  $Z_2$  as shown below

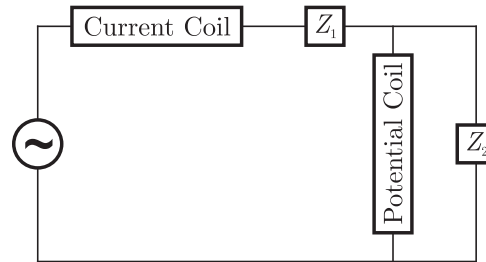

Wattmeter read power consumed by  $Z_2$   
Hence (D) is correct option.

### SOL 7.2

Given that full scale current is 5 A

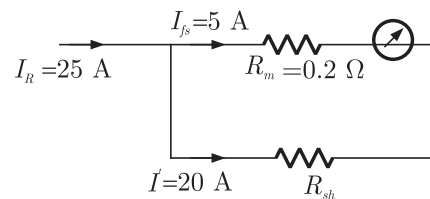

$$\begin{aligned} \text{Current in shunt } I' &= I_R - I_{fs} \\ &= 25 - 5 \\ &= 20 \text{ A} \\ 20 \times R_{sh} &= 5 \times 0.2 \\ R_{sh} &= \frac{1}{20} \\ &= .05 \Omega \end{aligned}$$

Hence (D) is correct option.

### SOL 7.3

Overall gain of the system is

$$g = \frac{100}{1 + 100\left(\frac{9}{100}\right)} = 10 \text{ (zero error)}$$

**NOTES**

$$R = \frac{R_2 R_3}{R_4}$$

similarly,

$$\frac{LR_4}{C_4} = R_2 R_3 R_4$$

$$L = R_2 R_3 C_4$$

Hence (A) is correct option.

**SOL 7.5**

Since Potential coil is connected across the load terminal, so it should be highly resistive, so that all the voltage appears across load.

Hence (B) is correct option.

**SOL 7.6**

A circle is produced when there is a  $90^\circ$  phase difference between vertical and horizontal inputs.

Hence (D) is correct option.

**SOL 7.7**

$$\text{Wattmeter reading } P = V_{PC} I_{CC}$$

$V_{PC} \rightarrow$  Voltage across potential coil.

$I_{CC} \rightarrow$  Current in current coil.

$$V_{PC} = V_{bc} = 400 \angle -120^\circ$$

$$I_{CC} = I_{ac} = \frac{400 \angle 120^\circ}{100} = 4 \angle 120^\circ$$

$$\text{Power } P = 400 \angle -120^\circ \times 4 \angle 120^\circ$$

$$= 1600 \angle 240^\circ$$

$$= 1600 \times \frac{1}{2}$$

$$= 800 \text{ Watt}$$

Hence (C) is correct option.

**SOL 7.8**

$$\text{Average value of a triangular wave } V_{av} = \frac{V_m}{3}$$

$$\text{rms value } V_{ms} = \frac{V_m}{\sqrt{3}}$$

$$\text{Given that } V_{av} = \frac{V_m}{3} = 10 \text{ V}$$

So 
$$V_{rms} = \frac{V_m}{\sqrt{3}} = \sqrt{3} V_{av} = 10\sqrt{3} \text{ V}$$

Hence (D) is correct option.

**SOL 7.9**

Conversion time does not depend on input voltage so it remains same for both type of ADCs.

Hence (A) is correct option.

**SOL 7.10**

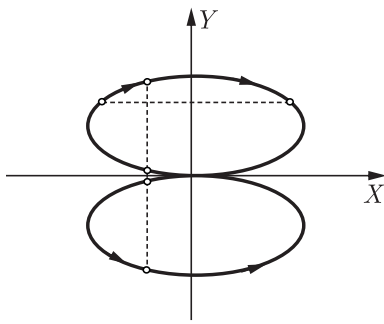

Frequency ratio 
$$\frac{f_Y}{f_X} = \frac{\text{meeting points of horizontal tangents}}{\text{meeting points of vertical tangents}}$$

$$\frac{f_Y}{f_X} = \frac{2}{4}$$

$$f_Y = \frac{1}{2}(f_X)$$

$$\omega_2 = \omega_1/2$$

Since the Lissajous figures are ellipse, so there is a phase difference of  $90^\circ$  exists between vertical and horizontal inputs.

So  $q(\omega_2 t) = A \cos \omega_2 t, \omega_2 = \omega_1/2$

Hence (D) is correct option.

**SOL 7.11**

Impedance of different branches is given as

$$Z_{AB} = 500 \Omega$$

$$\begin{aligned} Z_{BC} &= \frac{1}{j \times 2\pi \times 2 \times 10^3 \times 0.398 \mu F} + 300 \Omega \\ &\simeq (-200j + 300) \Omega \end{aligned}$$

**NOTES**

$$Z_{AD} = j \times 2\pi \times 2 \times 10^3 \times 15.91 \text{ mH} + 300 \Omega$$

$$\simeq (200j + 300) \Omega$$

To balance the bridge

$$Z_{AB}Z_{CD} = Z_{AD}Z_{BC}$$

$$500Z = (200j + 300)(-200j + 300)$$

$$500Z = 130000$$

$$Z = (260 + j0) \Omega$$

Hence (A) is correct option.

**SOL 7.12**

Since both the waveform appeared across resistor and inductor are same so the common point is B. Signal Probe  $S_1$  is connecte with A,  $S_2$  is connected with C and both the grount probes  $G_1$  and  $G_2$  are connected with common point B.

Hence (B) is correct option.

**SOL 7.13**

To balance the bridge

$$(R_1 + jX_1)(R_4 - jX_4) = R_2R_3$$

$$(R_1R_4 + X_1X_4) + j(X_1R_4 - R_1X_4) = R_2R_3$$

comparing real and imaginary parts on both sides of equations

$$R_1R_4 + X_1X_4 = R_2R_3 \quad \dots(1)$$

$$X_1R_4 - R_1X_4 = 0 \Rightarrow \frac{X_1}{X_4} = \frac{R_1}{R_4} \quad \dots(2)$$

from eq(1) and (2) it is clear that for balancing the bridge first balance  $R_4$  and then  $R_1$ .

Hence (A) is correct option.

**SOL 7.14**

From the Calibration pulse we can obtain

$$\frac{\text{Voltage}}{\text{Division}}(\Delta V) = \frac{5}{2} = 2.5 \text{ V}$$

$$\frac{\text{Time}}{\text{Division}}(\Delta T) = \frac{1 \text{ ms}}{4} = \frac{1}{4} \text{ msec}$$

So amplitude (p-p) of unknown signal is

$$V_{P-P} = \Delta V \times 5$$

$$= 2.5 \times 5 = 7.5 \text{ V}$$

$$\begin{aligned} \text{Time period } T &= \Delta T \times 8 \\ &= \frac{1}{4} \times 8 = 2 \text{ ms} \end{aligned}$$

Hence (C) is correct option.

**SOL 7.15**

Reading of wattmeter (Power) in the circuit

$$P_{av} = \frac{1}{T} \int_0^T VI dt = \text{Common area between } V-I$$

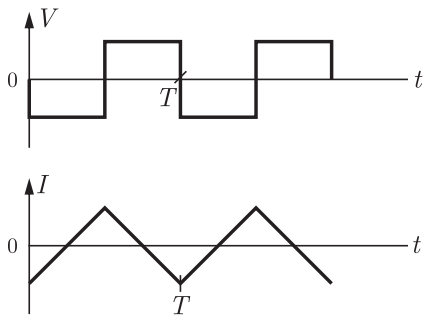

total common area = 0 (Positive and negative area are equal)

So  $P_{av} = 0$

Hence (A) is correct option.

**SOL 7.16**

PMMC instrument reads only dc value so

$$I_{\text{PMMC}} = -8 \text{ A}$$

rms meter reads rms value so

$$\begin{aligned} I_{rms} &= \sqrt{(-8)^2 + \frac{(6\sqrt{2})^2}{2}} \\ &= \sqrt{64 + 36} \\ &= 10 \text{ A} \end{aligned}$$

Moving iron instrument also reads rms value of current So

$$I_{\text{MI}} = 10 \text{ mA}$$

Reading are  $(I_{\text{PMMC}}, I_{rms}, I_{\text{MI}}) = (-8 \text{ A}, 10 \text{ A}, 10 \text{ A})$

Hence (C) is correct option.

**SOL 7.17**

$$\text{Given that } \omega = \frac{xy}{z}$$

$$\log \omega = \log x + \log y - \log z$$

**SOL 7.20**

Q-meter works on the principle of series resonance.

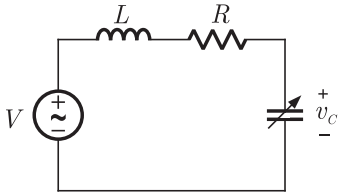

At resonance  $V_C = V_L$

$$\text{and } I = \frac{V}{R}$$

$$\text{Quality factor } Q = \frac{\omega L}{R} = \frac{1}{\omega CR}$$

$$Q = \frac{\omega L \times I}{R \times I} = \frac{V_L}{E} = \frac{V_C}{E}$$

Thus, we can obtain Q

Hence (C) is correct option.

**SOL 7.21**

PMMC instruments reads DC value only so it reads 2 V.

Option (A) is correct option.

**SOL 7.22**

$$\text{Resolution of n-bit DAC} = \frac{V_{fs}}{2^n - 1}$$

$$\text{So } 14 \text{ mv} = \frac{3.5 \text{ V}}{2^n - 1}$$

$$2^n - 1 = \frac{3.5}{14 \times 10^{-3}}$$

$$2^n - 1 = 250$$

$$2^n = 251$$

$$n = 8 \text{ bit}$$

Hence (B) is correct option.

**SOL 7.23**

We can obtain the frequency ratio as following

**NOTES**

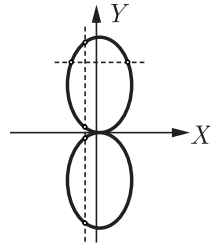

$$\frac{f_Y}{f_X} = \frac{\text{meeting points of horizontal tangents}}{\text{meeting points of vertical tangents}}$$

$$\frac{f_Y}{f_X} = \frac{2}{4}$$

$$f_Y = \frac{1}{2}f_X$$

There should exist a phase difference ( $15^\circ$ ) also to produce exact figure of-8.

Hence (B) is correct option.

**SOL 7.24**

The configuration is shown below

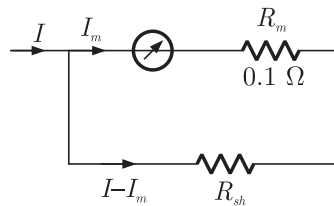

It is given that  $I_m = 100 \text{ A}$

Range is to be extended to  $0 - 500 \text{ A}$ ,

$$I = 500 \text{ A}$$

So,

$$I_m R_m = (I - I_m) R_{sh}$$

$$100 \times 0.1 = (500 - 100) R_{sh}$$

$$R_{sh} = \frac{100 \times 0.1}{400}$$

$$= 0.025 \text{ } \Omega$$

Hence (C) is correct option.



**NOTES**

**SOL 7.27**

$$\begin{aligned} \text{Total power } P &= P_1 + P_2 \\ &= 10.5 - 2.5 \\ &= 8 \text{ kW} \end{aligned}$$

$$\text{Power factor} = \cos \theta$$

Where

$$\begin{aligned} \theta &= \tan^{-1} \left[ \sqrt{3} \left( \frac{P_2 - P_1}{P_2 + P_1} \right) \right] \\ &= \tan^{-1} \left[ \sqrt{3} \times \frac{-13}{8} \right] \\ &= -70.43^\circ \end{aligned}$$

$$\text{Power factor} = \cos \theta = 0.334$$

Hence (D) is correct option.

**SOL 7.28**(check)

for the dc potentiometer  $E \propto l$

$$\text{so, } \frac{E_1}{E_2} = \frac{l_1}{l_2}$$

$$\begin{aligned} E_2 &= E_1 \left( \frac{l_1}{l_2} \right) \\ &= (1.18) \times \frac{680}{600} \\ &= 1.34 \text{ V} \end{aligned}$$

Hence (B) is correct option.

**SOL 7.29**

Let the actual voltage and current are  $I_1$  and  $V_1$  respectively, then

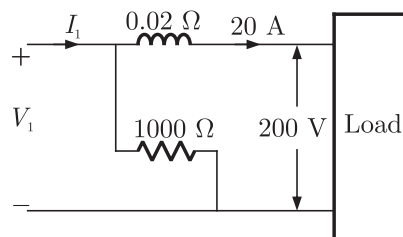

Current in CC is  $20 \text{ A}$

$$20 = I_1 \left( \frac{1000}{1000 + 0.02} \right)$$

$$I_1 = 20.0004 \text{ A} \approx 20 \text{ A}$$

$$\begin{aligned} 200 &= V_1 - .02 \times 20 \\ &= 200.40 \end{aligned}$$

Power measured  $P_m = V_1 I_1 = 20(200.40)$   
 $= 4008 \text{ W}$

Load power  $P_L = 20 \times 200 = 4000 \text{ W}$

$$\begin{aligned} \% \text{ Change} &= \frac{P_m - P_L}{P_L} = \frac{4008 - 4000}{4000} \times 100 \\ &= 0.2\% \text{ more} \end{aligned}$$

Hence (C) is correct option.

**SOL 7.30**

We have to obtain  $n = \frac{I}{I_1}$

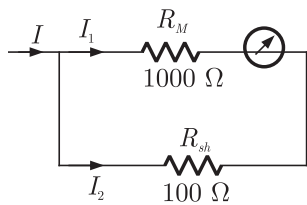

$$\frac{I_1}{I_2} = \frac{R_{sh}}{R_m} = \frac{100}{1000} = \frac{1}{10}$$

$$I_1 + I_2 = I$$

$$I_1 + 10I_1 = I$$

$$11I_1 = I$$

$$n = \frac{I}{I_1} = 11$$

Hence (C) is correct option.

**SOL 7.31**

In the following configuration

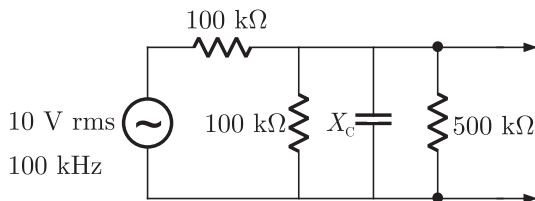

reactance  $X_c = \frac{1}{j\omega C} = \frac{1}{2\pi \times 100 \times 10^3 \times 10 \times 10^{-12}}$

**SOL 7.34**

For moving iron ameter full scale torque is given by

$$\tau_C = \frac{1}{2} I^2 \frac{dL}{d\theta}$$

$$240 \times 10^{-6} = \frac{1}{2} (10)^2 \frac{dL}{d\theta}$$

Change in inductance

$$\frac{dL}{d\theta} = 4.8 \text{ } \mu\text{H/radian}$$

Hence (B) is correct option

**SOL 7.35**

In the figure

$$V_{RY} = 415 \angle 30^\circ$$

$$V_{BN} = \frac{415}{\sqrt{3}} \angle 120^\circ$$

Current in current coil

$$I_C = \frac{V_{RY}}{Z}$$

$$= \frac{415 \angle 30^\circ}{100 \angle 36.87^\circ} \quad \therefore \text{power factor} = 0.8$$

$$= 4.15 \angle -6.87^\circ \quad \cos \phi = 0.8 \Rightarrow \phi = 36.87^\circ$$

$$\text{Power} = VI^*$$

$$= \frac{415}{\sqrt{3}} \angle 120^\circ \times 4.15 \angle 6.87^\circ$$

$$= 994.3 \angle 126.87^\circ$$

Reading of wattmeter

$$P = 994.3 (\cos 126.87^\circ)$$

$$= 994.3 (-0.60)$$

$$= -597 \text{ W}$$

Hence (B) is correct option.

**SOL 7.36**

For small values of phase angle

$$\frac{I_P}{I_S} = n\phi, \quad \phi \rightarrow \text{Phase angle (radians)}$$

$$n \rightarrow \text{turns ratio}$$

Magnetizing ampere-turns = 200

So primary current  $I_P = 200 \times 1 = 200 \text{ amp}$

Turns ratio  $n = 500$

**NOTES**

Secondary current  $I_s = 5$  amp

So 
$$\frac{200}{5} = 500\phi$$

$$\phi \text{ (in degrees)} = \left(\frac{180}{\pi}\right)\left(\frac{200}{5 \times 500}\right)$$

$$\simeq 4.58^\circ$$

Hence (A) is correct option.

**SOL 7.37**

Voltage appeared at secondary winding

$$E_s = I_s \times Z_L$$

$$= 5 \times 1$$

$$= 5 \text{ Volts}$$

Voltage induced is given by

$$E_s = \sqrt{2} \pi f N \phi, \quad \phi \rightarrow \text{flux}$$

$$5 = \sqrt{2} \times 3.14 \times 50 \times 500 \times \phi$$

$$\phi = \frac{5}{\sqrt{2} \times 3.14 \times 25 \times 10^3}$$

$$= 45 \times 10^{-6} \text{ wb}$$

Hence (B) is correct option.

**SOL 7.38**

In PMCC instruments, as temperature increases the coil resistance increases. Swamp resistors are connected in series with the moving coil to provide temperature compensation. Swamping resistors is made of magnin, which has a zero-temperature coefficient.

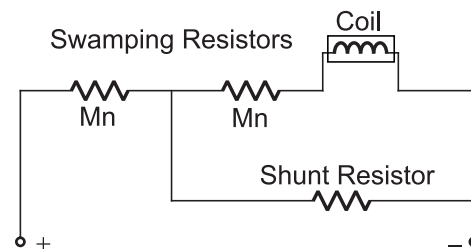

Hence (A) is correct option.

**SOL 7.39**

Effect of stray magnetic field is maximum when the operating field and stray fields are parallel.

**NOTES**

For full wave rectifier

$$(I_{dc})_{fs} = \frac{2I_m}{\pi}, \quad I_m \rightarrow \text{peak value of ac current}$$

$$1 \text{ mA} = \frac{2I_m}{3.14}$$

$$I_m = 1.57 \text{ mA}$$

Full scale ac current

$$(I_{rms})_{fs} = \frac{1.57}{\sqrt{2}} = 1.11 \text{ mA}$$

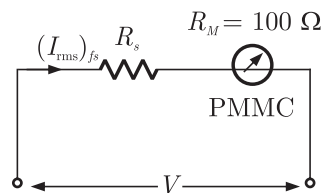

$$V = (R_s + R_m)(I_{rms})_{fs}$$

$$100 = (R_s + 100)(1.11 \text{ mA})$$

$$\frac{100}{(1.11 \text{ mA})} = R_s + 100$$

$$100 \times 900 = R_s + 100$$

$$R_s = 89.9 \text{ k}\Omega$$

Hence (C) is correct option.

**SOL 7.44**

First the current coil is connected in R-phase and pressure coil is connected between this phase and the neutral as shown below

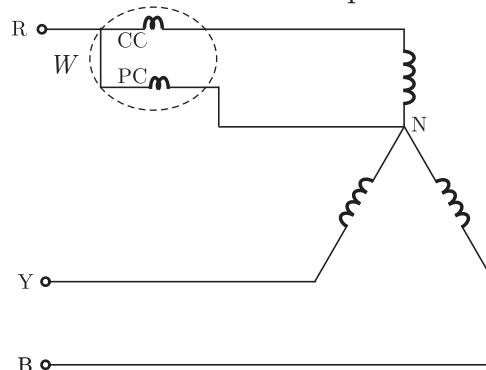

reading of wattmeter

$$W_1 = I_P V_P \cos \theta_1, \quad \cos \theta_1 = 0.8 \Rightarrow \theta_1 = 36.86^\circ$$

$$400 = I_L \frac{V_L}{\sqrt{3}} \cos \theta_1$$

$$400 = \frac{I_L V_L}{\sqrt{3}} \times 0.8 \quad \dots(1)$$

now when pressure coil is connected between B and Y-phases, the circuit is

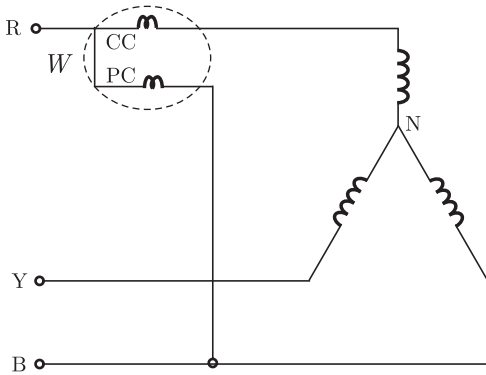

phasor diagram

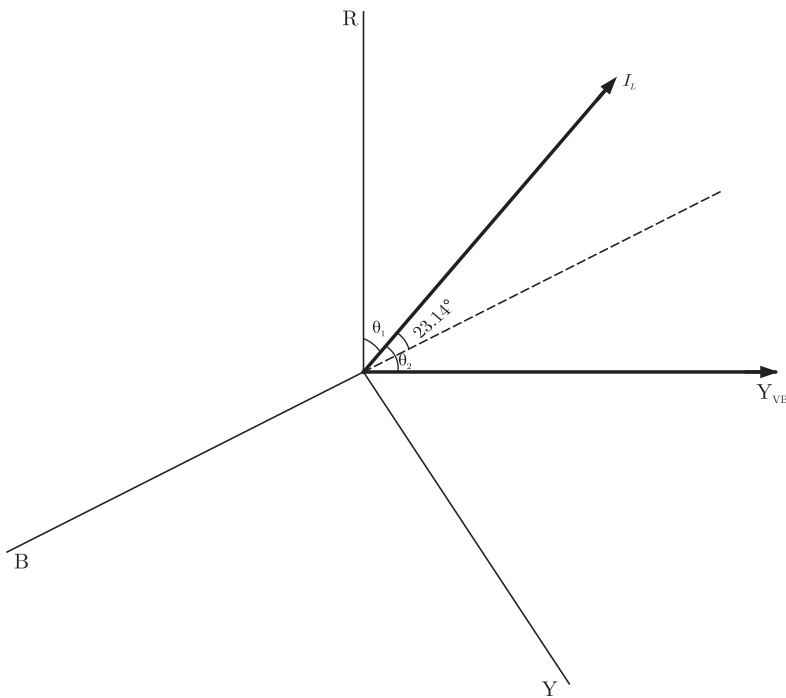

angle  $\theta_2 = 23.14^\circ + 30^\circ = 54.14^\circ$

now wattmeter reading  $W_2 = V_{YB} I_L \cos \theta_2$

from equation (1)  $V_L I_L = \frac{400 \times \sqrt{3}}{0.8}$

so  $W_2 = \frac{400}{0.8} \times \sqrt{3} \times \cos 53.14^\circ$

$$= \frac{100 - 111.80}{111.80} \times 100 = -10.55\%$$

Hence (B) is correct option.

**SOL 7.47**

Power read by meter  $P_m = VI \sin(\Delta - \phi)$

Where

$\Delta$  → Phase angle between supply voltage and pressure coil flux.

$\phi$  → Phase angle of load

Here

$$\Delta = 85^\circ, \phi = 60^\circ \quad \left\{ \because \cos \phi = 0.5 \right.$$

So measured power

$$\begin{aligned} P_m &= 200 \times 5 \sin(85^\circ - 60^\circ) \\ &= 1100 \sin 25^\circ \\ &= 464.88 \text{ W} \end{aligned}$$

Actual power  $P_o = VI \cos \phi$

$$\begin{aligned} &= 220 \times 5 \times 0.5 \\ &= 550 \text{ W} \end{aligned}$$

$$\begin{aligned} \text{Error in measurement} &= P_m - P_o \\ &= 464.88 - 550 \\ &= -85.12 \text{ W} \end{aligned}$$

For unity power factor  $\cos \phi = 1$

$$\phi = 0^\circ$$

$$\begin{aligned} \text{So } P_m &= 220 \times 5 \sin(85^\circ - 0^\circ) \\ &= 1095.81 \text{ W} \end{aligned}$$

$$\begin{aligned} P_o &= 220 \times 5 \cos 0^\circ \\ &= 1100 \end{aligned}$$

$$\begin{aligned} \text{Error in Measurement} &= 1095.81 - 1100 \\ &= -4.19 \text{ W} \end{aligned}$$

Hence (C) is correct option.

**NOTES**

**SOL 7.48**

We can obtain the Lissajou pattern (in X-Y mode) by following method.

For  $\phi = 0^\circ$ ,  $V_x = V_{xm} \sin \omega t$

$$V_y = V_{ym} \sin(\omega t + 0^\circ) = \sin \omega t$$

Draw  $V_x$  and  $V_y$  as shown below

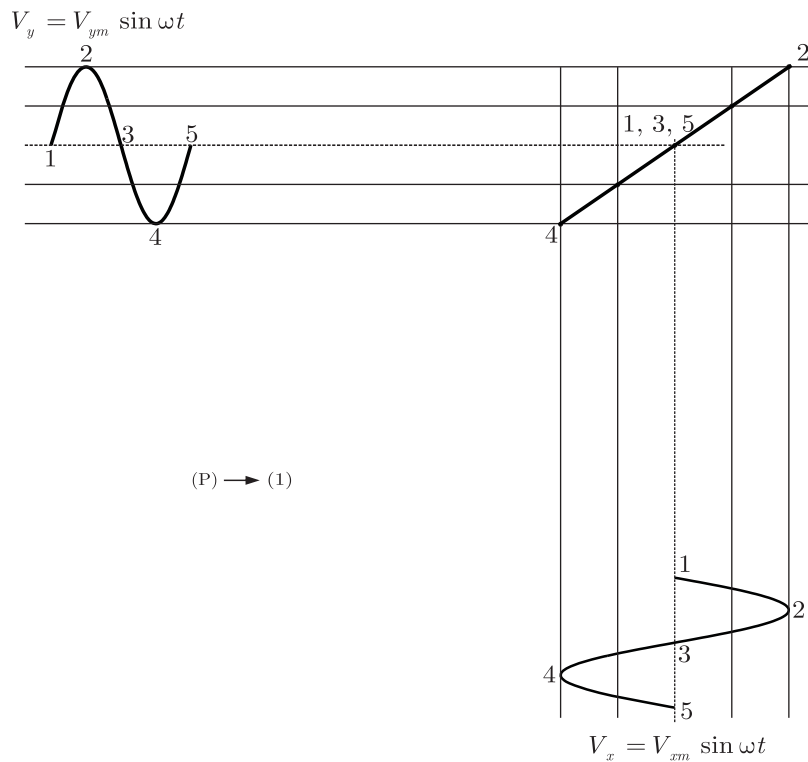

Divide both  $V_y$  and  $V_x$  equal parts and match the corresponding points on the screen.

Similarly for  $\phi = 90^\circ$

$$V_x = V_{xm} \sin \omega t$$

$$V_y = V_{ym} \sin(\omega t + 90^\circ)$$



**NOTES**

**SOL 7.49**

We can obtain the Lissajou pattern (in X-Y mode) by following method.

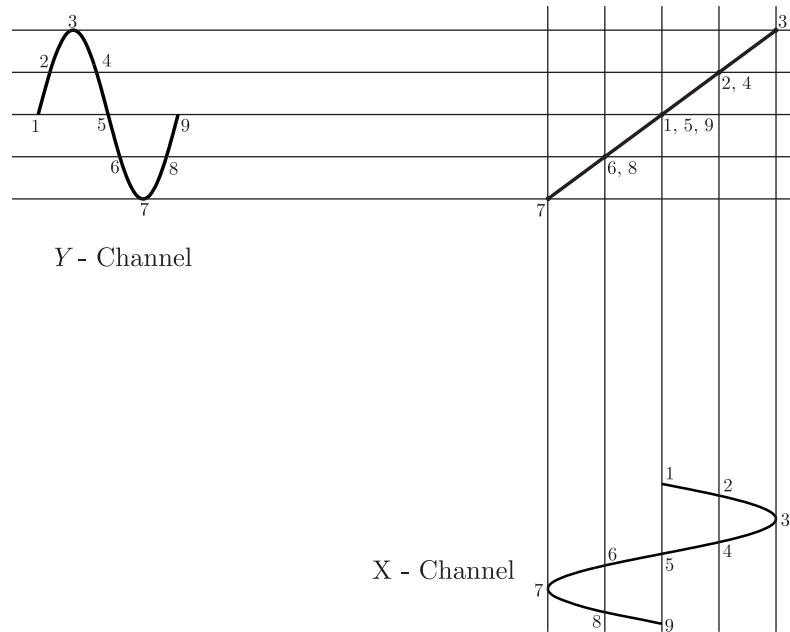

Divide the wave forms appearing on channel X and channel Y in equal parts, match the corresponding points on the screen. We would get a straight line in X – Y mode.

Hence (D) is correct option.

**SOL 7.50**

In two wattmeters method angle between phase voltage and phase current is given by

$$\phi = \tan^{-1} \left( \sqrt{3} \frac{W_2 - W_1}{W_2 + W_1} \right)$$

here  $\phi = -60^\circ$

readings in option (C) only satisfies this equation.

$$\phi = \tan^{-1} \left( \sqrt{3} \frac{0 - 1000}{0 + 1000} \right) = -60^\circ$$

Hence (C) is correct option.

**SOL 7.51**

Speed (rev/sec) of the energy meter is given.

$$S = K \times \text{power}$$

$K \rightarrow$  meter constant

$$S = \frac{10 \text{ rev}}{100 \text{ sec}} = K \times 450$$

$$K = \frac{10 \text{ rev}}{\left(\frac{100 \times 450}{1000 \times 3600}\right) \text{ kWh}}$$

$$= \frac{10 \times 1000 \times 3600}{100 \times 450}$$

$$= 800 \text{ rev/kWh}$$

Hence (D) is correct option.

**SOL 7.52**

Power in a 3-phase three wire system, with balanced load can be measured by using two wattmeters. The load may be star or delta connected.

Hence (B) is correct option.

**SOL 7.53**

A meter configuration is given below

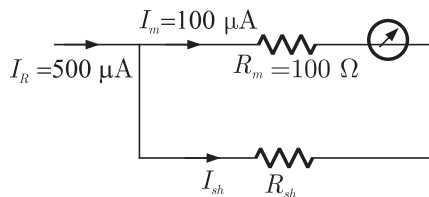

Here

$$I_R = I_m + I_{sh}$$

$$500 = 100 + I_{sh}$$

$$I_{sh} = 400 \mu\text{A}$$

$$\frac{I_m}{I_{sh}} = \frac{R_{sh}}{R_m}$$

$$\frac{100}{400} = \frac{R_{sh}}{100}$$

$$R_{sh} = 25 \Omega$$

Hence (C) is correct option.

**SOL 7.54**

Equivalent resistance when connected in parallel is



**NOTES**

- (A) 4 V  
 (B) 5 V  
 (C) 7.5 V  
 (D) 12.12 V

**YEAR 2010**

**TWO MARKS**

**MCQ 8.3**

The transistor circuit shown uses a silicon transistor with  $V_{BE} = 0.7$ ,  $I_C \approx I_E$  and a dc current gain of 100. The value of  $V_0$  is

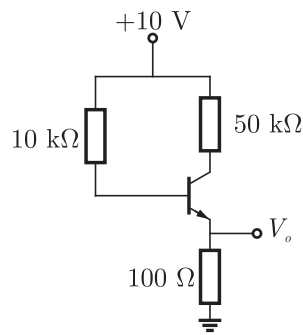

- (A) 4.65 V  
 (B) 5 V  
 (C) 6.3 V  
 (D) 7.23 V

**MCQ 8.4**

The TTL circuit shown in the figure is fed with the waveform  $X$  (also shown). All gates have equal propagation delay of 10 ns. The output  $Y$  of the circuit is

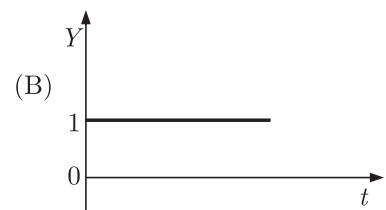
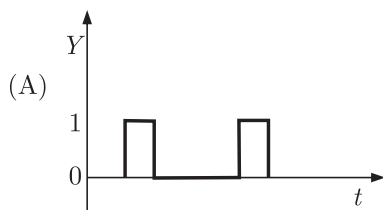
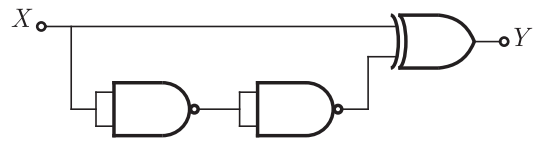
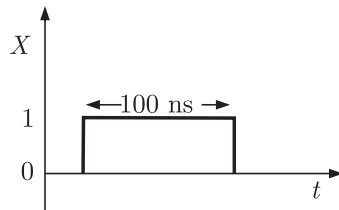

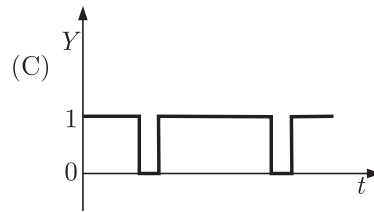
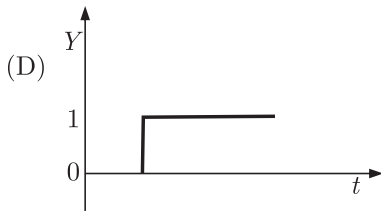

**MCQ 8.5**

When a “CALL Addr” instruction is executed, the CPU carries out the following sequential operations internally :

Note: (R) means content of register R

((R)) means content of memory location pointed to by R.

PC means Program Counter

SP means Stack Pointer

- |                      |                   |
|----------------------|-------------------|
| (A) (SP) incremented | (B) (PC) ← Addr   |
| (PC) ← Addr          | ((SP)) ← (PC)     |
| ((SP)) ← (PC)        | (SP) incremented  |
| (C) (PC) ← Addr      | (D) ((SP)) ← (PC) |
| (SP) incremented     | (SP) incremented  |
| ((SP)) ← (PC)        | (PC) ← Addr       |

**Statement For Linked Answer Questions: 6 & 7**

The following Karnaugh map represents a function  $F$ .

$F$		$YZ$			
		00	01	11	10
$X$	0	1	1	1	0
	1	0	0	1	0

**MCQ 8.6**

A minimized form of the function  $F$  is

- |                                       |                                       |
|---------------------------------------|---------------------------------------|
| (A) $F = \bar{X} Y + YZ$              | (B) $F = \bar{X} \bar{Y} + YZ$        |
| (C) $F = \bar{X} \bar{Y} + Y \bar{Z}$ | (D) $F = \bar{X} \bar{Y} + \bar{Y} Z$ |

**NOTES**

**MCQ 8.7**

Which of the following circuits is a realization of the above function  $F$  ?

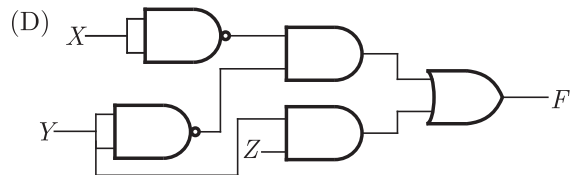
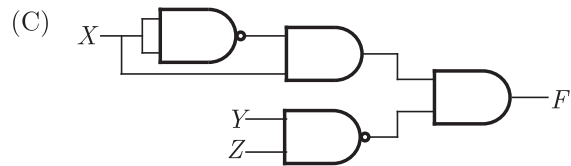
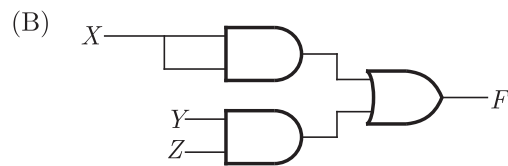
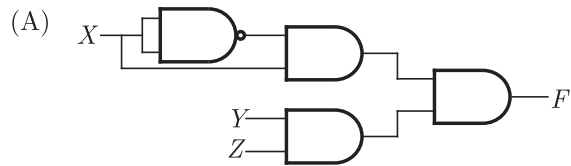

**YEAR 2009**

**ONE MARK**

**MCQ 8.8**

The following circuit has a source voltage  $V_s$  as shown in the graph. The current through the circuit is also shown.

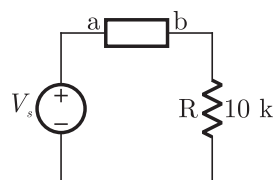

**NOTES**

- (A) Current-Current feedback
- (B) Voltage-Voltage feedback
- (C) Current-Voltage feedback
- (D) Voltage-Current feedback

**MCQ 8.11**

The complete set of only those Logic Gates designated as Universal Gates is

- (A) NOT, OR and AND Gates
- (B) XNOR, NOR and NAND Gates
- (C) NOR and NAND Gates
- (D) XOR, NOR and NAND Gates

**YEAR 2009**

**TWO MARKS**

**MCQ 8.12**

The following circuit has  $R = 10\text{ k}\Omega$ ,  $C = 10\text{ }\mu\text{F}$ . The input voltage is a sinusoidal at 50 Hz with an rms value of 10 V. Under ideal conditions, the current  $I_s$  from the source is

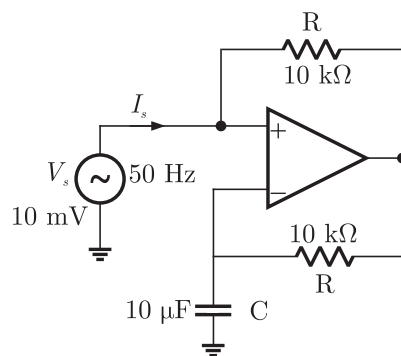

- (A)  $10\pi$  mA leading by  $90^\circ$
- (B)  $20\pi$  mA leading by  $90^\circ$
- (C)  $10\pi$  mA leading by  $90^\circ$
- (D)  $10\pi$  mA lagging by  $90^\circ$

**MCQ 8.13**

Transformer and emitter follower can both be used for impedance matching at the output of an audio amplifier. The basic relationship between the input power  $P_{in}$  and output power  $P_{out}$  in both the cases is

- (A)  $P_{in} = P_{out}$  for both transformer and emitter follower
- (B)  $P_{in} > P_{out}$  for both transformer and emitter follower
- (C)  $P_{in} < P_{out}$  for transformer and  $P_{in} = P_{out}$  for emitter follower
- (D)  $P_{in} = P_{out}$  for transformer and  $P_{in} < P_{out}$  for emitter follower

**MCQ 8.14**

In an 8085 microprocessor, the contents of the Accumulator, after the following instructions are executed will become

```
XRA  A
MVI  B, F0 H
SUB  B
```

- (A) 01 H
- (B) 0F H
- (C) F0 H
- (D) 10 H

**MCQ 8.15**

An ideal op-amp circuit and its input wave form as shown in the figures. The output waveform of this circuit will be

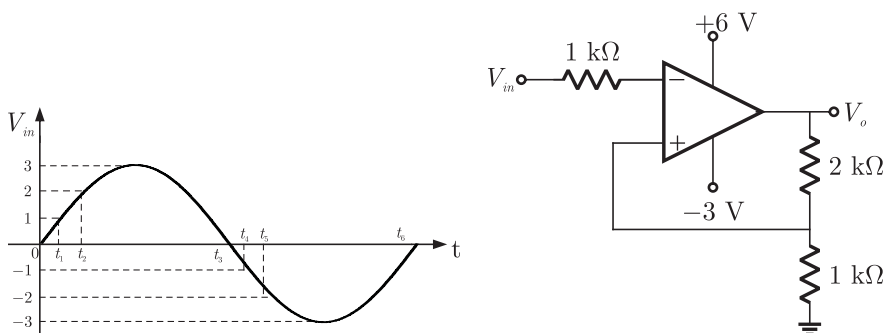





**NOTES**

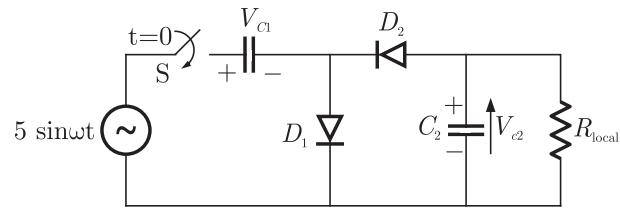

- (A)  $V_{c1} = 10 \text{ V}, V_{c2} = 5 \text{ V}$                       (B)  $V_{c1} = 10 \text{ V}, V_{c2} = -5 \text{ V}$   
 (C)  $V_{c1} = 5 \text{ V}, V_{c2} = 10 \text{ V}$                       (D)  $V_{c1} = 5 \text{ V}, V_{c2} = -10 \text{ V}$

**MCQ 8.19**

The block diagrams of two of half wave rectifiers are shown in the figure. The transfer characteristics of the rectifiers are also shown within the block.

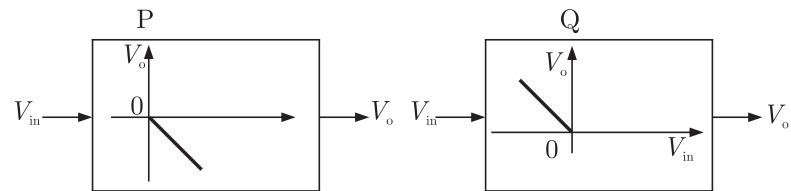

It is desired to make full wave rectifier using above two half-wave rectifiers. The resultant circuit will be

- (A)

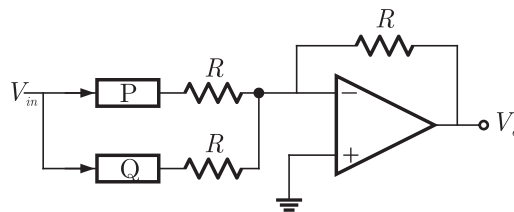

- (B)

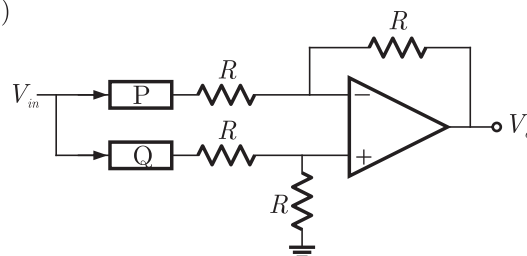

**NOTES**

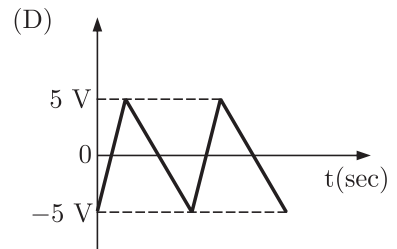
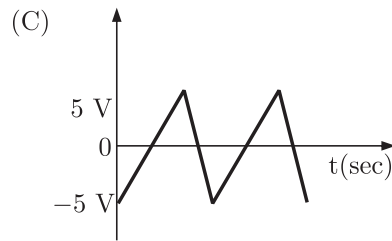

**Statement for Linked Answer Questions 21 and 22.**

A general filter circuit is shown in the figure :

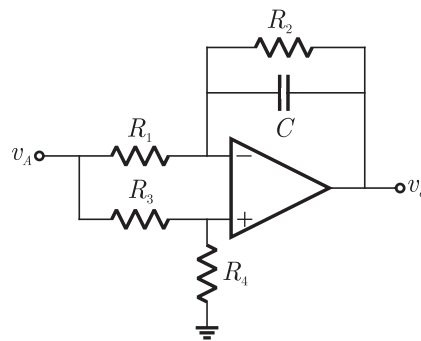

**MCQ 8.21**

If  $R_1 = R_2 = R_A$  and  $R_3 = R_4 = R_B$ , the circuit acts as a

- (A) all pass filter
- (B) band pass filter
- (C) high pass filter
- (D) low pass filter

**MCQ 8.22**

The output of the filter in Q.21 is given to the circuit in figure :

The gain v/s frequency characteristic of the output ( $v_o$ ) will be

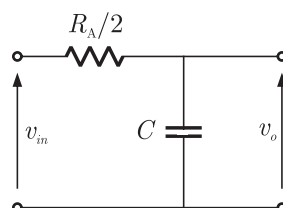

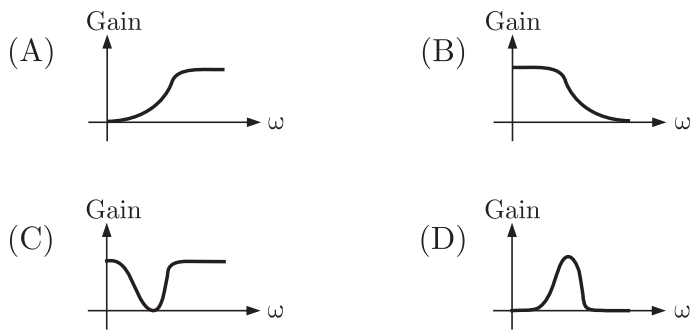

**MCQ 8.23**

A 3-line to 8-line decoder, with active low outputs, is used to implement a 3-variable Boolean function as shown in the figure

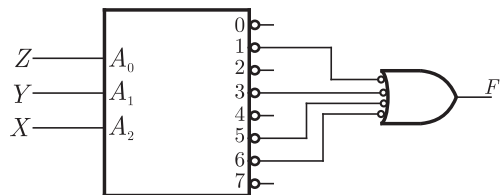

The simplified form of Boolean function  $F(A, B, C)$  implemented in 'Product of Sum' form will be

- (A)  $(X + Z)(\bar{X} + \bar{Y} + \bar{Z})(Y + Z)$
- (B)  $(\bar{X} + \bar{Z})(X + Y + Z)(\bar{Y} + \bar{Z})$
- (C)  $(\bar{X} + \bar{Y} + Z)(\bar{X} + Y + Z)(X + \bar{Y} + Z)(X + Y + \bar{Z})$
- (D)  $(\bar{X} + \bar{Y} + Z)(\bar{X} + Y + \bar{Z})(X + \bar{Y} + Z)(X + \bar{Y} + \bar{Z})$

**MCQ 8.24**

The content of some of the memory location in an 8085 accumulator based system are given below

Address	Content
...	...
26FE	00
26FF	01
2700	02
2701	03
2702	04
...	...



**NOTES**

- (A)  $S$  is always with zero or odd
- (B)  $S$  is always either zero or even
- (C)  $S = 1$  only if the sum of  $A, B, C$  and  $D$  is even
- (D)  $S = 1$  only if the sum of  $A, B, C$  and  $D$  is odd

**YEAR 2007**

**TWO MARKS**

**MCQ 8.29**

The input signal  $V_{in}$  shown in the figure is a 1 kHz square wave voltage that alternates between +7 V and -7 V with a 50% duty cycle. Both transistor have the same current gain which is large. The circuit delivers power to the load resistor  $R_L$ . What is the efficiency of this circuit for the given input ? choose the closest answer.

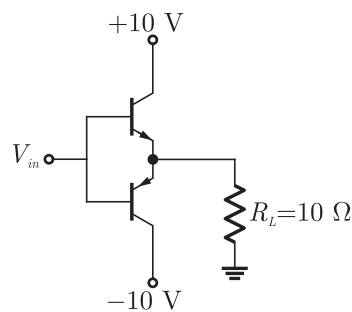

- (A) 46%
- (B) 55%
- (C) 63%
- (D) 92%

**MCQ 8.30**

The switch  $S$  in the circuit of the figure is initially closed, it is opened at time  $t = 0$ . You may neglect the zener diode forward voltage drops. What is the behavior of  $v_{out}$  for  $t > 0$  ?

**NOTES**

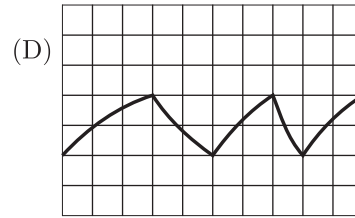
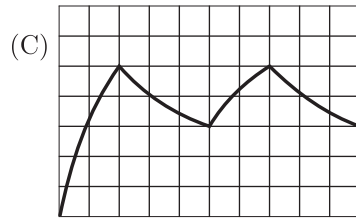
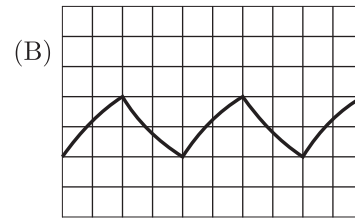
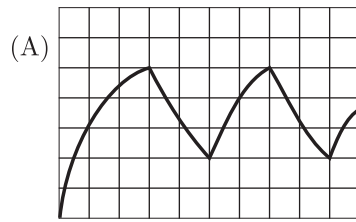

**YEAR 2006**

**ONE MARK**

**MCQ 8.33**

What are the states of the three ideal diodes of the circuit shown in figure ?

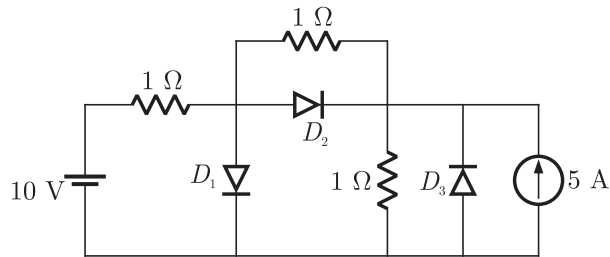

- (A)  $D_1$  ON,  $D_2$  OFF,  $D_3$  OFF
- (B)  $D_1$  OFF,  $D_2$  ON,  $D_3$  OFF
- (C)  $D_1$  ON,  $D_2$  OFF,  $D_3$  ON
- (D)  $D_1$  OFF,  $D_2$  ON,  $D_3$  ON

**MCQ 8.34**

For a given sinusoidal input voltage, the voltage waveform at point P of the clamper circuit shown in figure will be

**NOTES**

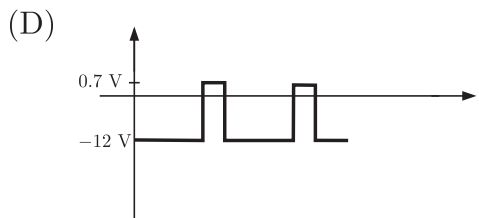
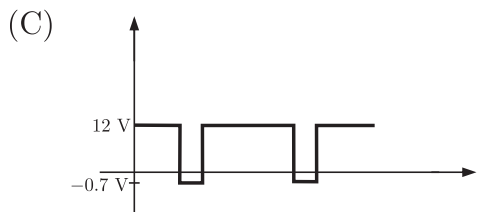
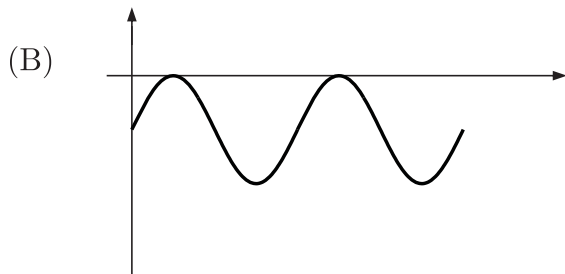
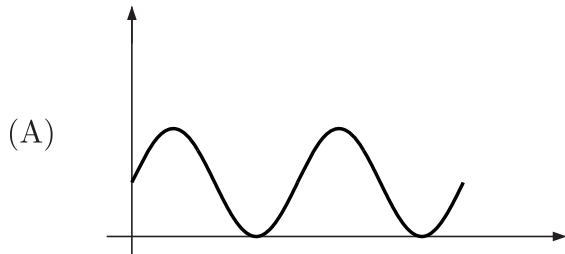
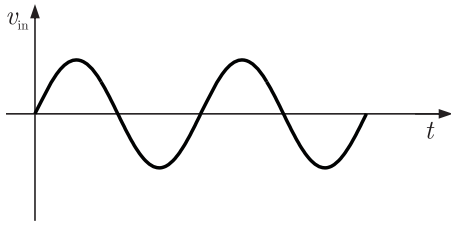
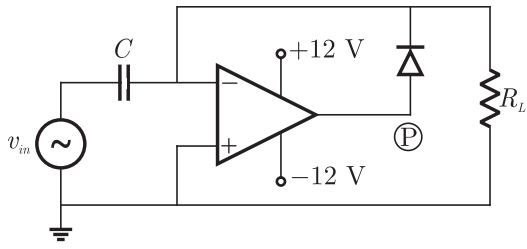



- (A) saturation region                      (B) active region  
 (C) breakdown region                    (D) cut-off region

**MCQ 8.37**

A relaxation oscillator is made using OPAMP as shown in figure. The supply voltages of the OPAMP are  $\pm 12\text{ V}$ . The voltage waveform at point P will be

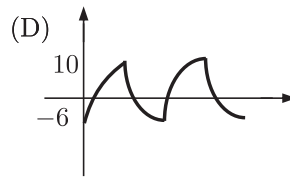
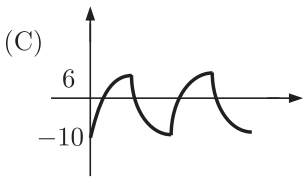
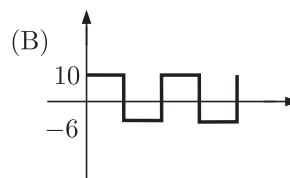
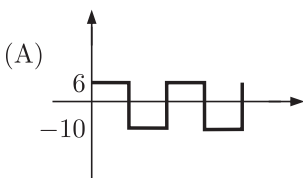
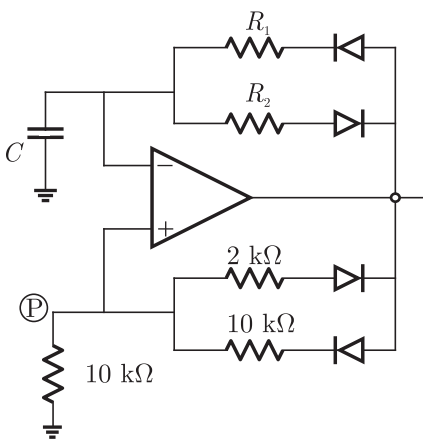

**MCQ 8.38**

A TTL NOT gate circuit is shown in figure. Assuming  $V_{BE} = 0.7\text{ V}$  of both the transistors, if  $V_i = 3.0\text{ V}$ , then the states of the two transistors will be

**NOTES**

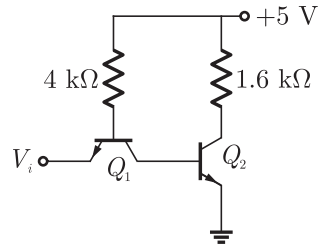

- (A)  $Q_1$  ON and  $Q_2$  OFF
- (B)  $Q_1$  reverse ON and  $Q_2$  OFF
- (C)  $Q_1$  reverse ON and  $Q_2$  ON
- (D)  $Q_1$  OFF and  $Q_2$  reverse ON

**MCQ 8.39**

A student has made a 3-bit binary down counter and connected to the  $R$ - $2R$  ladder type DAC, [Gain =  $(-1\text{ k}\Omega/2R)$ ] as shown in figure to generate a staircase waveform. The output achieved is different as shown in figure. What could be the possible cause of this error ?

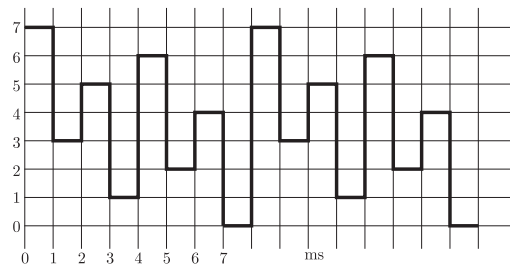
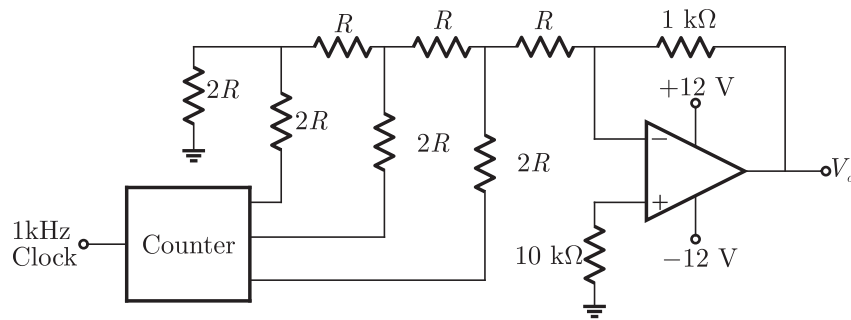

- (A) The resistance values are incorrect option.
- (B) The counter is not working properly
- (C) The connection from the counter of DAC is not proper
- (D) The  $R$  and  $2R$  resistance are interchanged

**MCQ 8.43**

Assume that  $D_1$  and  $D_2$  in figure are ideal diodes. The value of current is

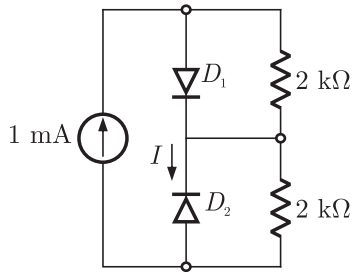

- (A) 0 mA
- (B) 0.5 mA
- (C) 1 mA
- (D) 2 mA

**MCQ 8.44**

The 8085 assembly language instruction that stores the content of H and L register into the memory locations  $2050_H$  and  $2051_H$ , respectively is

- (A) SPHL  $2050_H$
- (B) SPHL  $2051_H$
- (C) SHLD  $2050_H$
- (D) STAX  $2050_H$

**MCQ 8.45**

Assume that the N-channel MOSFET shown in the figure is ideal, and that its threshold voltage is  $+1.0\text{ V}$  the voltage  $V_{ab}$  between nodes  $a$  and  $b$  is

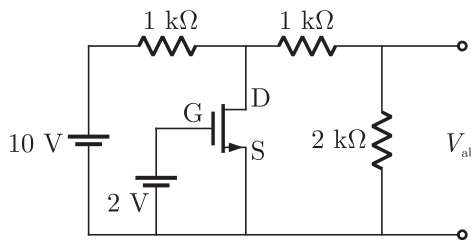

- (A) 5 V
- (B) 2 V
- (C) 1 V
- (D) 0 V

**MCQ 8.46**

The digital circuit shown in the figure works as

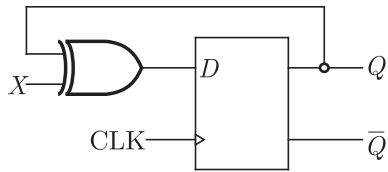

- (A) JK flip-flop  
 (B) Clocked RS flip-flop  
 (C) T flip-flop  
 (D) Ring counter

**YEAR 2005**

**TWO MARKS**

**MCQ 8.47**

The common emitter amplifier shown in the figure is biased using a 1 mA ideal current source. The approximate base current value is

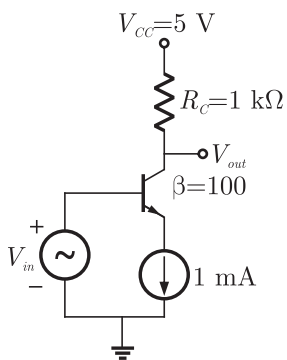

- (A)  $0 \mu A$   
 (B)  $10 \mu A$   
 (C)  $100 \mu A$   
 (D)  $1000 \mu A$

**MCQ 8.48**

Consider the inverting amplifier, using an ideal operational amplifier shown in the figure. The designer wishes to realize the input resistance seen by the small-signal source to be as large as possible, while keeping the voltage gain between  $-10$  and  $-25$ . The upper limit on  $R_F$  is  $1 \text{ M}\Omega$ . The value of  $R_1$  should be

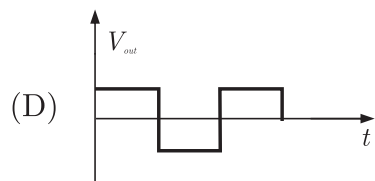
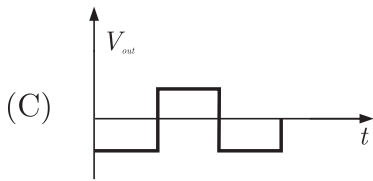
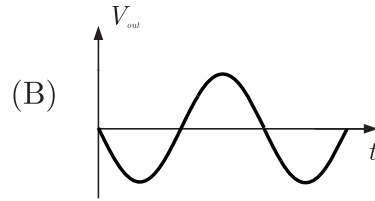
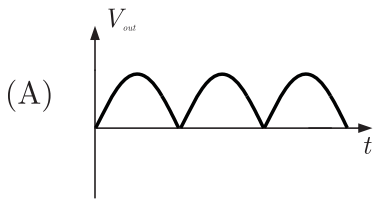

**MCQ 8.51**

Select the circuit which will produce the given output  $Q$  for the input signals  $X_1$  and  $X_2$  given in the figure

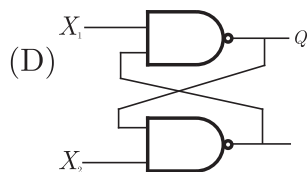
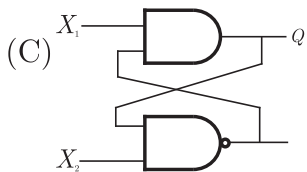
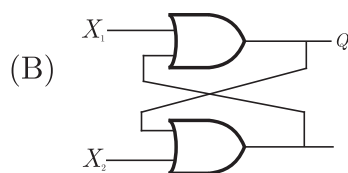
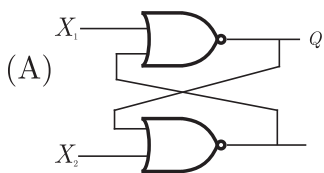
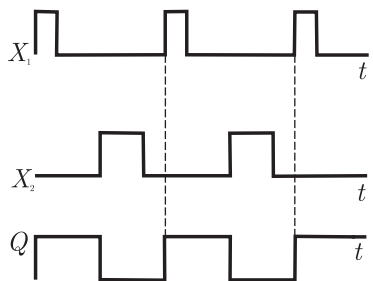

**MCQ 8.52**

If  $X_1$  and  $X_2$  are the inputs to the circuit shown in the figure, the output  $Q$  is



**NOTES**

- (A) 0 mA  
 (B) 2.3 mA  
 (C) 4.3 mA  
 (D) 7.3 mA

**MCQ 8.58**

The feedback used in the circuit shown in figure can be classified as

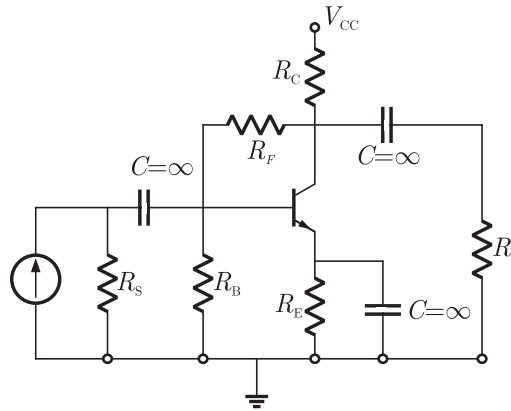

- (A) shunt-series feedback  
 (B) shunt-shunt feedback  
 (C) series-shunt feedback  
 (D) series-series feedback

**MCQ 8.59**

The digital circuit using two inverters shown in figure will act as

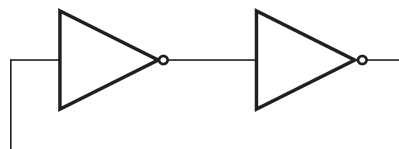

- (A) a bistable multi-vibrator  
 (B) an astable multi-vibrator  
 (C) a monostable multi-vibrator  
 (D) an oscillator

**MCQ 8.60**

The voltage comparator shown in figure can be used in the analog-to-digital conversion as

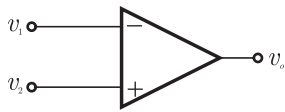

- (A) a 1-bit quantizer  
 (B) a 2-bit quantizer  
 (C) a 4-bit quantizer  
 (D) a 8-bit quantizer

**YEAR 2004**

**TWO MARKS**

**MCQ 8.61**

Assuming that the diodes are ideal in figure, the current in diode  $D_1$  is

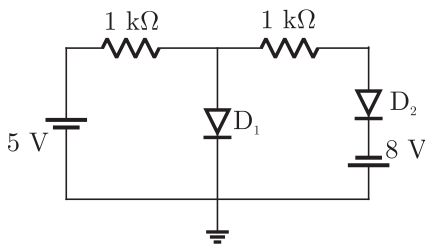

- (A) 9 mA  
 (B) 5 mA  
 (C) 0 mA  
 (D) -3 mA

**MCQ 8.62**

The trans-conductance  $g_m$  of the transistor shown in figure is 10 mS. The value of the input resistance  $R_{in}$  is

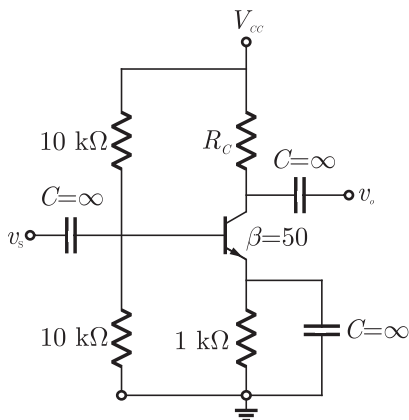

- (A) 10.0 kΩ  
 (B) 8.3 kΩ  
 (C) 5.0 kΩ  
 (D) 2.5 kΩ



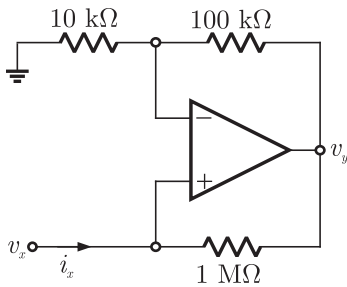

- (A) +100 kΩ                      (B) -100 kΩ  
 (C) +1 MΩ                        (D) -1 MΩ

**MCQ 8.66**

The simplified form of the Boolean expression  $Y = (\bar{A} \cdot BC + D)(\bar{A} \cdot D + \bar{B} \cdot \bar{C})$  can be written as

- (A)  $\bar{A} \cdot D + \bar{B} \cdot \bar{C} \cdot D$   
 (B)  $AD + B \cdot \bar{C} \cdot D$   
 (C)  $(\bar{A} + D)(\bar{B} \cdot C + \bar{D})$   
 (D)  $A \cdot \bar{D} + BC \cdot \bar{D}$

**MCQ 8.67**

A digit circuit which compares two numbers  $A_3A_2A_1A_0$  and  $B_3B_2B_1B_0$  is shown in figure. To get output  $Y = 0$ , choose one pair of correct input numbers.

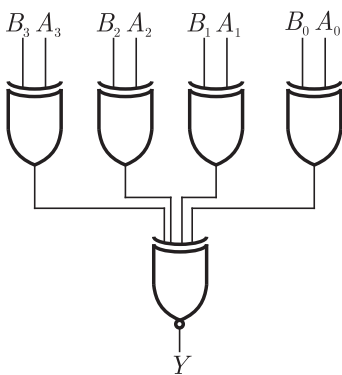

- (A) 1010, 1010                      (B) 0101, 0101  
 (C) 0010, 0010                      (D) 1010, 1011

**NOTES**

**MCQ 8.68**

The digital circuit shown in figure generates a modified clock pulse at the output. Choose the correct output waveform from the options given below.

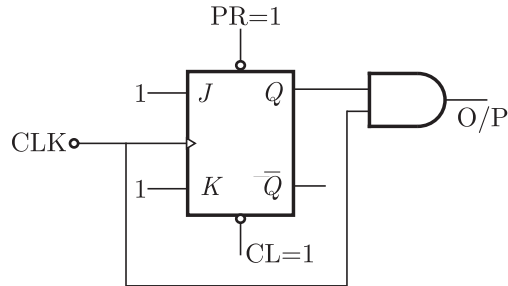

**MCQ 8.69**

If the following program is executed in a microprocessor, the number of instruction cycle it will take from START to HALT is

```
START      MVI A, 14H ;      Move 14 H to register A
SHIFT     RLC          ;      Rotate left without carry
          JNZ SHIFT ;      Jump on non-zero to SHIFT
          HALT
```

**NOTES**

**MCQ 8.72**

In the circuit of figure, assume that the transistor has  $h_{fe} = 99$  and  $V_{BE} = 0.7$  V. The value of collector current  $I_C$  of the transistor is approximately

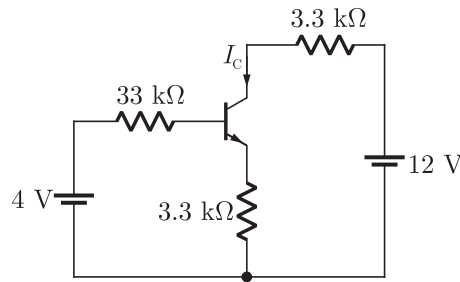

- (A)  $[3.3/3.3]$  mA                      (B)  $[3.3/(3.3+3.3)]$  mA  
 (C)  $[3.3/.33]$  mA                      (D)  $[3.3(33+3.3)]$  mA

**MCQ 8.73**

For the circuit of figure with an ideal operational amplifier, the maximum phase shift of the output  $v_{out}$  with reference to the input  $v_{in}$  is

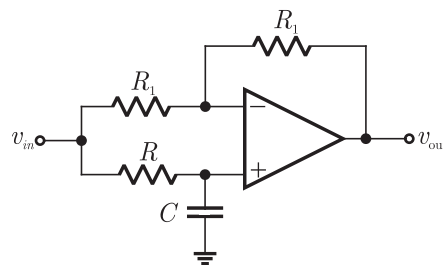

- (A)  $0^\circ$                                       (B)  $-90^\circ$   
 (C)  $+90^\circ$                                   (D)  $\pm 180^\circ$

**MCQ 8.74**

Figure shows a 4 to 1 MUX to be used to implement the sum  $S$  of a 1-bit full adder with input bits  $P$  and  $Q$  and the carry input  $C_{in}$ . Which of the following combinations of inputs to  $I_0, I_1, I_2$  and  $I_3$  of the MUX will realize the sum  $S$  ?

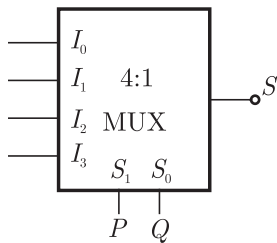

- (A)  $I_0 = I_1 = C_{in}; I_2 = I_3 = \overline{C_{in}}$
- (B)  $I_0 = I_1 = \overline{C_{in}}; I_2 = I_3 = C_{in}$
- (C)  $I_0 = I_3 = C_{in}; I_1 = I_2 = \overline{C_{in}}$
- (D)  $I_0 = I_3 = \overline{C_{in}}; I_1 = I_2 = C_{in}$

**MCQ 8.75**

When a program is being executed in an 8085 microprocessor, its Program Counter contains

- (A) the number of instructions in the current program that have already been executed
- (B) the total number of instructions in the program being executed.
- (C) the memory address of the instruction that is being currently executed
- (D) the memory address of the instruction that is to be executed next

**YEAR 2003**

**TWO MARKS**

**MCQ 8.76**

For the n-channel enhancement MOSFET shown in figure, the threshold voltage  $V_{th} = 2$  V. The drain current  $I_D$  of the MOSFET is 4 mA when the drain resistance  $R_D$  is 1 k $\Omega$ . If the value of  $R_D$  is increased to 4 k $\Omega$ , drain current  $I_D$  will become

**MCQ 8.79**

The circuit of figure shows a 555 Timer IC connected as an astable multi-vibrator. The value of the capacitor  $C$  is 10 nF. The values of the resistors  $R_A$  and  $R_B$  for a frequency of 10 kHz and a duty cycle of 0.75 for the output voltage waveform are

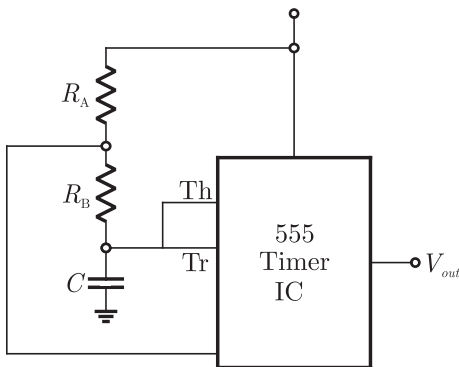

- (A)  $R_A = 3.62 \text{ k}\Omega, R_B = 3.62 \text{ k}\Omega$
- (B)  $R_A = 3.62 \text{ k}\Omega, R_B = 7.25 \text{ k}\Omega$
- (C)  $R_A = 7.25 \text{ k}\Omega, R_B = 3.62 \text{ k}\Omega$
- (D)  $R_A = 7.25 \text{ k}\Omega, R_B = 7.25 \text{ k}\Omega$

**MCQ 8.80**

The boolean expression  $\bar{X} Y \bar{Z} + \bar{X} \bar{Y} Z + X Y \bar{Z} + X \bar{Y} Z + X Y Z$  can be simplified to

- (A)  $X\bar{Z} + \bar{X}Z + YZ$
- (B)  $XY + \bar{Y}Z + Y\bar{Z}$
- (C)  $\bar{X}Y + YZ + XZ$
- (D)  $\bar{X}\bar{Y} + Y\bar{Z} + \bar{X}Z$

**MCQ 8.81**

The shift register shown in figure is initially loaded with the bit pattern 1010. Subsequently the shift register is clocked, and with each clock pulse the pattern gets shifted by one bit position to the right. With each shift, the bit at the serial input is pushed to the left most position (msb). After how many clock pulses will the content of the shift register become 1010 again ?

**NOTES**

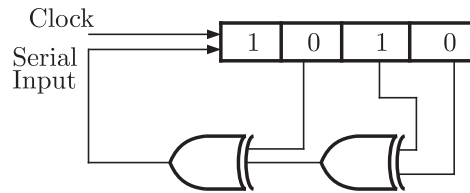

- (A) 3  
 (B) 7  
 (C) 11  
 (D) 15

**MCQ 8.82**

An X-Y flip-flop, whose Characteristic Table is given below is to be implemented using a J-K flip flop

X	Y	$Q_{n+1}$
0	0	1
0	1	$Q_n$
1	0	$\bar{Q}_n$
1	1	0

- (A)  $J = X, K = \bar{Y}$   
 (B)  $J = \bar{X}, K = Y$   
 (C)  $J = Y, K = \bar{X}$   
 (D)  $J = \bar{Y}, K = X$

**MCQ 8.83**

A memory system has a total of 8 memory chips each with 12 address lines and 4 data lines, The total size of the memory system is

- (A) 16 kbytes  
 (B) 32 kbytes  
 (C) 48 kbytes  
 (D) 64 kbytes

**MCQ 8.84**

The following program is written for an 8085 microprocessor to add two bytes located at memory addresses 1FFE and 1FFF

```
LXI H, 1FFE
MOV B, M
INR L
MOV A, M
ADD B
```

**NOTES**

(C)  $\frac{V_m}{100\pi\sqrt{2}}$

(D)  $\frac{2V_m}{50\pi}$

**MCQ 8.87**

The cut-in voltage of both zener diode  $D_Z$  and diode  $D$  shown in Figure is 0.7 V, while break-down voltage of  $D_Z$  is 3.3 V and reverse break-down voltage of  $D$  is 50 V. The other parameters can be assumed to be the same as those of an ideal diode. The values of the peak output voltage ( $V_o$ ) are

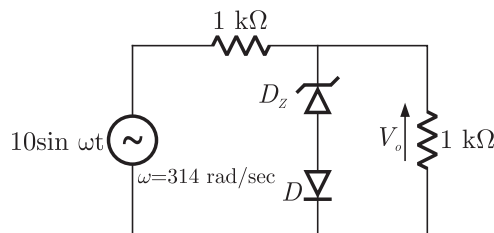

- (A) 3.3 V in the positive half cycle and 1.4 V in the negative half cycle.
- (B) 4 V in the positive half cycle and 5 V in the negative half cycle.
- (C) 3.3 V in both positive and negative half cycles.
- (D) 4 V in both positive and negative half cycle

**MCQ 8.88**

The logic circuit used to generate the active low chip select ( $\overline{CS}$ ) by an 8085 microprocessor to address a peripheral is shown in Figure. The peripheral will respond to addresses in the range.

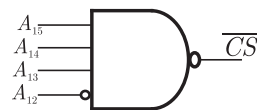

- (A) E000-EFFF
- (B) 000E-FFFE
- (C) 1000-FFFF
- (D) 0001-FFF1

**YEAR 2002**

**TWO MARKS**

**MCQ 8.89**

A first order, low pass filter is given with  $R = 50 \Omega$  and  $C = 5 \mu\text{F}$

. What is the frequency at which the gain of the voltage transfer function of the filter is 0.25 ?

- (A) 4.92 kHz (B) 0.49 kHz  
 (C) 2.46 kHz (D) 24.6 kHz

**MCQ 8.90**

The output voltage ( $v_o$ ) of the Schmitt trigger shown in Figure swings between +15 V and -15 V. Assume that the operational amplifier is ideal. The output will change from +15 V to -15 V when the instantaneous value of the input sine wave is

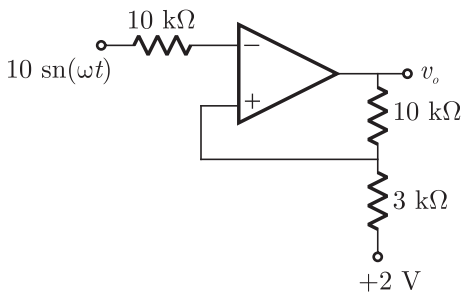

- (A) 5 V in the positive slope only  
 (B) 5 V in the negative slope only  
 (C) 5 V in the positive and negative slopes  
 (D) 3 V in the positive and negative slopes.

**MCQ 8.91**

For the circuit shown in Figure, the boolean expression for the output  $Y$  in terms of inputs  $P, Q, R$  and  $S$  is

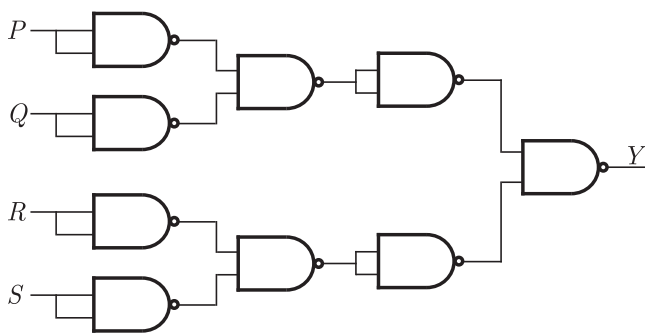

- (A)  $\bar{P} + \bar{Q} + \bar{R} + \bar{S}$  (B)  $P + Q + R + S$   
 (C)  $(\bar{P} + \bar{Q})(\bar{R} + \bar{S})$  (D)  $(P + Q)(R + S)$



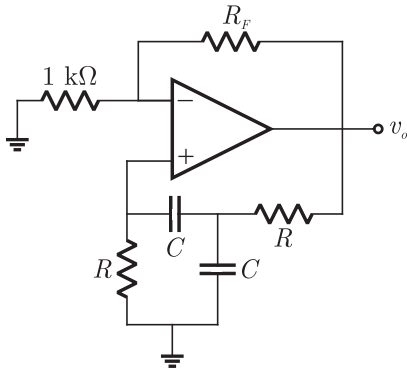
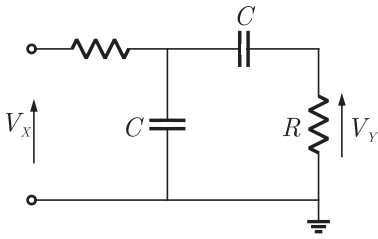

**MCQ 8.95**

The transfer function  $\frac{V_y}{V_x}$  of the first network is

- (A)  $\frac{j\omega CR}{(1 - \omega^2 R^2 C^2) + j3\omega CR}$       (B)  $\frac{j\omega CR}{(1 - \omega^2 R^2 C^2) + j2\omega CR}$   
 (C)  $\frac{j\omega CR}{1 + j3\omega CR}$       (D)  $\frac{j\omega CR}{1 + j2\omega CR}$

**MCQ 8.96**

The frequency of oscillation will be

- (A)  $\frac{1}{RC}$       (B)  $\frac{1}{2RC}$   
 (C)  $\frac{1}{4RC}$       (D) None of these

**MCQ 8.97**

Value of  $R_F$  is

- (A) 1 kΩ      (B) 4 kΩ  
 (C) 2 kΩ      (D) 8 kΩ

**NOTES**

**MCQ 8.98\***

The ripple counter shown in figure is made up of negative edge triggered J-K flip-flops. The signal levels at  $J$  and  $K$  inputs of all the flip flops are maintained at logic 1. Assume all the outputs are cleared just prior to applying the clock signal.

module no. of the counter is:

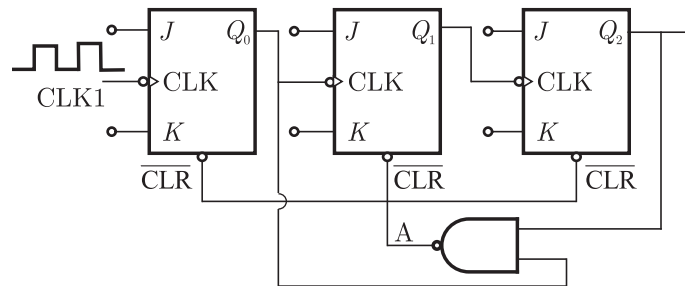

- (A) 7 (B) 5  
 (C) 4 (D) 8

**MCQ 8.99\***

In Figure , the ideal switch  $S$  is switched on and off with a switching frequency  $f = 10$  kHz. The switching time period is  $T = t_{ON} + t_{OFF}$   $\mu$ s. The circuit is operated in steady state at the boundary of continuous and discontinuous conduction, so that the inductor current  $i$  is as shown in Figure. Values of the on-time  $t_{ON}$  of the switch and peak current  $i_p$ . are

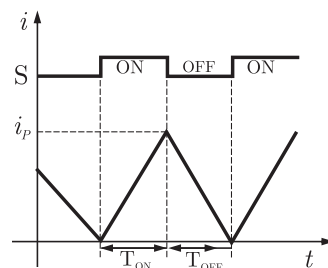
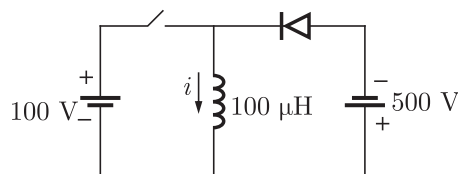

**MCQ 8.102**

In the single-stage transistor amplifier circuit shown in Figure, the capacitor  $C_E$  is removed. Then, the ac small-signal mid-band voltage gain of the amplifier

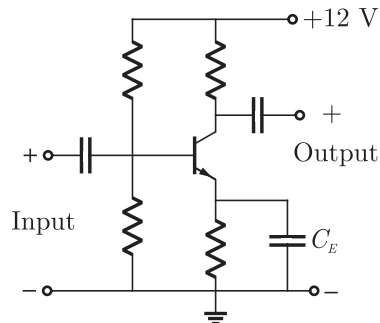

- (A) increase  
 (B) decreases  
 (C) is unaffected  
 (D) drops to zero

**MCQ 8.103**

Among the following four, the slowest ADC (analog-to-digital converter) is

- (A) parallel-comparator (i.e. flash) type  
 (B) successive approximation type  
 (C) integrating type  
 (D) counting type

**MCQ 8.104**

The output of a logic gate is “1” when all its inputs are at logic “0”. The gate is either

- (A) a NAND or an EX-OR gate  
 (B) a NOR or an EX-OR gate  
 (C) an AND or an EX-NOR gate  
 (D) a NOR or an EX-NOR gate

**MCQ 8.105**

The output  $f$  of the 4-to-1 MUX shown in Figure is

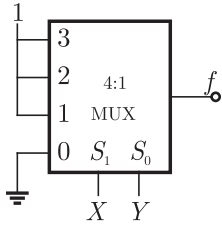

- (A)  $\overline{xy} + x$                       (B)  $x + y$   
 (C)  $\overline{x} + \overline{y}$                       (D)  $xy + \overline{x}$

**MCQ 8.106**

An op-amp has an open-loop gain of  $10^5$  and an open-loop upper cut-off frequency of 10 Hz. If this op-amp is connected as an amplifier with a closed-loop gain of 100, then the new upper cut-off frequency is

- (A) 10 Hz                                  (B) 100 Hz  
 (C) 10 kHz                                (D) 100 kHz

**YEAR 2001**

**TWO MARKS**

**MCQ 8.107**

For the oscillator circuit shown in Figure, the expression for the time period of oscillation can be given by (where  $\tau = RC$ )

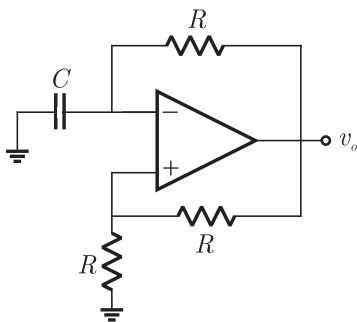

- (A)  $\tau \ln 3$                                 (B)  $2\tau \ln 3$   
 (C)  $\tau \ln 2$                                 (D)  $2\tau \ln 2$

- (A) 1.5 (B) 2.0  
 (C) 2.5 (D) 3.0

**MCQ 8.112\***

The circuit shown in the figure is a MOD- $N$  ring counter. Value of  $N$  is (assume initial state of the counter is 1110 i.e.  $Q_3 Q_2 Q_1 Q_0 = 1110$ ).

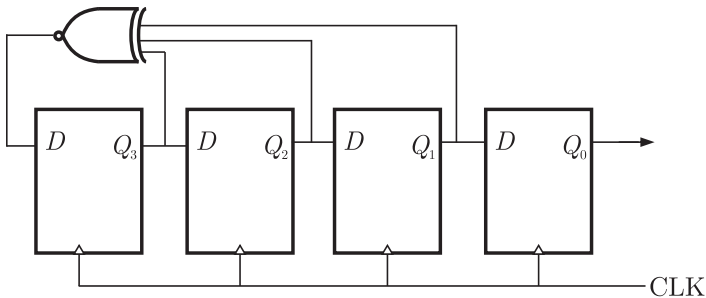

- (A) 4 (B) 15  
 (C) 7 (D) 6

**MCQ 8.113\***

For the op-amp circuit shown in Figure, determine the output voltage  $v_o$ . Assume that the op-amps are ideal.

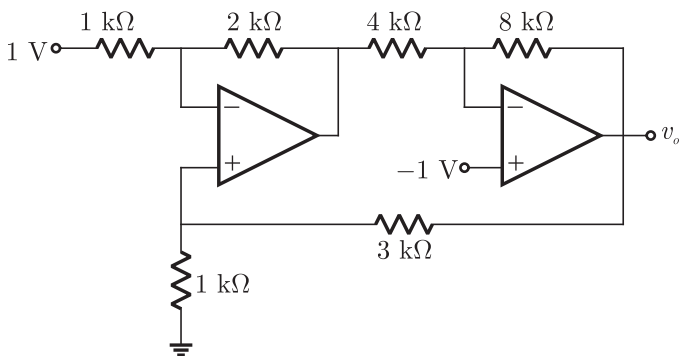

- (A)  $-\frac{8}{7}$  V (B)  $-\frac{20}{7}$  V  
 (C)  $-10$  V (D) None of these

**Common Data Questions Q.114-15\*.**

The transistor in the amplifier circuit shown in Figure is biased at

**NOTES**

$$I_C = 1 \text{ mA}$$

Use  $V_T = kT/q = 26 \text{ mV}$ ,  $\beta_0 = 200$ ,  $r_b = 0$ , and  $r_o \rightarrow \infty$

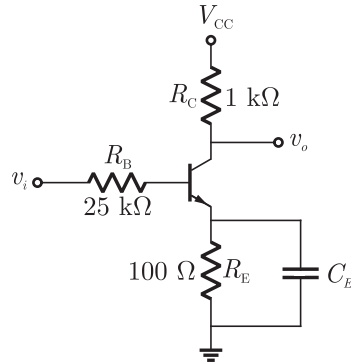

**MCQ 8.114**

Small-signal mid-band voltage gain  $v_o/v_i$  is

- (A)  $-8$  (B)  $38.46$   
 (C)  $-6.62$  (D)  $-1$

**MCQ 8.115**

What is the required value of  $C_E$  for the circuit to have a lower cut-off frequency of 10 Hz

- (A)  $0.15 \text{ mF}$  (B)  $1.59 \text{ mF}$   
 (C)  $5 \text{ } \mu\text{F}$  (D)  $10 \text{ } \mu\text{F}$

**Common Data Questions Q.116-117\***

For the circuit shown in figure

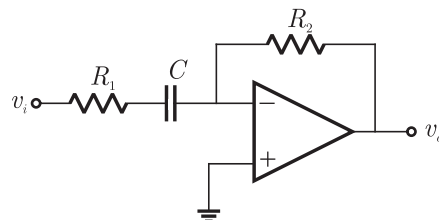

**MCQ 8.116**

The circuit shown is a

- (A) Low pass filter                      (B) Band pass filter  
(C) Band Reject filter                  (D) High pass filter

**MCQ 8.117**

If the above filter has a 3 dB frequency of 1 kHz, a high frequency input resistance of  $100\text{ k}\Omega$  and a high frequency gain of magnitude 10. Then values of  $R_1$ ,  $R_2$  and  $C$  respectively are :-

- (A)  $100\text{ k}\Omega$ ,  $1000\text{ k}\Omega$ ,  $15.9\text{ nF}$   
(B)  $10\text{ k}\Omega$ ,  $100\text{ k}\Omega$ ,  $0.11\text{ }\mu\text{F}$   
(C)  $100\text{ k}\Omega$ ,  $1000\text{ k}\Omega$ ,  $15.9\text{ nF}$   
(D) none of these

\*\*\*\*\*

**NOTES**

## SOLUTION

### SOL 8.1

Since the op-amp is ideal

$$v_+ = v_- = +2 \text{ volt}$$

By writing node equation

$$\frac{v_- - 0}{R} + \frac{v_- - v_o}{2R} = 0$$

$$\frac{2}{R} + \frac{(2 - v_o)}{2R} = 0$$

$$4 + 2 - v_o = 0$$

$$v_o = 6 \text{ volt}$$

Hence (B) is correct option.

### SOL 8.2

Given circuit is,

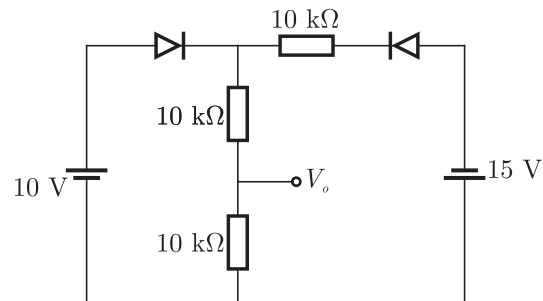

We can observe that diode  $D_2$  is always off, whether  $D_1$  is on or off. So equivalent circuit is.

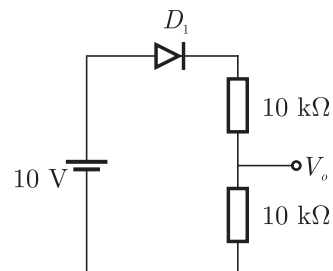



**NOTES**

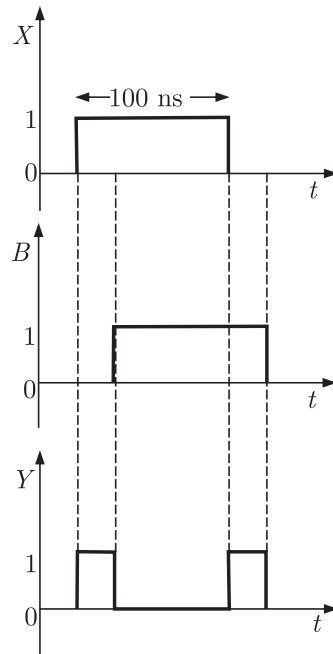

Hence (A) is correct option.

**SOL 8.5**

CALL, Address performs two operations

(1) PUSH PC  $\Rightarrow$  Save the contents of PC (Program Counter) into stack.

$$SP = SP - 2 \text{ (decrement)}$$

$$((SP)) \leftarrow (PC)$$

(2) Addr stored in PC.

$$(PC) \leftarrow \text{Addr}$$

Hence (D) is correct option.

**SOL 8.6**

Function  $F$  can be minimized by grouping of all 1's in K-map as following.

	$YZ$	00	01	11	10
$X$	0	1	1	1	0
	1	0	0	1	0

$$F = \bar{X} \bar{Y} + YZ$$

Hence (B) is correct option.

**SOL 8.7**

Since  $F = \bar{X} \bar{Y} + YZ$

In option (D)

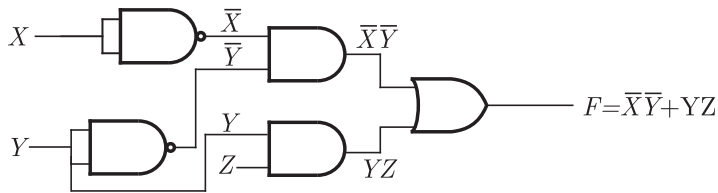

Hence (D) is correct option.

**SOL 8.8**

Figure shows current characteristic of diode during switching.

Hence (A) is correct option.

**SOL 8.9**

The increasing order of speed is as following

Magnetic tape > CD-ROM > Dynamic RAM > Cache Memory > Processor register

Hence (B) is correct option.

**SOL 8.10**

Equivalent circuit of given amplifier

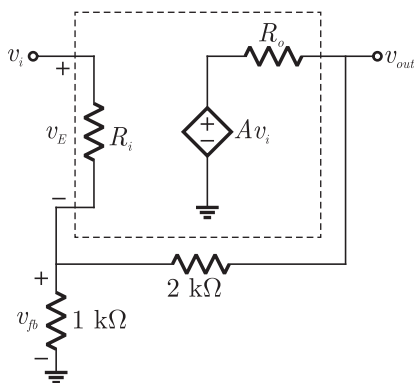

Feedback samples output voltage and adds a negative feedback

**SOL 8.14**

For the given instruction set,

$$\text{XRA } A \Rightarrow \text{XOR } A \text{ with } A \Rightarrow A = 0$$

$$\text{MVI } B, \text{F0 H} \Rightarrow B = \text{F0 H}$$

$$\text{SUB } B \Rightarrow A = A - B$$

$$A = 00000000$$

$$B = 11110000$$

$$2\text{'s complement of } (-B) = \underline{00010000}$$

$$A + (-B) = A - B = 00010000 \\ = 10 \text{ H}$$

Hence (D) is correct option.

**SOL 8.15**

This is a schmitt trigger circuit, output can takes two states only.

$$V_{OH} = +6 \text{ volt}$$

$$V_{OL} = -3 \text{ volt}$$

Threshold voltages at non-inverting terminals of op-amp is given as

$$\frac{V_{TH} - 6}{2} + \frac{V_{TH} - 0}{1} = 0$$

$$3V_{TH} - 6 = 0$$

$$V_{TH} = 2 \text{ V (Upper threshold)}$$

Similarly

$$\frac{V_{TL} - (-3)}{2} + \frac{V_{TL}}{1} = 0$$

$$3V_{TL} + 3 = 0$$

$$V_{TL} = -1 \text{ V (Lower threshold)}$$

For  $V_{in} < 2 \text{ Volt}, V_0 = +6 \text{ Volt}$

$V_{in} > 2 \text{ Volt}, V_0 = -3 \text{ Volt}$

$V_{in} < -1 \text{ Volt } V_0 = +6 \text{ Volt}$

$V_{in} > -1 \text{ Volt } V_0 = -3 \text{ Volt}$

**NOTES**

Output waveform

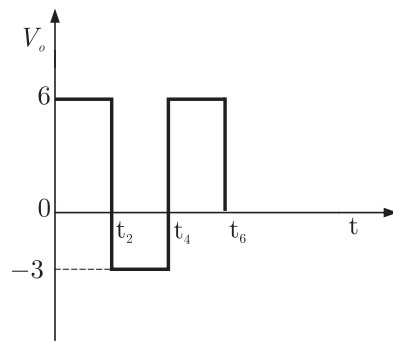

Hence(D) is correct option.

**SOL 8.16**

Assume the diode is in reverse bias so equivalent circuit is

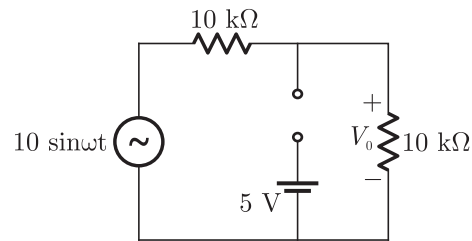

Output voltage  $V_0 = \frac{10 \sin \omega t}{10 + 10} \times 10 = 5 \sin \omega t$

Due to resistor divider, voltage across diode  $V_D < 0$  (always). So it is in reverse bias for given input.

Output,  $V_0 = 5 \sin \omega t$

Hence (A) is correct option.

**SOL 8.17**

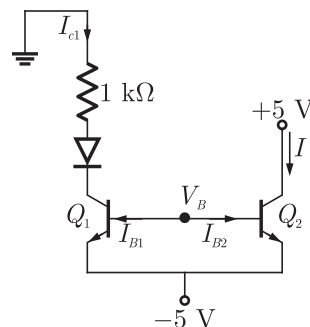

**NOTES**

**SOL 8.19**

Let input  $V_{in}$  is a sine wave shown below

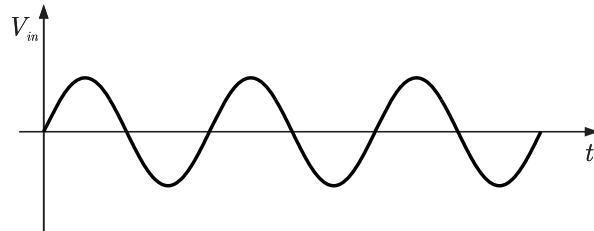

According to given transfer characteristics of rectifiers output of rectifier P is.

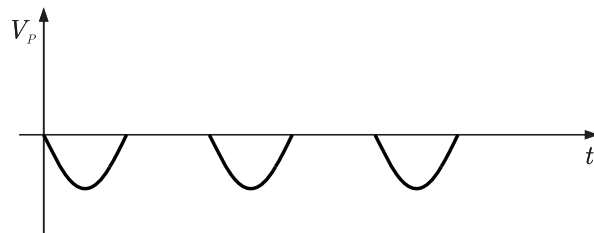

Similarly output of rectifier Q is

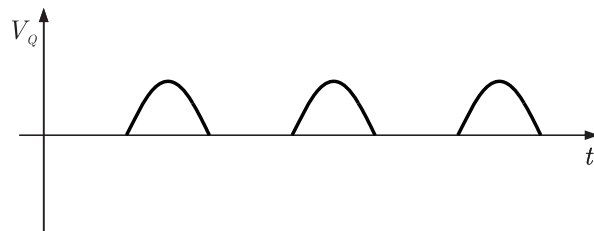

Output of a full wave rectifier is given as

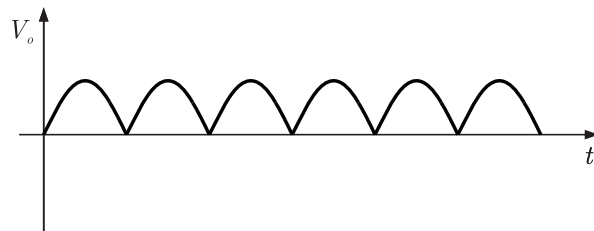

To get output  $V_0$

$$V_0 = K(-V_P + V_Q) \quad K - \text{gain of op-amp}$$

So, P should be connected at inverting terminal of op-amp and Q with non-inverting terminal.

**SOL 8.20**

**SOL 8.21**

For low frequencies,

$$\omega \rightarrow 0, \text{ so } \frac{1}{\omega C} \rightarrow \infty$$

Equivalent circuit is,

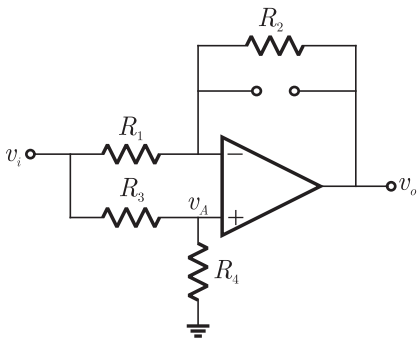

By applying node equation at positive and negative input terminals of op-amp.

$$\frac{v_A - v_i}{R_1} + \frac{v_A - v_o}{R_2} = 0$$

$$2v_A = v_i + v_o, \quad \therefore R_1 = R_2 = R_A$$

Similarly,

$$\frac{v_A - v_i}{R_3} + \frac{v_A - 0}{R_4} = 0$$

$$2v_A = v_{in}, \quad \therefore R_3 = R_4 = R_B$$

So,  $v_o = 0$

It will stop low frequency signals.

For high frequencies,

$$\omega \rightarrow \infty, \text{ then } \frac{1}{\omega C} \rightarrow 0$$

Equivalent circuit is,

Solving from K- map

	$YZ$	$\bar{Y}\bar{Z}$	$\bar{Y}Z$	$YZ$	$Y\bar{Z}$
$X$		$\bar{X}$	$X$		
$\bar{X}$			1	1	
$X$		1			1

$$F = \bar{X}Z + \bar{Y}Z + XY\bar{Z}$$

In POS form

$$F = (Y + Z)(X + Z)(\bar{X} + \bar{Y} + \bar{Z})$$

since all outputs are active low so each input in above expression is complemented

$$F = (\bar{Y} + \bar{Z})(\bar{X} + \bar{Z})(X + Y + Z)$$

Hence (B) is correct option.

**SOL 8.24**

Given that

$$SP = 2700 \text{ H}$$

$$PC = 2100 \text{ H}$$

$$HL = 0000 \text{ H}$$

Executing given instruction set in following steps,

DAD SP  $\Rightarrow$  Add register pair (SP) to HL register

$$HL = HL + SP$$

$$HL = 0000 \text{ H} + 2700 \text{ H}$$

$$HL = 2700 \text{ H}$$

PCHL  $\Rightarrow$  Load program counter with HL contents

$$PC = HL = 2700 \text{ H}$$

So after execution contents are,

$$PC = 2700 \text{ H}, HL = 2700 \text{ H}$$

Hence (B) is correct option.

**SOL 8.25**

If transistor is in normal active region, base current can be calculated as following,

By applying KVL for input loop,

$$10 - I_C(1 \times 10^3) - 0.7 - 270 \times 10^3 I_B = 0$$

$$\beta I_B + 270 I_B = 9.3 \text{ mA}, \quad \therefore I_C = \beta I_B$$

$$I_B(\beta + 270) = 9.3 \text{ mA}$$

**NOTES**

$$I_B = \frac{9.3 \text{ mA}}{270 + 100} = 0.025 \text{ mA}$$

In saturation, base current is given by,

$$10 - I_C(1) - V_{CE} - I_E(1) = 0$$

$$\frac{10}{2} = I_{C(\text{sat})} \quad I_C \simeq I_E$$

$$I_{C(\text{sat})} = 5 \text{ mA}$$

$$V_{CE} \simeq 0$$

$$I_{B(\text{sat})} = \frac{I_{C(\text{sat})}}{\beta}$$

$$= \frac{5}{100} = .050 \text{ mA}$$

$I_B < I_{B(\text{sat})}$ , so transistor is in forward active region.  
Hence (D) is correct option.

**SOL 8.26**

In the circuit

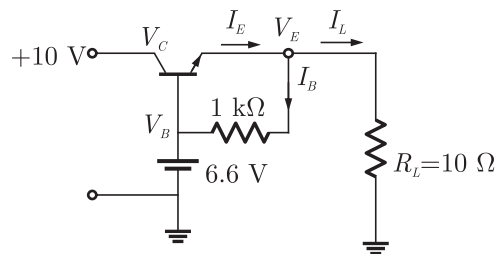

We can analyze that the transistor is operating in active region.

$$V_{BE(\text{ON})} = 0.6 \text{ volt}$$

$$V_B - V_E = 0.6$$

$$6.6 - V_E = 0.6$$

$$V_E = 6.6 - 0.6 = 6 \text{ volt}$$

At emitter (by applying KCL),

$$I_E = I_B + I_L$$

$$I_E = \frac{6 - 6.6}{1 \text{ k}\Omega} + \frac{6}{10 \Omega} \simeq 0.6 \text{ amp}$$

$$V_{CE} = V_C - V_E = 10 - 6 = 4 \text{ volt}$$

Power dissipated in transistor is given by.

$$P_T = V_{CE} \times I_C$$

$$= 4 \times 0.6$$

$$= 2.4 \text{ W} \quad \therefore I_C \simeq I_E = 0.6 \text{ amp}$$

Hence (B) is correct option.



**NOTES**

$V_{CC} \rightarrow$  supply voltage  
 here  $V_P = 7$  volt,  $V_{CC} = 10$  volt

so, 
$$\eta = \frac{\pi}{4} \times \frac{7}{10} \times 100 = 54.95\% \simeq 55\%$$

**SOL 8.30**

In the circuit the capacitor starts charging from 0 V (as switch was initially closed) towards a steady state value of 20 V.

for  $t < 0$  (initial)

for  $t \rightarrow \infty$  (steady state)

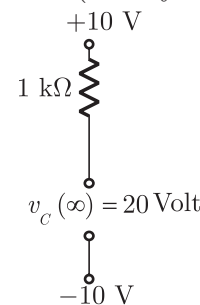
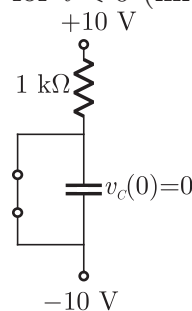

So at any time  $t$ , voltage across capacitor (i.e. at inverting terminal of op-amp) is given by

$$v_c(t) = v_c(\infty) + [v_c(0) - v_c(\infty)] e^{-\frac{t}{RC}}$$

$$v_c(t) = 20(1 - e^{-\frac{t}{RC}})$$

Voltage at positive terminal of op-amp

$$\frac{v_+ - v_{out}}{10} + \frac{v_+ - 0}{100} = 0$$

$$v_+ = \frac{10}{11} v_{out}$$

Due to zener diodes,  $-5 \leq v_{out} \leq +5$

So, 
$$v_+ = \frac{10}{11}(5) \text{ V}$$

Transistor form  $-5$  V to  $+5$  V occurs when capacitor charges upto  $v_+$ .

So 
$$20(1 - e^{-t/RC}) = \frac{10 \times 5}{11}$$

$$1 - e^{-t/RC} = \frac{5}{22}$$

$$\frac{17}{22} = e^{-t/RC}$$

$$t = RC \ln\left(\frac{22}{17}\right) = 1 \times 10^3 \times .01 \times 10^{-6} \times 0.257$$

$$= 2.57 \mu\text{sec}$$

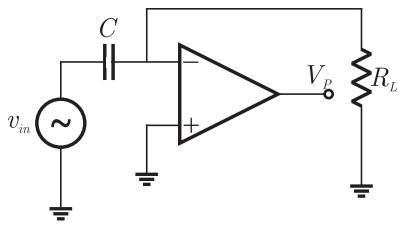

Since there is no feed back to the op-amp and op-amp has a high open loop gain so it goes in saturation. Input is applied at inverting terminal so.

$$V_P = -V_{CC} = -12 \text{ V}$$

In negative half cycle of input, diode  $D_1$  is in forward bias and equivalent circuit is shown below.

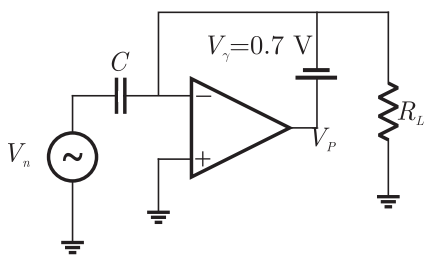

$$\text{Output } V_P = V_\gamma + V$$

Op-amp is at virtual ground so  $V_+ = V = 0$  and  $V_P = V_\gamma = 0.7 \text{ V}$

Voltage wave form at point P is

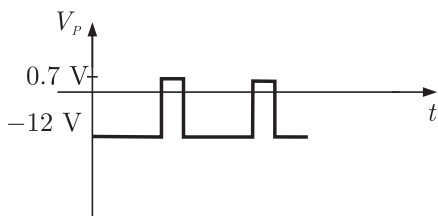

Hence (D) is correct option.

**SOL 8.35**

In the circuit when  $V_i < 10 \text{ V}$ , both  $D_1$  and  $D_2$  are off.

So equivalent circuit is,

**NOTES**

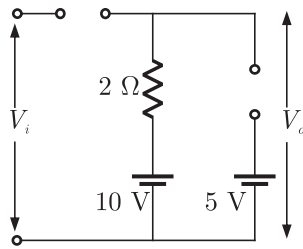

Output,  $V_o = 10$  volt

When  $V_i > 10$  V ( $D_1$  is in forward bias and  $D_2$  is off)  
 So the equivalent circuit is,

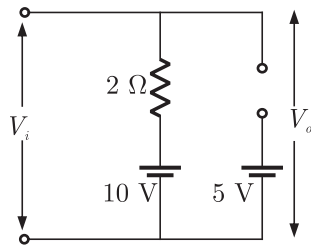

Output,  $V_o = V_i$

Transfer characteristic of the circuit is

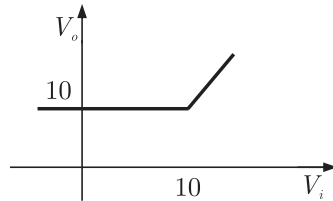

Hence (A) is correct option.

**SOL 8.36**

Assume that BJT is in active region, thevenin equivalent of input circuit is obtained as

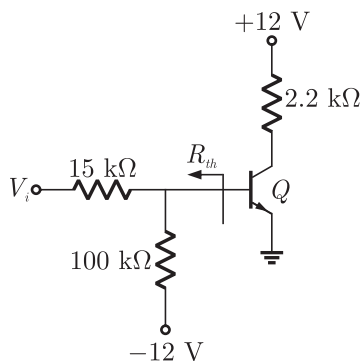

**NOTES**

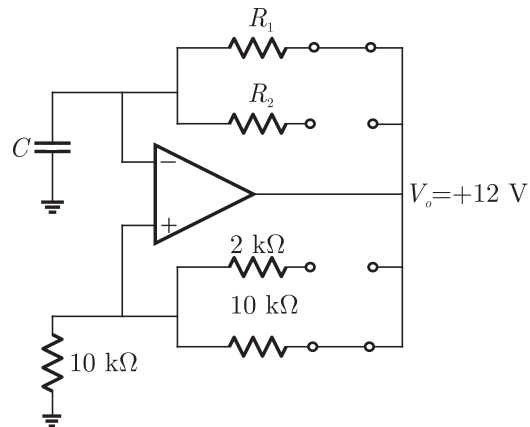

writing node equation at positive terminal of op-amp

$$\frac{V_{th} - 12}{10} + \frac{V_{th} - 0}{10} = 0$$

$$V_{th} = 6\text{ volt (Positive threshold)}$$

So, the capacitor will charge upto 6 volt.

When output  $V_o = -12\text{ V}$ , the equivalent circuit is.

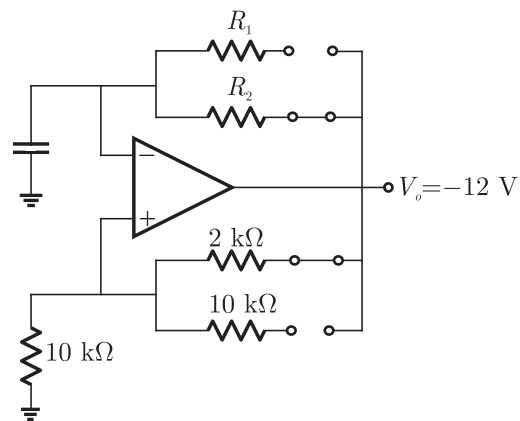

node equation

$$\frac{V_{th} + 12}{2} + \frac{V_{th} - 0}{10} = 0$$

$$5V_{th} + 60 + V_{th} = 0$$

$$V_{th} = -10\text{ volt (negative threshold)}$$

So the capacitor will discharge upto  $-10$  volt.

At terminal P voltage waveform is.

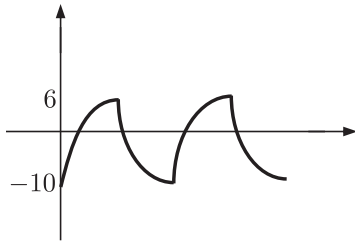

Hence (C) is correct option.

**SOL 8.38**

**SOL 8.39**

**SOL 8.40**

Function  $F$  can be obtain as,

$$\begin{aligned}
 F &= I_0 \bar{S}_1 \bar{S}_0 + I_1 \bar{S}_1 S_0 + I_2 S_1 \bar{S}_0 + I_3 S_1 S_0 \\
 F &= \bar{A} \bar{B} \bar{C} + \bar{A} \bar{B} C + 1 \cdot B \bar{C} + 0 \cdot BC \\
 &= \bar{A} \bar{B} \bar{C} + \bar{A} \bar{B} C + B \bar{C} \\
 &= \bar{A} \bar{B} \bar{C} + \bar{A} \bar{B} C + B \bar{C} (A + \bar{A}) \\
 &= \bar{A} \bar{B} \bar{C} + \bar{A} \bar{B} C + A B \bar{C} + \bar{A} B \bar{C} \\
 F &= \Sigma(1, 2, 4, 6)
 \end{aligned}$$

Hence (A) is correct option.

**SOL 8.41**

MVI H and MVI L stores the value 255 in H and L registers. DCR L decrements L by 1 and JNZ checks whether the value of L is zero or not. So DCR L executed 255 times till value of L becomes '0'.

Then DCR H will be executed and it goes to 'Loop' again, since L is of 8 bit so no more decrement possible and it terminates.

Hence (A) is correct option.

**SOL 8.42**

XCHG  $\Rightarrow$  exchange the contain of DE register pair with HL pair  
 So now addresses of memory locations are stored in HL pair.

INR M  $\Rightarrow$  Increment the contents of memory whose address is

**NOTES**

So,  $V_{ab} = 0$

Hence (D) is correct option.

**SOL 8.46**

Let the present state is  $Q(t)$ , so input to D-flip flop is given by,

$$D = Q(t) \oplus X$$

Next state can be obtained as,

$$Q(t+1) = D$$

$$Q(t+1) = Q(t) \oplus X$$

$$Q(t+1) = Q(t)\bar{X} + \bar{Q}(t)X$$

$$Q(t+1) = \bar{Q}(t), \text{ if } X = 1$$

and  $Q(t+1) = Q(t), \text{ if } X = 0$

So the circuit behaves as a T flip flop.

Hence (C) is correct option.

**SOL 8.47**

Since the transistor is operating in active region.

$$I_E \approx \beta I_B$$

$$I_B = \frac{I_E}{\beta}$$

$$= \frac{1 \text{ mA}}{100} = 10 \mu\text{A}$$

Hence (B) is correct option.

**SOL 8.48**

Gain of the inverting amplifier is given by,

$$A_v = -\frac{R_F}{R_1}$$

$$A_v = -\frac{1 \times 10^6}{R_1}, \quad R_F = 1 \text{ M}\Omega$$

$$R_1 = -\frac{1 \times 10^6}{A_v}$$

$A_v = -10$  to  $-25$  so value of  $R_1$

$$R_1 = \frac{10^6}{10} = 100 \text{ k}\Omega \quad \text{for } A_v = -10$$

$$R_1' = \frac{10^6}{25} = 40 \text{ k}\Omega \quad \text{for } A_v = -25$$

**NOTES**

$R_1$  should be as large as possible so  $R_1 = 100 \text{ k}\Omega$   
Hence (C) is correct option.

**SOL 8.49**

Direct coupled amplifiers or DC-coupled amplifiers provides gain at dc or very low frequency also.  
Hence (B) is correct option.

**SOL 8.50**

Since there is no feedback in the circuit and ideally op-amp has a very high value of open loop gain, so it goes into saturation (ouput is either  $+V$  or  $-V$ ) for small values of input.  
The input is applied to negative terminal of op-amp, so in positive half cycle it saturates to  $-V$  and in negative half cycle it goes to  $+V$ .  
Hence (C) is correct option.

**SOL 8.51**(check)

From the given input output waveforms truth table for the circuit is drawn as

$X_1$	$X_2$	Q
1	0	1
0	0	1
0	1	0

In option (A), for  $X_1 = 1, Q = 0$  so it is eliminated.  
In option (C), for  $X_1 = 0, Q = 0$  (always), so it is also eliminated.  
In option (D), for  $X_1 = 0, Q = 1$ , which does not match the truth table.  
Only option (B) satisfies the truth table.  
Hence (B) is correct option.

**SOL 8.52**

In the given circuit NMOS  $Q_1$  and  $Q_3$  makes an inverter circuit.  $Q_4$  and  $Q_5$  are in parallel works as an OR circuit and  $Q_2$  is an output inverter.

So output is

$$Q = \overline{\overline{X_1} + \overline{X_2}} = X_1 \cdot \overline{X_2}$$

Hence (D) is correct option.

**NOTES**

**SOL 8.56**

Given circuit,

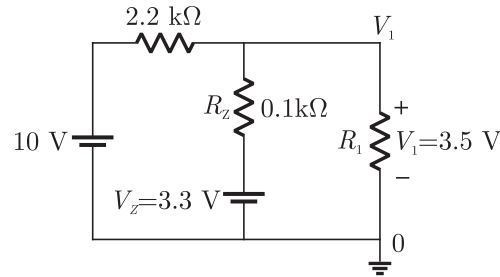

In the circuit

$$V_1 = 3.5 \text{ V (given)}$$

Current in zener is.

$$I_Z = \frac{V_1 - V_Z}{R_Z}$$

$$I_Z = \frac{3.5 - 3.3}{0.1 \times 10^3}$$

$$I_Z = 2 \text{ mA}$$

Hence (C) is correct option.

**SOL 8.57**

This is a current mirror circuit. Since  $V_{BE}$  is the same in both devices, and transistors are perfectly matched, then

$$I_{B1} = I_{B2} \text{ and } I_{C1} = I_{C2}$$

From the circuit we have,

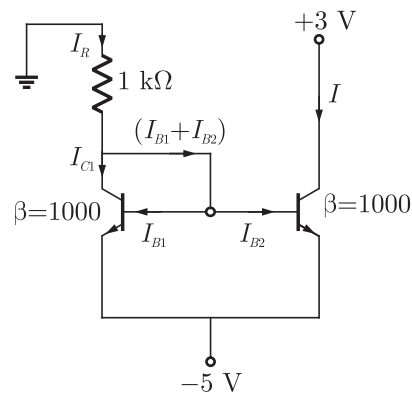

$$I_R = I_{C1} + I_{B1} + I_{B2}$$

$$I_R = I_{C1} + 2I_{B2}$$

$$\therefore I_{B1} = I_{B2}$$



$$I_R = I_{C2} + \frac{2I_{C2}}{\beta} \quad \because I_{C1} = I_{C2}, I_{C2} = \beta I_{B2}$$

$$I_R = I_{C2} \left( 1 + \frac{2}{\beta} \right)$$

$$I_{C2} = I = \frac{I_R}{\left( 1 + \frac{2}{\beta} \right)}$$

$I_R$  can be calculate as

$$I_R = \frac{-5 + 0.7}{1 \times 10^3} = -4.3 \text{ mA}$$

So,

$$I = \frac{4.3}{\left( 1 + \frac{2}{100} \right)} \simeq 4.3 \text{ mA}$$

Hence (C) is correct option.

**SOL 8.58**

The small signal equivalent circuit of given amplifier

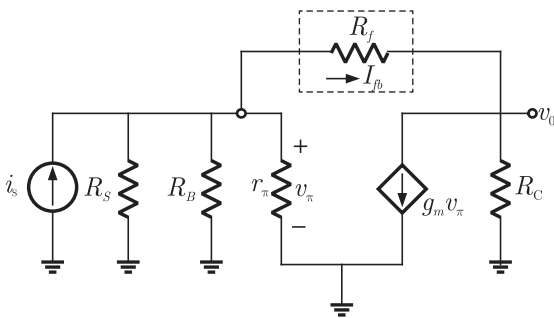

Here the feedback circuit samples the output voltage and produces a feed back current  $I_{fb}$  which is in shunt with input signal. So this is a shunt-shunt feedback configuration.

Hence (B) is correct option.

**SOL 8.59**

In the given circuit output is stable for both 1 or 0. So it is a bistable multi-vibrator.

Hence (A) is correct option.

**NOTES**

**SOL 8.64**

**SOL 8.65**

If op-amp is ideal, no current will enter in op-amp. So current  $i_x$  is

$$i_x = \frac{v_x - v_y}{1 \times 10^6} \quad \dots(1)$$

$$v_+ = v_- = v_x \quad (\text{ideal op-amp})$$

$$\frac{v_x - v_y}{100 \times 10^3} + \frac{v_x - 0}{10 \times 10^3} = 0$$

$$v_x - v_y + 10v_x = 0$$

$$11v_x = v_y \quad \dots(2)$$

For equation (1) & (2)

$$i_x = \frac{v_x - 11v_x}{1 \times 10^6}$$

$$i_x = -\frac{10v_x}{10^6}$$

Input impedance of the circuit.

$$R_{in} = \frac{v_x}{i_x} = -\frac{10^6}{10} = -100 \text{ k}\Omega$$

Hence (B) is correct option.

**SOL 8.66**

Given Boolean expression,

$$Y = (\bar{A} \cdot BC + D)(\bar{A} \cdot D + \bar{B} \cdot \bar{C})$$

$$Y = (\bar{A} \cdot BCD) + (\bar{A}BC \cdot \bar{B} \cdot \bar{C}) + (\bar{A}D) + \bar{B} \bar{C} D$$

$$Y = \bar{A} BCD + \bar{A}D + \bar{B} \bar{C} D$$

$$Y = \bar{A}D(BC + 1) + \bar{B} \bar{C} D$$

$$Y = \bar{A}D + \bar{B} \bar{C} D$$

Hence (A) is correct option.

**SOL 8.67**

In the given circuit, output is given as.

$$Y = (A_0 \oplus B_0) \odot (A_1 \oplus B_1) \odot (A_2 \oplus B_2) \odot (A_3 \oplus B_3)$$

For option (A)

$$Y = (1 \oplus 1) \odot (0 \oplus 0) \odot (1 \oplus 1) \odot (0 \oplus 0)$$

$$= 0 \odot 0 \odot 0 \odot 0$$

$$= 1$$

**NOTES**

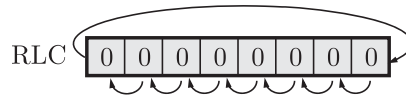
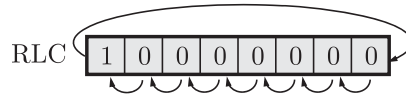
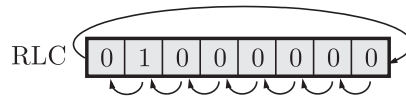
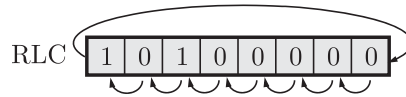
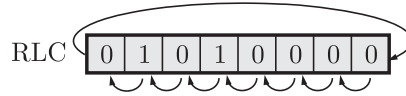
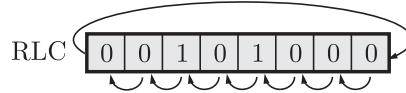
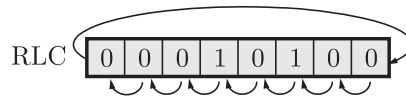

So total no. of instruction cycles are

$$n = 1 + 6 + 5 + 1$$

$$= 13$$

Hence (C) is correct option.

**SOL 8.70**

In the given circuit

$$V_i = 0 \text{ V}$$

So, transistor  $Q_1$  is in cut-off region and  $Q_2$  is in saturation.

$$5 - I_C R_C - V_{CE(\text{sat})} - 1.25 = 0$$

$$5 - I_C R_C - 0.1 - 1.25 = 0$$

$$5 - I_C R_C = 1.35$$

$$V_0 = 1.35$$

$$\{\because V_0 = 5 - I_C R_C$$

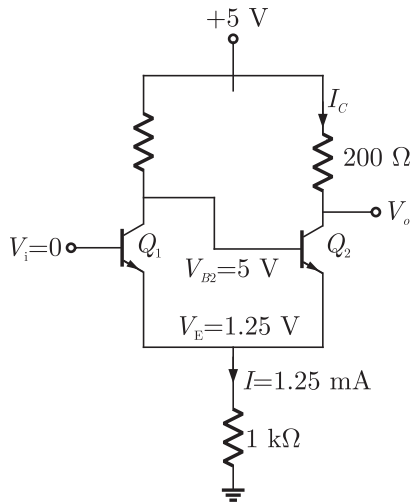

Hence (B) is correct option.

**SOL 8.71**

Since there exists a drain current for zero gate voltage ( $V_{GS} = 0$ ), so it is a depletion mode device.

$I_D$  increases for negative values of gate voltages so it is a  $p$ -type depletion mode device.

Hence (C) is correct option.

**SOL 8.72**

Applying KVL in input loop,

$$4 - (33 \times 10^3) I_B - V_{BE} - (3.3 \times 10^3) I_E = 0$$

$$4 - (33 \times 10^3) I_B - 0.7 - (3.3 \times 10^3) (h_{fe} + 1) I_B = 0$$

$$\therefore I_E = (h_{fe} + 1) I_B$$

$$3.3 = [(33 \times 10^3) + (3.3 \times 10^3) (99 + 1)] I_B$$

$$I_B = \frac{3.3}{33 \times 10^3 + 3.3 \times 10^3 \times 100}$$

$$I_C = h_{fe} I_B$$

$$I_C = \frac{99 \times 3.3}{[0.33 + 3.3] \times 100} \text{ mA}$$

$$I_C = \frac{3.3}{0.33 + 3.3} \text{ mA}$$

Hence (B) is correct option.

P	Q	$C_{in}$	Sum
0	0	0	0
0	0	1	1
0	1	0	1
0	1	1	0
1	0	0	1
1	0	1	0
1	1	0	0
1	1	1	1

Sum is.

$$\text{Sum} = \overline{P} \overline{Q} C_{in} + \overline{P} Q \overline{C_{in}} + P \overline{Q} \overline{C_{in}} + P Q C_{in}$$

Output of MUX can be written as

$$F = \overline{P} \overline{Q} \cdot I_0 + \overline{P} Q \cdot I_1 + P \overline{Q} \cdot I_2 + P Q \cdot I_3$$

Inputs are,

$$I_0 = C_{in}, \quad I_1 = \overline{C_{in}}, \quad I_2 = \overline{C_{in}}, \quad I_3 = C_{in}$$

Hence (C) is correct option.

**SOL 8.75**

Program counter contains address of the instruction that is to be executed next.

Hence (D) is correct option.

**SOL 8.76**

For a  $n$ -channel enhancement mode MOSFET transition point is given by,

$$V_{DS(\text{sat})} = V_{GS} - V_{TH} \quad \because V_{TH} = 2 \text{ volt}$$

$$V_{DS(\text{sat})} = V_{GS} - 2$$

From the circuit,

$$V_{DS} = V_{GS}$$

So

$$V_{DS(\text{sat})} = V_{DS} - 2 \Rightarrow V_{DS} = V_{DS(\text{sat})} + 2$$

$$V_{DS} > V_{DS(\text{sat})}$$

Therefore transistor is in saturation region and current equation is given by.

$$I_D = K(V_{GS} - V_{TH})^2$$

$$4 = K(V_{GS} - 2)^2$$

**NOTES**

$V_{GS}$  is given by

$$\begin{aligned} V_{GS} = V_{DS} &= 10 - I_D R_D \\ &= 10 - 4 \times 1 = 6 \text{ Volt} \end{aligned}$$

So,

$$\begin{aligned} 4 &= K(6 - 2)^2 \\ K &= \frac{1}{4} \end{aligned}$$

Now  $R_D$  is increased to  $4 \text{ k}\Omega$ , Let current is  $I'_D$  and voltages are  $V'_{DS} = V'_{GS}$

Applying current equation.

$$\begin{aligned} I'_D &= K(V'_{GS} - V_{TH})^2 \\ I'_D &= \frac{1}{4}(V'_{GS} - 2)^2 \end{aligned}$$

$$\begin{aligned} V'_{GS} = V'_{DS} &= 10 - I'_D \times R'_D \\ &= 10 - 4I'_D \end{aligned}$$

So,

$$\begin{aligned} 4I'_D &= (10 - 4I'_D - 2)^2 \\ 4I'_D &= (8 - 4I'_D)^2 \\ 4I'_D &= 16(2 - I'_D)^2 \\ I'_D &= 4(4 + I'^2_D - 4I'_D) \\ 4I'^2_D - 17 + 16 &= 0 \\ I'^2_D &= 2.84 \text{ mA} \end{aligned}$$

Hence (A) is correct option.

**SOL 8.77**

Let the voltages at input terminals of op-amp are  $v$  and  $v_+$  respectively.

So,  $v_+ = v = 0$  (ideal op-amp)

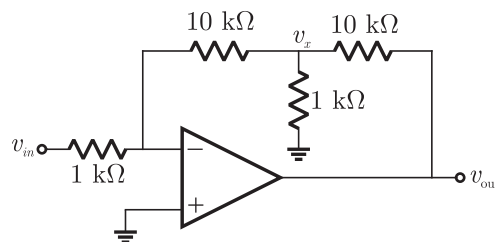

Applying node equation at negative terminal of op-amp,

$$\frac{0 - v_{in}}{1} + \frac{0 - v_x}{10} = 0 \quad \dots(1)$$

**NOTES**

Applying KVL

$$V_{in} - 10I + 4 - 10I = 0$$

$$\frac{V_{in} + 4}{20} = I$$

$V_{in} = -10$  V (Maximum value in negative half cycle)

So, 
$$I = \frac{-10 + 4}{20} = -\frac{3}{10} \text{ mA}$$

$$\frac{V_{in} - V_{out}}{10} = I$$

$$\frac{-10 - V_{out}}{10} = -\frac{3}{10}$$

$$V_{out} = -(10 - 3)$$

$$V_{out} = -7 \text{ volt}$$

Hence (D) is correct option.

**SOL 8.79**

In the circuit, the capacitor charges through resistor ( $R_A + R_B$ ) and discharges through  $R_B$ . Charging and discharging time is given as.

$$T_C = 0.693(R_A + R_B)C$$

$$T_D = 0.693 R_B C$$

Frequency  $f = \frac{1}{T} = \frac{1}{T_D + T_C} = \frac{1}{0.693(R_A + 2R_B)C}$

$$\frac{1}{0.693(R_A + 2R_B) \times 10 \times 10^{-9}} = 10 \times 10^3$$

$$14.4 \times 10^3 = R_A + 2R_B \quad \dots(1)$$

$$\text{duty cycle} = \frac{T_C}{T} = 0.75$$

$$\frac{0.693(R_A + R_B)C}{0.693(R_A + 2R_B)C} = \frac{3}{4}$$

$$4R_A + 4R_B = 3R_A + 6R_B$$

$$R_A = 2R_B \quad \dots(2)$$

From (1) and (2)

$$2R_A = 14.4 \times 10^3$$

$$R_A = 7.21 \text{ k}\Omega$$

and

$$R_B = 3.60 \text{ k}\Omega$$

Hence (C) is correct option.

**SOL 8.80**

Given boolean expression can be written as,

$$\begin{aligned}
 F &= \overline{X}Y\overline{Z} + \overline{X}\overline{Y}Z + X\overline{Y}Z + XY\overline{Z} + XYZ \\
 &= \overline{X}Y\overline{Z} + \overline{Y}Z(X + \overline{X}) + XY(\overline{Z} + Z) \\
 &= \overline{X}Y\overline{Z} + \overline{Y}Z + XY \\
 &= \overline{Y}Z + Y(X + \overline{X}\overline{Z}) \quad \because A + BC = (A + B)(A + C) \\
 &= \overline{Y}Z + Y(X + \overline{X})(X + \overline{Z}) \\
 &= \overline{Y}Z + Y(X + \overline{Z}) \\
 &= \overline{Y}Z + YX + Y\overline{Z}
 \end{aligned}$$

Hence (B) is correct option.

**SOL 8.81**

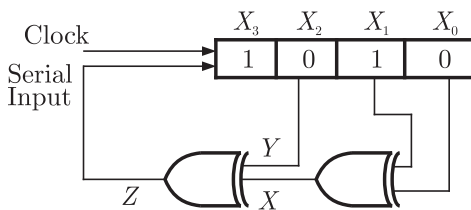

$$X = X_1 \oplus X_0, Y = X_2$$

$$\text{Serial Input } Z = X \oplus Y = [X_1 \oplus X_0] \oplus X_2$$

Truth table for the circuit can be obtain as.

Clock pulse	Serial Input	Shif register
Initially	1	1010
1	0	1101
2	0	0110
3	0	0011
4	1	0001
5	0	1000
6	1	0100
7	1	1010

So after 7 clock pulses contents of the shift register is 1010 again.

Hence (B) is correct option.



**SOL 8.84**

Executing all the instructions one by one.

$$\text{LXI H, 1FFE} \Rightarrow \text{H} = (1\text{F})_{\text{H}}, \text{L} = (\text{FE})_{\text{H}}$$

$$\text{MOV B, M} \Rightarrow \text{B} = \text{Memory}[\text{HL}] = \text{Memory}[1\text{FFE}]$$

$$\text{INR L} \Rightarrow \text{L} = \text{L} + (1)_{\text{H}} = (\text{FF})_{\text{H}}$$

$$\text{MOV A, M} \Rightarrow \text{A} = \text{Memory}[\text{HL}] = \text{Memory}[1\text{FFF}]$$

$$\text{ADD B} \Rightarrow \text{A} = \text{A} + \text{B}$$

$$\text{INR L} \Rightarrow \text{L} = \text{L} + (1)_{\text{H}} = (\text{FF})_{\text{H}} + (1)_{\text{H}} = 00$$

$$\text{MOV M, A} \Rightarrow \text{Memory}[\text{HL}] = \text{A}$$

$$\text{Memory}[1\text{F00}] = \text{A}$$

$$\text{XOR A} \Rightarrow \text{A} = \text{A XOR A} \\ = 0$$

So the result of addition is stored at memory address 1F00.

Hence (C) is correct option.

**SOL 8.85**

Let the initial state  $Q(t) = 0$ , So  $D = \bar{Q} = 1$ , the output waveform is.

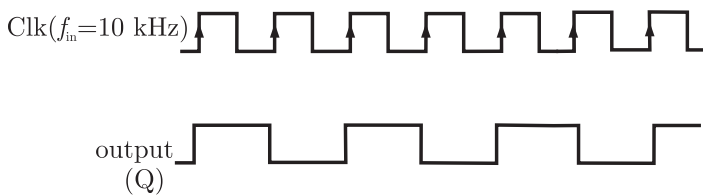

So frequency of the output is,

$$f_{out} = \frac{f_{in}}{2} = \frac{10}{2} = 5 \text{ kHz}$$

Hence (D) is correct option.

**SOL 8.86**

This is a half-wave rectifier circuit, so the DC voltage is given by

$$V_{dc} = \frac{V_m}{\pi}$$

Equivalent circuit with forward resistance is

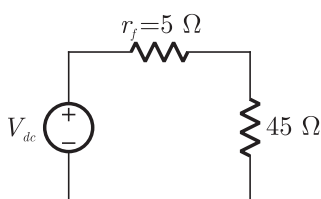

**NOTES**

DC current in the circuit

$$I_{dc} = \frac{\frac{V_m}{\pi}}{r_f + R} = \frac{(V_m/\pi)}{(5 + 45)}$$

$$I_{dc} = \frac{V_m}{50\pi}$$

Hence (A) is correct option.

**SOL 8.87**

In the positive half cycle zener diode ( $D_z$ ) will be in reverse bias (behaves as a constant voltage source) and diode (D) is in forward bias. So equivalent circuit for positive half cycle is.

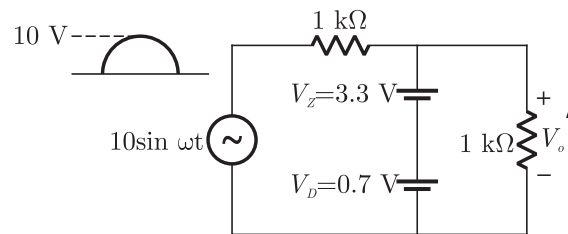

$$\begin{aligned} \text{Output } V_o &= V_D + V_z \\ &= 0.7 + 3.3 \\ &= 4 \text{ Volt} \end{aligned}$$

In the negative half cycle, zener diode ( $D_z$ ) is in forward bias and diode (D) is in reverse bias mode. So equivalent circuit is.

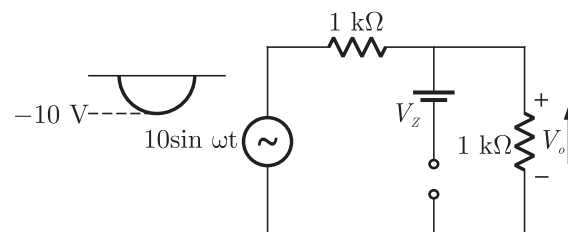

So the peak output is,

$$V_o = \frac{10}{(1 + 1)} \times 1$$

$$V_o = 5 \text{ Volt}$$

Hence (B) is correct option.

**NOTES**

**SOL 8.90**

In the circuit, voltage at positive terminal of op-amp is given by

$$\frac{v_+ - v_o}{10} + \frac{v_+ - 2}{3} = 0$$

$$3(v_+ - v_o) + 10(v_+ - 2) = 0$$

$$13v_+ = 20 + 3v_o$$

Output changes from +15 V to -15 V, when  $v_+ > v_+$

$$v_+ = \frac{20 + (3 \times 15)}{13}$$

$$v_+ = 5 \text{ Volt (for positive half cycle)}$$

Hence (A) is correct option.

**SOL 8.91**

Output for each stage can be obtain as,

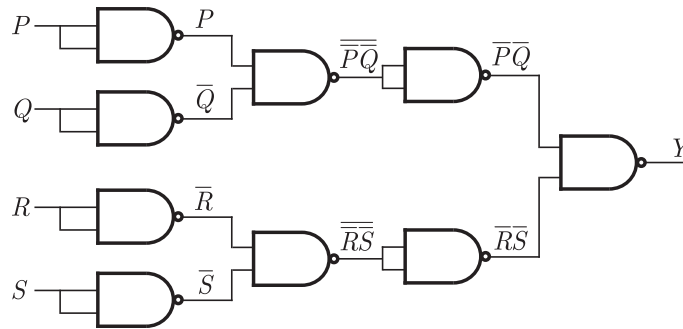

So final output  $Y$  is.

$$Y = \overline{P Q} \cdot \overline{R S}$$

$$Y = \overline{(P + Q) \cdot (R + S)} \quad \because \overline{AB} = \overline{A} + \overline{B}$$

$$Y = P + Q + R + S$$

Hence (B) is correct option.

**SOL 8.92**

We can analyze that the transistor is in active region.

$$I_C = \frac{\beta}{(\beta + 1)} I_E$$

$$I_C = \frac{99}{(99 + 1)} (1 \text{ mA})$$

$$I_C = 0.99 \text{ mA}$$

In the circuit

$$T(j\omega) = \frac{j\omega CR}{1 + j3\omega CR - C^2 R^2 \omega^2}$$

$$= \frac{j\omega CR}{(1 - C^2 R^2 \omega^2) + 3j\omega CR}$$

Hence (A) is correct option.

**SOL 8.96**

Applying Barkhausen criterion of oscillation phase shift will be zero.

$$\angle T(j\omega_0) = 0 \quad \omega_0 \rightarrow \text{frequency of oscillation.}$$

$$1 - C^2 R^2 \omega_0^2 = 0$$

$$\omega_0^2 = \frac{1}{R^2 C^2}$$

$$\omega_0 = \frac{1}{RC}$$

Hence (A) is correct option.

**SOL 8.97**

In figure

$$V_y = \frac{V_0}{R_F + R} R$$

$$|T(j\omega)| = \frac{V_y}{V_0} = \left| \frac{j\omega_0 CR}{1 - \omega_0^2 C^2 R^2 + j3\omega_0 CR} \right|$$

$$\omega = \frac{1}{RC}$$

So, 
$$\frac{V_y}{V_0} = \frac{j}{3j} = \frac{1}{3}$$

$$\frac{R}{R_F + R} = \frac{1}{3}$$

$$R_F = 2R = 2 \times 1 = 2 \text{ k}\Omega$$

Hence (C) is correct option.

**NOTES**

**SOL 8.98**

By writing truth table for the circuit

CLK	$Q_2$	$Q_1$	$Q_0$
Initially	0	0	0
1	0	0	1
2	0	1	0
3	0	1	1
4	1	0	0
	1	0	1

All flip flops are reset. When it goes to state 101, output of NAND gate becomes 0 or  $\overline{CLR} = 0$ , so all FFs are reset. Thus it is modulo 4 counter.

Hence (C) is correct option.

**SOL 8.99**

When the switch is closed (i.e. during  $T_{ON}$ ) the equivalent circuit is

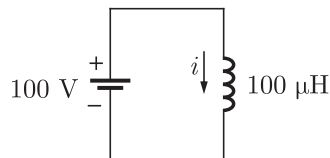

Diode is off during  $T_{ON}$ . writing KVL in the circuit.

$$100 - (100 \times 10^{-6}) \frac{di}{dt} = 0$$

$$\frac{di}{dt} = 10^6$$

$$i = \int 10^6 dt = 10^6 t + i(0)$$

Since initial current is zero  $i(0) = 0$

So, 
$$i = 10^6 t$$

After a duration of  $T_{ON}$  the current will be maximum given as

$$i_{Peak} = 10^6 T_{ON}$$

When the switch is opened (i.e. during  $T_{off}$ ) the equivalent circuit is

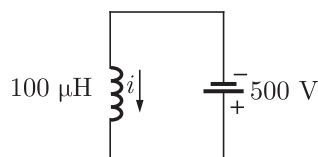

**NOTES**

At  $t = T_{\text{off}}$   

$$V_c = \frac{I}{C} T_{\text{off}}$$

Duty cycle 
$$D = \frac{T_{\text{ON}}}{T_{\text{ON}} + T_{\text{OFF}}} = \frac{T_{\text{ON}}}{T}$$

$$T_{\text{ON}} = DT$$

$$T_{\text{OFF}} = T - T_{\text{ON}} = T - DT$$

So,  

$$V_c = \frac{I}{C} (T - DT)$$

$$= \frac{I}{C} (1 - D) T$$

During  $T_{\text{OFF}}$ , output voltage  $V_0 = 0$  volt.

Hence (C) is correct option.

**SOL 8.101**

When the switch is closed, diode is off and the circuit is

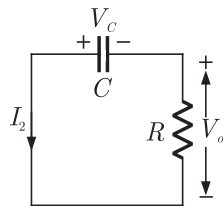

In steady state condition

$$C \frac{dV_c}{dt} = I_2$$

$$I_2 = C \frac{I}{C} \quad \therefore \frac{dV_c}{dt} = \frac{I}{C}$$

$$V_0 = -V_c = -\frac{I}{C} t$$

Average output voltage

$$V_0 = \frac{1}{T} \left[ \int_0^{DT=T_{\text{ON}}} \left( -\frac{I}{C} t \right) dt + \int_0^{T_{\text{OFF}}} 0 dt \right]$$

$$= -\frac{1}{T} \cdot \frac{I}{C} \left[ \frac{t^2}{2} \right]_0^{DT}$$

$$= -\frac{1}{T} \cdot \frac{I}{C} \cdot \frac{D^2 T^2}{2} = -\frac{I D^2}{C} \cdot \frac{T}{2}$$

Hence (B) is correct option.

**SOL 8.102**

Equivalent hybrid circuit of given transistor amplifier when  $R_E$  is by passed is shown below.

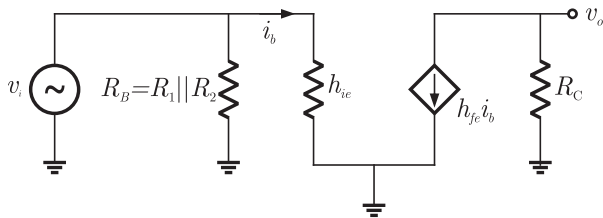

In the circuit

$$i_b = \frac{v_s}{h_{ie}} \quad \dots(1)$$

$$v_o = h_{fe} i_b \cdot R_C = h_{fe} \cdot \frac{v_s}{h_{ie}} \cdot R_C$$

$$\text{Voltage gain } A_{v_1} = \frac{v_o}{v_i} = \frac{h_{fe} R_C}{h_{ie}}$$

Equivalent hybrid circuit when  $R_E$  is not bypassed by the capacitor.

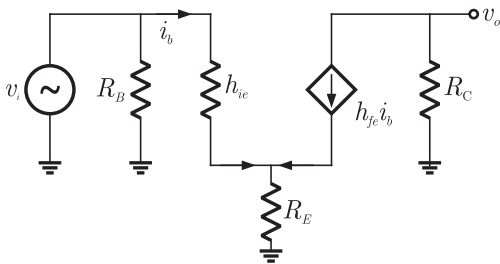

In the circuit

$$v_s = i_b h_{ie} + (i_b + h_{fe} i_b) R_E$$

$$v_s = i_b [h_{ie} + (1 + h_{fe}) R_E] \quad \dots(2)$$

$$v_o = h_{fe} i_b \cdot R_C \quad \dots(3)$$

from equation (2) and (3)

$$v_o = h_{fe} \cdot R_C \frac{v_s}{h_{ie} + (1 + h_{fe}) R_E}$$

Voltage gain

$$A_{v_2} = \frac{v_o}{v_s} = \frac{h_{fe} R_C}{h_{ie} + (1 + h_{fe}) R_E}$$

$$\text{So } \frac{A_{v_1}}{A_{v_2}} = \frac{h_{ie} + (1 + h_{fe}) R_E}{h_{ie}} = 1 + \frac{(1 + h_{fe}) R_E}{h_{ie}}$$

$$A_{v_2} < A_{v_1}$$

Hence (B) is correct option.

**SOL 8.107**

Given circuit is an astable multi vibrator circuit, time period is given as

$$T = 2\tau \ln\left(\frac{1+\beta}{1-\beta}\right), \quad \tau = RC$$

$\beta \rightarrow$  feedback factor

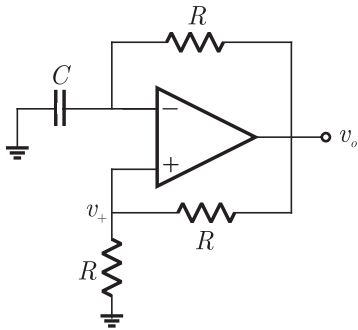

$$\beta = \frac{v_+}{v_o} = \frac{1}{2}$$

So,

$$T = 2\tau \ln\left(\frac{1+\frac{1}{2}}{1-\frac{1}{2}}\right) = 2\tau \ln 3$$

Hence (B) is correct option.

**SOL 8.108**

MVI A, 10 H  $\Rightarrow$  MOV (10)<sub>H</sub> in accumulator

A = (10)<sub>H</sub>

MVI B, 10 H  $\Rightarrow$  MOV (10)<sub>H</sub> in register B

B = (10)<sub>H</sub>

BACK : NOP

ADDB  $\Rightarrow$  Adds contents of register B to accumulator and result stores in accumulator

A = A + B

= (10)<sub>H</sub> + (10)<sub>H</sub>

0 0 0 1 0 0 0 0

ADD 0 0 0 1 0 0 0 0

A = 0 0 1 0 0 0 0 0

= (20)<sub>H</sub>



**NOTES**

RLC  $\Rightarrow$  Rotate accumulator left without carry

acc 

0	0	1	0	0	0	0	0
---	---	---	---	---	---	---	---

 CY=0

RLC 

0	0	1	0	0	0	0	0
---	---	---	---	---	---	---	---

 A=(40)<sub>H</sub>

JNC BACK  $\Rightarrow$  JUMP TO Back if CY = 0

NOP

ADD B  $\Rightarrow$  A = A + B

$$= (40)_H + (10)_H$$

$$\begin{array}{r} 0100\ 0000 \\ \text{ADD } 0001\ 0000 \\ \hline A = 0101\ 0000 \end{array}$$

$$= (60)_H$$

0	1	0	1	0	0	0	0
---	---	---	---	---	---	---	---

 CY=0

RLC A 

1	0	1	0	0	0	0	0
---	---	---	---	---	---	---	---

 CY=0

$$A = (A0)_H$$

JNC BACK

NOP

ADDB  $\Rightarrow$  A = A + B

$$= (A0)_H + (10)_H$$

$$\begin{array}{r} 1010\ 0000 \\ \text{ADD } 0001\ 0000 \\ \hline A = 1011\ 0000 \end{array}$$

$$A = (B0)_H$$

1	0	1	1	0	0	0	0
---	---	---	---	---	---	---	---

 CY=0

RLC A 

0	1	1	0	0	0	0	0
---	---	---	---	---	---	---	---

 CY=1

CY = 1 So it goes to HLT.

therefore NOP will be executed 3 times.

Hence (C) is correct option.

**SOL 8.113**

In the circuit

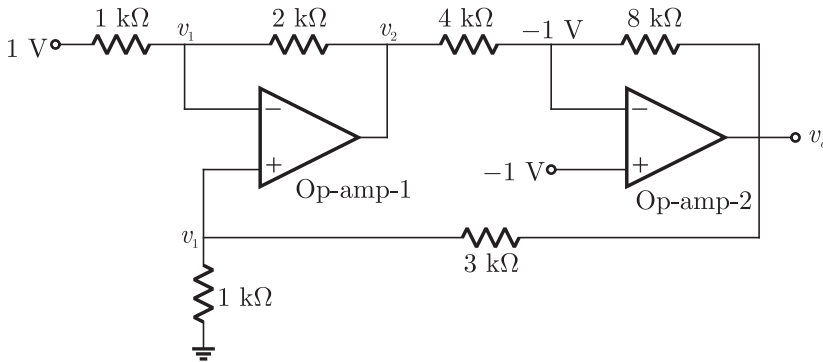

By writing node equation in the circuit at the negative terminal of op amp-1

$$\frac{v_1 - 1}{1} + \frac{v_1 - v_2}{2} = 0$$

$$3v_1 - v_2 = 2 \quad \dots(1)$$

Similarly, at the positive terminal of op amp-1

$$\frac{v_1 - v_o}{3} + \frac{v_1 - 0}{1} = 0$$

$$4v_1 - v_o = 0 \quad \dots(2)$$

At the negative terminals of op-amp-2

$$\left(\frac{-1 - v_2}{4}\right) + \left(\frac{-1 - v_o}{8}\right) = 0$$

$$-2 - 2v_2 - 1 - v_o = 0$$

$$v_o + 2v_2 = -3 \quad \dots(3)$$

From equation (1) and (2)

$$3\frac{v_o}{4} - 2v_2 = 1$$

From equation (3)

$$\frac{3}{4}v_o - 2(-3 - v_o) = 1$$

$$\frac{3}{4}v_o + v_o = -5$$

$$\frac{7}{4}v_o = -5$$

$$v_o = -\frac{20}{7} \text{ volt}$$

Hence (B) is correct option.

$$f_0 = \frac{1}{2\pi R_{eq} C_E}$$

Req → Equivalent resistance seen through capacitor  $C_E$

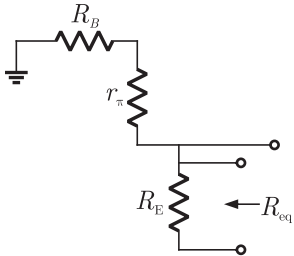

$$R_{eq} = R_E \parallel R_B + r_\pi = \frac{R_E(R_B + r_\pi)}{R_E + R_B + r_\pi}$$

So 
$$f_0 = \frac{1(R_E + R_B + r_\pi)}{2\pi R_E(R_B + r_\pi) C_E}$$

$$f_0 = 10 \text{ Hz (given)}$$

So, 
$$C_E = \frac{(0.1 + 25 + 5.2) \times 10^3}{2\pi \times 0.1 (25 + 5.2) \times 10^6} = 1.59 \text{ mF}$$

Hence (B) is correct option.

**SOL 8.116**

We can approximately analyze the circuit at low and high frequencies as following.

For low frequencies  $\omega \rightarrow 0 \Rightarrow \frac{1}{\omega_c} \rightarrow \infty$  (i.e. capacitor is open)

Equivalent circuit is

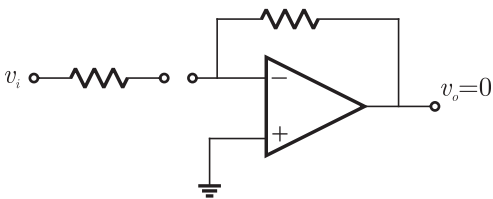

So, it does not pass the low frequencies.

For high frequencies  $\omega \rightarrow \infty \Rightarrow \frac{1}{\omega_c} \rightarrow 0$  (i.e. capacitor is short)

Equivalent circuit is

**NOTES**

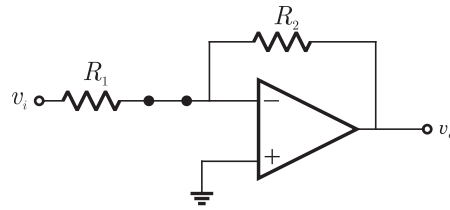

$$v_o = -\frac{R_2}{R_1} v_i$$

So it does pass the high frequencies. This is a high pass filter.  
Hence (D) is correct option.

**SOL 8.117**

At high frequency  $\omega \rightarrow \infty \Rightarrow \frac{1}{\omega_c} \rightarrow 0$ , capacitor behaves as short circuit  
and gain of the filter is given as

$$|A_v| = \left| -\frac{R_2}{R_1} \right| = 10$$

$$R_2 = 10 R_1$$

Input resistance of the circuit  $R_{in} = R_1 = 100 \text{ k}\Omega$

So,  $R_2 = 10 \times 100 \text{ k}\Omega = 1 \text{ M}\Omega$

Transfer function of the circuit

$$\frac{V_o(j\omega)}{V_i(j\omega)} = \frac{-j\omega R_2 C}{1 + j\omega R_1 C}$$

High frequency gain  $|A_{v\infty}| = 10$

At cutoff frequency gain is

$$|A_v| = \frac{10}{\sqrt{2}} = \left| \frac{-j\omega_c R_2 C}{1 + j\omega_c R_1 C} \right|$$

$$\frac{10}{\sqrt{2}} = \frac{\omega_c R_2 C}{\sqrt{1 + \omega_c^2 R_1^2 C^2}}$$

$$100 + 100\omega_c^2 R_1^2 C^2 = 2\omega_c^2 R_2^2 C^2$$

$$100 + 100 \times \omega_c^2 \times 10^{10} \times C^2 = 2 \times \omega_c^2 \times 10^{12} \times C^2$$

$$100 = \omega_c^2 C^2 \times 10^{12}$$

$$C^2 = \frac{100}{\omega_c^2 \times 10^{12}}$$

$$C = \frac{1}{2\pi f_c \times 10^4} = \frac{1}{2 \times 3.14 \times 10^3 \times 10^4}$$

$$= 15.92 \text{ nF}$$

\*\*\*\*\*

**NOTES**

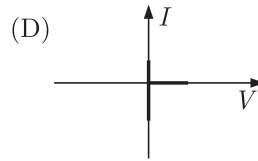
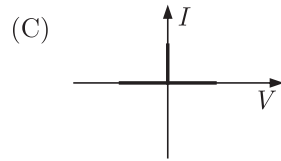
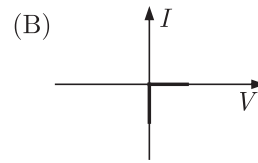
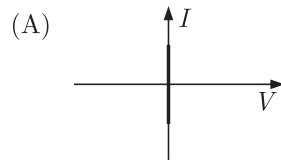

**MCQ 9.3**

The fully controlled thyristor converter in the figure is fed from a single-phase source. When the firing angle is  $0^\circ$ , the dc output voltage of the converter is 300 V. What will be the output voltage for a firing angle of  $60^\circ$ , assuming continuous conduction

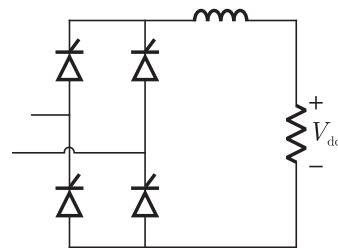

- (A) 150 V  
(C) 300 V

- (B) 210 V  
(D)  $100\pi$  V

**YEAR 2009**

**ONE MARK**

**MCQ 9.4**

An SCR is considered to be a semi-controlled device because

- (A) It can be turned OFF but not ON with a gate pulse.  
(B) It conducts only during one half-cycle of an alternating current wave.  
(C) It can be turned ON but not OFF with a gate pulse.  
(D) It can be turned ON only during one half-cycle of an alternating voltage wave.

**MCQ 9.5**

The circuit shows an ideal diode connected to a pure inductor and is connected to a purely sinusoidal 50 Hz voltage source. Under ideal conditions the current waveform through the inductor will look like.

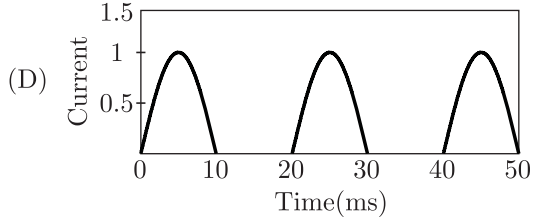
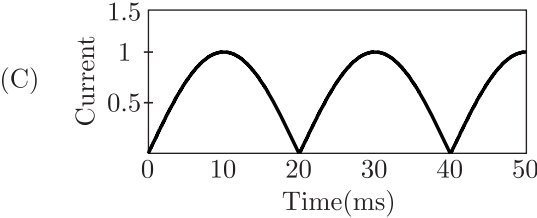
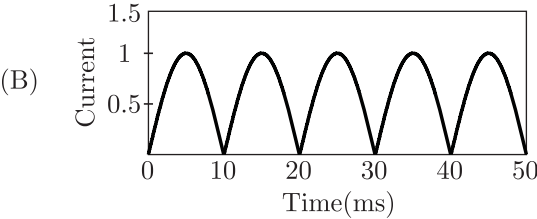
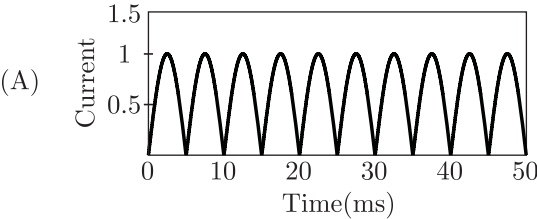
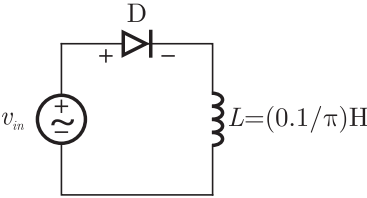

**MCQ 9.8**

Match the switch arrangements on the top row to the steady-state  $V-I$  characteristics on the lower row. The steady state operating points are shown by large black dots.

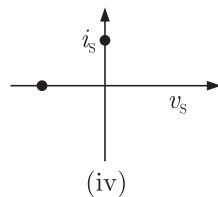
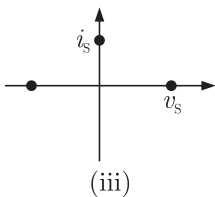
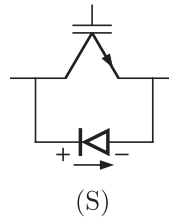
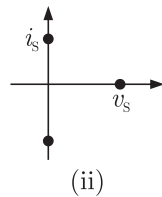
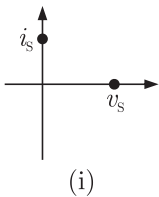
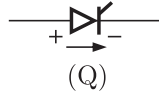
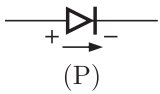

(A) P-I, Q-II, R-III, S-IV

(B) P-II, Q-IV, R-I, S-III

(C) P-IV, Q-III, R-I, S-II

(D) P-IV, Q-III, R-II, S-I

**YEAR 2008**

**ONE MARK**

**MCQ 9.9**

In the single phase voltage controller circuit shown in the figure, for what range of triggering angle ( $\alpha$ ), the input voltage ( $V_0$ ) is not controllable ?

**NOTES**

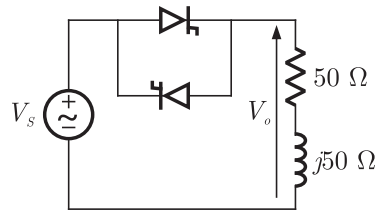

- (A)  $0^\circ < \alpha < 45^\circ$                       (B)  $45^\circ < \alpha < 135^\circ$   
 (C)  $90^\circ < \alpha < 180^\circ$                       (D)  $135^\circ < \alpha < 180^\circ$

**MCQ 9.10**

A 3-phase voltage source inverter is operated in  $180^\circ$  conduction mode. Which one of the following statements is true ?

- (A) Both pole-voltage and line-voltage will have 3<sup>rd</sup> harmonic components  
 (B) Pole-voltage will have 3<sup>rd</sup> harmonic component but line-voltage will be free from 3<sup>rd</sup> harmonic  
 (C) Line-voltage will have 3<sup>rd</sup> harmonic component but pole-voltage will be free from 3<sup>rd</sup> harmonic  
 (D) Both pole-voltage and line-voltage will be free from 3<sup>rd</sup> harmonic components

**YEAR 2008**

**TWO MARKS**

**MCQ 9.11**

The truth table of monoshot shown in the figure is given in the table below :

X	Y	Q	$\overline{Q}$
0	↑	Π	U
↓	1	Π	U

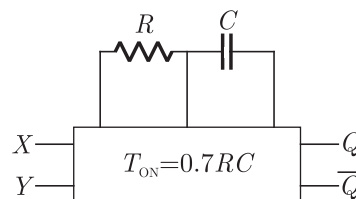

Two monoshots, one positive edge triggered and other negative edge triggered, are connected shown in the figure, The pulse widths of the two monoshot outputs  $Q_1$  and  $Q_2$  are  $T_{ON_1}$  and  $T_{ON_2}$  respectively.



**NOTES**

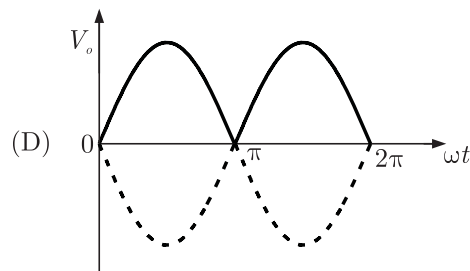
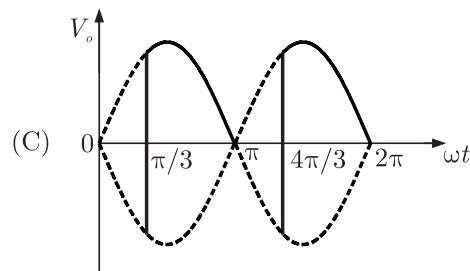
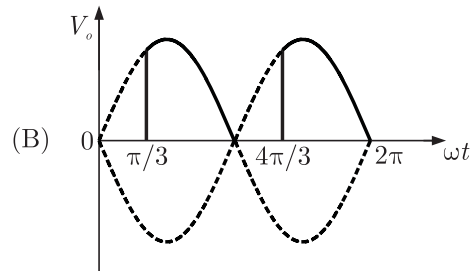
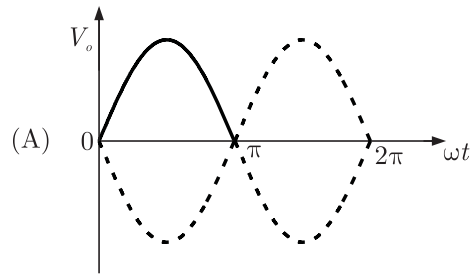

**MCQ 9.14**

A single phase source inverter is feeding a purely inductive load as shown in the figure

The inverter is operated at 50 Hz in 180° square wave mode. Assume that the load current does not have any dc component. The peak value of the inductor current  $i_0$  will be





common DC bus. The converter has to have a freewheeling diode.

- (A) because the converter inherently does not provide for free-wheeling
- (B) because the converter does not provide for free-wheeling for high values of triggering angles
- (C) or else the free-wheeling action of the converter will cause shorting of the AC supply
- (D) or else if a gate pulse to one of the SCRs is missed, it will subsequently cause a high load current in the other SCR.

**MCQ 9.21**

“Six MOSFETs connected in a bridge configuration (having no other power device) must be operated as a Voltage Source Inverter (VSI)”. This statement is

- (A) True, because being majority carrier devices MOSFETs are voltage driven.
- (B) True, because MOSFETs have inherently anti-parallel diodes
- (C) False, because it can be operated both as Current Source Inverter (CSI) or a VSI
- (D) False, because MOSFETs can be operated as excellent constant current sources in the saturation region.

**YEAR 2007**

**TWO MARKS**

**MCQ 9.22**

A single-phase voltage source inverter is controlled in a single pulse-width modulated mode with a pulse width of  $150^\circ$  in each half cycle. Total harmonic distortion is defined as

$$\text{THD} = \frac{\sqrt{V_{rms}^2 - V_1^2}}{V_1} \times 100$$

where  $V_1$  is the rms value of the fundamental component of the output voltage. The THD of output ac voltage waveform is

- (A) 65.65%
- (B) 48.42%
- (C) 31.83%
- (D) 30.49%

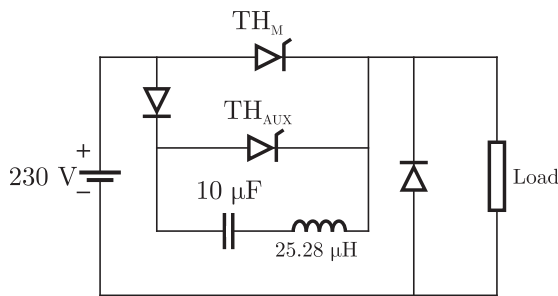

- (A)  $0 \mu s < t \leq 25 \mu s$                       (B)  $25 \mu s < t \leq 50 \mu s$   
 (C)  $50 \mu s < t \leq 75 \mu s$                       (D)  $75 \mu s < t \leq 100 \mu s$

**Common Data for Question 27 and 28.**

A 1:1 Pulse Transformer (PT) is used to trigger the SCR in the adjacent figure. The SCR is rated at 1.5 kV, 250 A with  $I_L = 250 \text{ mA}$ ,  $I_H = 150 \text{ mA}$ , and  $I_{G\text{max}} = 150 \text{ mA}$ ,  $I_{G\text{min}} = 100 \text{ mA}$ . The SCR is connected to an inductive load, where  $L = 150 \text{ mH}$  in series with a small resistance and the supply voltage is 200 V dc. The forward drops of all transistors/diodes and gate-cathode junction during ON state are 1.0 V

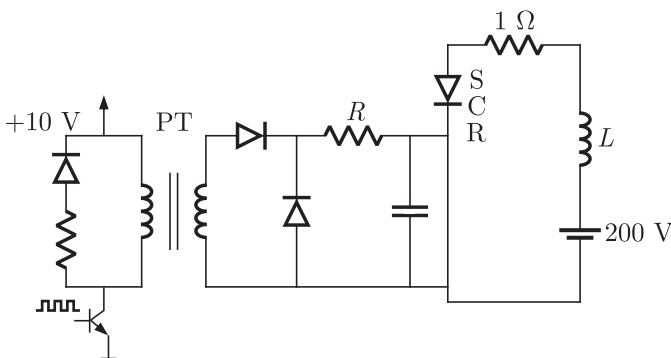

**MCQ 9.27**

The resistance  $R$  should be

- (A) 4.7 kΩ    (B) 470 kΩ  
 (C) 47 Ω    (D) 4.7 Ω

**NOTES**

**MCQ 9.28**

The minimum approximate volt-second rating of pulse transformer suitable for triggering the SCR should be : (volt-second rating is the maximum of product of the voltage and the width of the pulse that may applied)

- (A)  $2000 \mu\text{V-s}$  (B)  $200 \mu\text{V-s}$   
(C)  $20 \mu\text{V-s}$  (D)  $2 \mu\text{V-s}$

**YEAR 2006**

**ONE MARK**

**MCQ 9.29**

The speed of a 3-phase, 440 V, 50 Hz induction motor is to be controlled over a wide range from zero speed to 1.5 time the rated speed using a 3-phase voltage source inverter. It is desired to keep the flux in the machine constant in the constant torque region by controlling the terminal voltage as the frequency changes. The inverter output voltage vs frequency characteristic should be

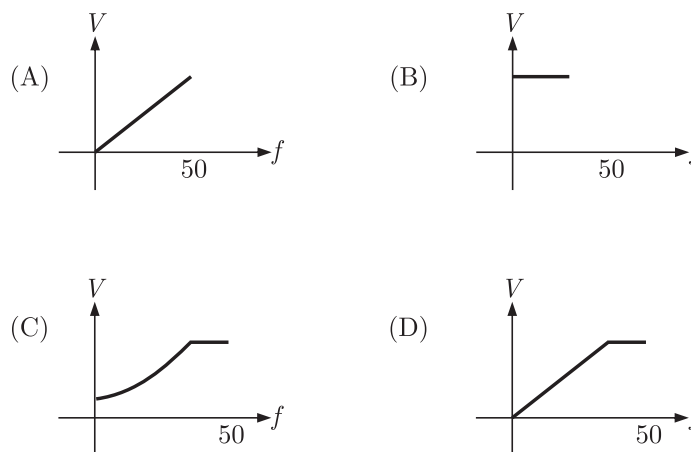

**MCQ 9.30**

A single-phase half wave uncontrolled converter circuit is shown in figure. A 2-winding transformer is used at the input for isolation. Assuming the load current to be constant and  $V = V_m \sin \omega t$ , the current waveform through diode  $D_2$  will be

**NOTES**

load inductance. The input displacement factor (IDF) and the input power factor (IPF) of the converter will be

- (A)  $IDF = 0.867; IPF = 0.828$       (B)  $IDF = 0.867; IPF = 0.552$   
 (C)  $IDF = 0.5; IPF = 0.478$       (D)  $IDF = 0.5; IPF = 0.318$

**MCQ 9.33**

A voltage commutation circuit is shown in figure. If the turn-off time of the SCR is  $50 \mu\text{sec}$  and a safety margin of 2 is considered, then what will be the approximate minimum value of capacitor required for proper commutation ?

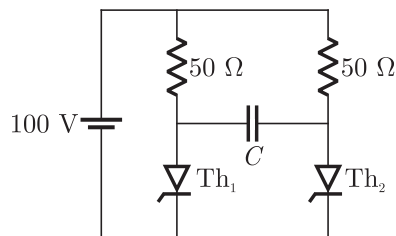

- (A)  $2.88 \mu\text{F}$       (B)  $1.44 \mu\text{F}$   
 (C)  $0.91 \mu\text{F}$       (D)  $0.72 \mu\text{F}$

**MCQ 9.34**

A solar cell of  $350 \text{ V}$  is feeding power to an ac supply of  $440 \text{ V}$ ,  $50 \text{ Hz}$  through a 3-phase fully controlled bridge converter. A large inductance is connected in the dc circuit to maintain the dc current at  $20 \text{ A}$ . If the solar cell resistance is  $0.5 \Omega$ , then each thyristor will be reverse biased for a period of

- (A)  $125^\circ$       (B)  $120^\circ$   
 (C)  $60^\circ$       (D)  $55^\circ$

**MCQ 9.35**

A single-phase bridge converter is used to charge a battery of  $200 \text{ V}$  having an internal resistance of  $0.2 \Omega$  as shown in figure. The SCRs are triggered by a constant dc signal. If  $SCR_2$  gets open circuited, what will be the average charging current ?





YEAR 2005

TWO MARKS

NOTES

**MCQ 9.42**

The figure shows the voltage across a power semiconductor device and the current through the device during a switching transitions. If the transition a turn ON transition or a turn OFF transition ? What is the energy lost during the transition?

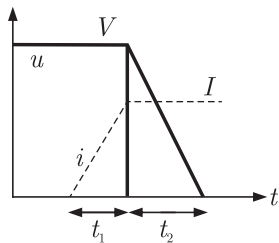

- (A) Turn ON,  $\frac{VI}{2}(t_1 + t_2)$       (B) Turn OFF,  $VI(t_1 + t_2)$   
 (C) Turn ON,  $VI(t_1 + t_2)$       (D) Turn OFF,  $\frac{VI}{2}(t_1 + t_2)$

**MCQ 9.43**

An electronics switch S is required to block voltage of either polarity during its OFF state as shown in the figure (a). This switch is required to conduct in only one direction its ON state as shown in the figure (b)

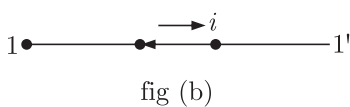
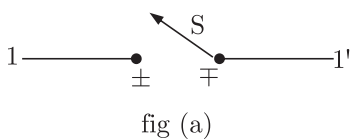

Which of the following are valid realizations of the switch S?

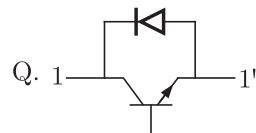

**NOTES**

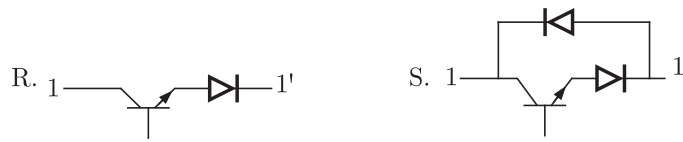

- (A) Only P  
(B) P and Q  
(C) P and R  
(D) R and S

**MCQ 9.44**

The given figure shows a step-down chopper switched at 1 kHz with a duty ratio  $D = 0.5$ . The peak-peak ripple in the load current is close to

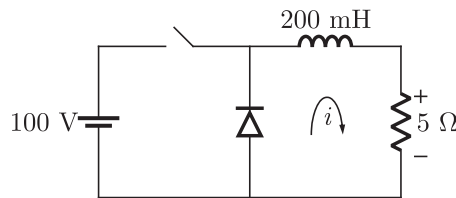

- (A) 10 A  
(B) 0.5 A  
(C) 0.125 A  
(D) 0.25 A

**MCQ 9.45**

An electric motor, developing a starting torque of 15 Nm, starts with a load torque of 7 Nm on its shaft. If the acceleration at start is  $2 \text{ rad/sec}^2$ , the moment of inertia of the system must be (neglecting viscous and coulomb friction)

- (A)  $0.25 \text{ kg-m}^2$   
(B)  $0.25 \text{ Nm}^2$   
(C)  $4 \text{ kg-m}^2$   
(D)  $4 \text{ Nm}^2$

**MCQ 9.46**

Consider a phase-controlled converter shown in the figure. The thyristor is fired at an angle  $\alpha$  in every positive half cycle of the input voltage. If the peak value of the instantaneous output voltage equals 230 V, the firing angle  $\alpha$  is close to

**NOTES**

(A)  $100\sqrt{2}$  V

(B) 100 V

(C)  $50\sqrt{2}$  V

(D) 50 V

**MCQ 9.49**

The triggering circuit of a thyristor is shown in figure. The thyristor requires a gate current of 10 mA, for guaranteed turn-on. The value of  $R$  required for the thyristor to turn on reliably under all conditions of  $V_b$  variation is

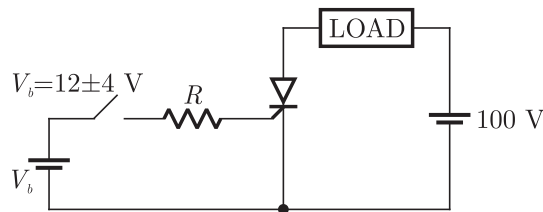

(A) 10000  $\Omega$

(B) 1600  $\Omega$

(C) 1200  $\Omega$

(D) 800  $\Omega$

**MCQ 9.50**

The circuit in figure shows a 3-phase half-wave rectifier. The source is a symmetrical, 3-phase four-wire system. The line-to-line voltage of the source is 100 V. The supply frequency is 400 Hz. The ripple frequency at the output is

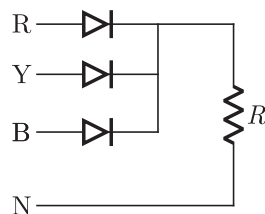

(A) 400 Hz

(B) 800 Hz

(C) 1200 Hz

(D) 2400 Hz

**YEAR 2004**

**TWO MARKS**

**MCQ 9.51**

A MOSFET rated for 15 A, carries a periodic current as shown in figure. The ON state resistance of the MOSFET is 0.15  $\Omega$ . The



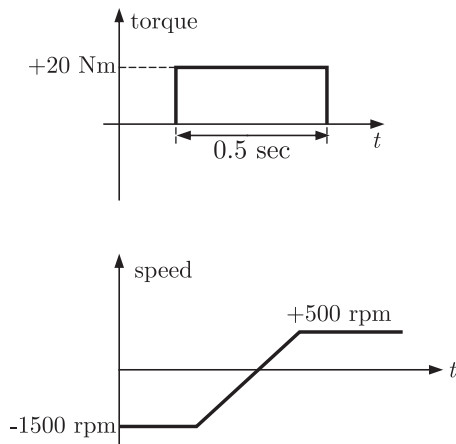

- (A)  $0.048 \text{ kg-m}^2$                       (B)  $0.064 \text{ kg-m}^2$   
 (C)  $0.096 \text{ kg-m}^2$                       (D)  $0.128 \text{ kg-m}^2$

**YEAR 2003** **ONE MARK**

**MCQ 9.57**

Figure shows a thyristor with the standard terminations of anode (A), cathode (K), gate (G) and the different junctions named J1, J2 and J3. When the thyristor is turned on and conducting

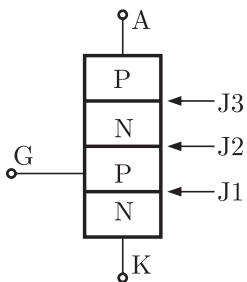

- (A) J1 and J2 are forward biased and J3 is reverse biased  
 (B) J1 and J3 are forward biased and J2 is reverse biased  
 (C) J1 is forward biased and J2 and J3 are reverse biased  
 (D) J1, J2 and J3 are all forward biased

**NOTES**

**MCQ 9.58**

Figure shows a MOSFET with an integral body diode. It is employed as a power switching device in the ON and OFF states through appropriate control. The ON and OFF states of the switch are given on the  $V_{DS} - I_S$  plane by

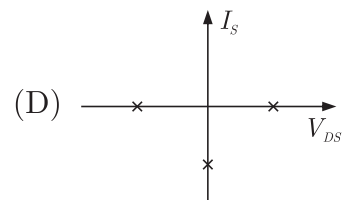
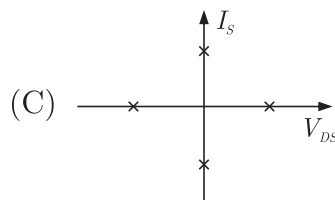
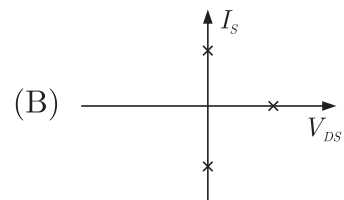
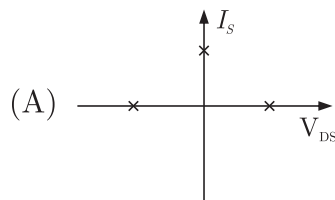
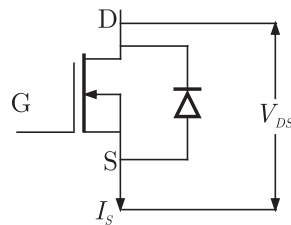

**MCQ 9.59**

The speed/torque regimes in a dc motor and the control methods suitable for the same are given respectively in List-II and List-I

**List-I**

- P. Field Control
- Q. Armature Control

**List-II**

1. Below base speed
2. Above base speed
3. Above base torque
4. Below base torque

**Codes:**

- (A) P-1, Q-3
- (B) P-2, Q-1
- (C) P-2, Q-3
- (D) P-1, Q-4

**NOTES**

**MCQ 9.62**

A chopper is employed to charge a battery as shown in figure. The charging current is 5 A. The duty ratio is 0.2. The chopper output voltage is also shown in the figure. The peak to peak ripple current in the charging current is

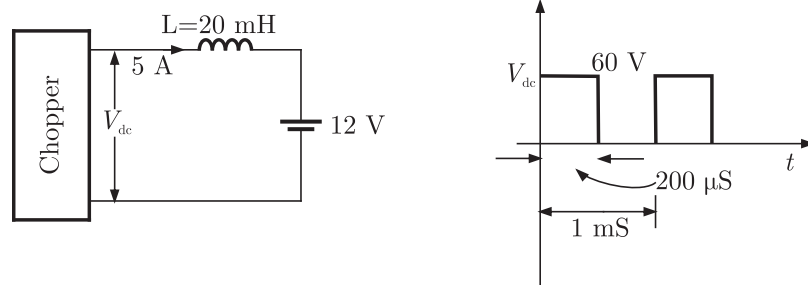

- (A) 0.48 A
- (B) 1.2 A
- (C) 2.4 A
- (D) 1 A

**MCQ 9.63**

An inverter has a periodic output voltage with the output wave form as shown in figure

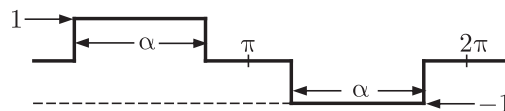

When the conduction angle  $\alpha = 120^\circ$ , the rms fundamental component of the output voltage is

- (A) 0.78 V
- (B) 1.10 V
- (C) 0.90 V
- (D) 1.27 V

**MCQ 9.64**

With reference to the output wave form given in above figure, the output of the converter will be free from 5<sup>th</sup> harmonic when

- (A)  $\alpha = 72^\circ$
- (B)  $\alpha = 36^\circ$
- (C)  $\alpha = 150^\circ$
- (D)  $\alpha = 120^\circ$

**MCQ 9.65**

An ac induction motor is used for a speed control application. It is driven from an inverter with a constant  $V/f$  control. The motor name-plate details are as follows (no. of poles = 2)

$V: 415 \text{ V}$   $V_{Ph}: 3 \text{ V}$   $f: 50 \text{ Hz}$   $N: 2850 \text{ rpm}$

The motor runs with the inverter output frequency set at 40 Hz, and with half the rated slip. The running speed of the motor is

- (A) 2400 rpm (B) 2280 rpm  
(C) 2340 rpm (D) 2790 rpm

**YEAR 2002**

**ONE MARK**

**MCQ 9.66**

A six pulse thyristor rectifier bridge is connected to a balanced 50 Hz three phase ac source. Assuming that the dc output current of the rectifier is constant, the lowest frequency harmonic component in the ac source line current is

- (A) 100 Hz (B) 150 Hz  
(C) 250 Hz (D) 300 Hz

**MCQ 9.67**

A step-down chopper is operated in the continuous conduction mode is steady state with a constant duty ratio  $D$ . If  $V_0$  is the magnitude of the dc output voltage and if  $V_s$  is the magnitude of the dc input voltage, the ratio  $V_0/V_s$  is given by

- (A)  $D$  (B)  $1 - D$   
(C)  $\frac{1}{1 - D}$  (D)  $\frac{D}{1 - D}$

**YEAR 2002**

**TWO MARKS**

**MCQ 9.68**

In the chopper circuit shown in figure, the input dc voltage has a constant value  $V_s$ . The output voltage  $V_0$  is assumed ripple-free. The switch S is operated with a switching time period  $T$  and a duty ratio  $D$ . What is the value of  $D$  at the boundary of continuous and discontinuous conduction of the inductor current  $i_L$ ?



(A)  $\frac{3200}{\pi}$  W

(B)  $\frac{400}{\pi}$  W

(C) 400 W

(D) 800 W

**MCQ 9.71\***

The semiconductor switch  $S$  in the circuit of figure is operated at a frequency of 20 kHz and a duty ratio  $D = 0.5$ . The circuit operates in the steady state. Calculate the power transferred from the dc voltage source  $V_2$ .

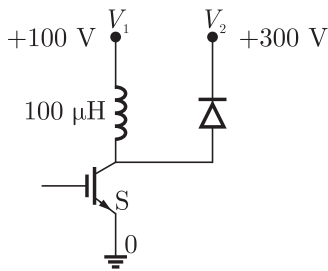

**YEAR 2001**

**ONE MARK**

**MCQ 9.72**

The main reason for connecting a pulse transformer at the output stage of thyristor triggering circuit is to

- (A) amplify the power of the triggering pulse
- (B) provide electrical isolation
- (C) reduce the turn on time of thyristor
- (D) avoid spurious triggering of the thyristor due to noise

**MCQ 9.73**

AC-to-DC circulating current dual converters are operated with the following relationship between their triggering angles ( $\alpha_1$  and  $\alpha_2$ )

- (A)  $\alpha_1 + \alpha_2 = 180^\circ$
- (B)  $\alpha_1 + \alpha_2 = 360^\circ$
- (C)  $\alpha_1 - \alpha_2 = 180^\circ$
- (D)  $\alpha_1 + \alpha_2 = 90^\circ$

**MCQ 9.74**

A half-wave thyristor converter supplies a purely inductive load as shown in figure. If the triggering angle of the thyristor is  $120^\circ$ , the extinction angle will be

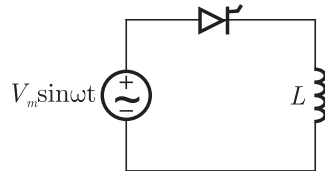

- (A)  $240^\circ$  (B)  $180^\circ$   
(C)  $200^\circ$  (D)  $120^\circ$

**MCQ 9.75**

A single-phase full bridge voltage source inverter feeds a purely inductive load as shown in figure, where  $T_1, T_2, T_3, T_4$  are power transistors and  $D_1, D_2, D_3, D_4$  are feedback diodes. The inverter is operated in square-wave mode with a frequency of 50 Hz. If the average load current is zero, what is the time duration of conduction of each feedback diode in a cycle?

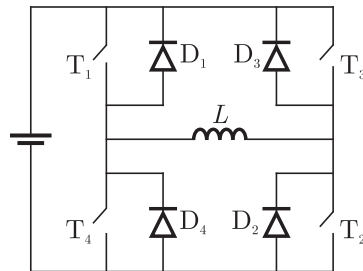

- (A) 5 msec (B) 10 msec  
(C) 20 msec (D) 2.5 msec

**MCQ 9.76\***

A voltage commutated thyristor chopper circuit is shown in figure. The chopper is operated at 500 Hz with 50% duty ratio. The load takes a constant current of 20 A.

- (a) Evaluate the circuit turn off time for the main thyristor  $Th_1$ .

## SOLUTION

### SOL 9.1

The figure shows a step down chopper circuit.

$$\therefore V_{\text{out}} = DV_{\text{in}}$$

where,  $D$  = Duty cycle and  $D < 1$

Hence (A) is correct option.

### SOL 9.2

Given figure as

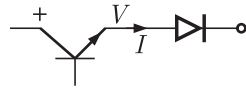

The  $I$ - $V$  characteristic are as

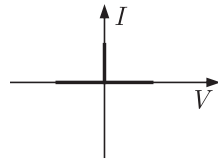

Since diode connected in series so  $I$  can never be negative.

When current flows voltage across switch is zero and when current is zero then there may be any voltage across switch.

Hence (C) is correct option.

### SOL 9.3

Given fully-controlled thyristor converter, when firing angle  $\alpha = 0$ ,  
dc output voltage  $V_{dc_0} = 300$  V

$$\text{If } \alpha = 60^\circ, \text{ then } V_{dc} = ?$$

we know for fully-controlled converter

$$V_{dc_0} = \frac{2\sqrt{2}}{\pi} V_{dc_1} \cos \alpha$$

$$\therefore \alpha = 0, V_{dc_0} = 300 \text{ V}$$

$$300 = \frac{2\sqrt{2}}{\pi} V_{dc_1} \cos 0^\circ$$

$$V_{dc_1} = \frac{300\pi}{2\sqrt{2}}$$

at  $\alpha = 60^\circ$ ,  $V_{dc_2} = ?$

$$\begin{aligned} V_{dc_2} &= \frac{2\sqrt{2}}{\pi} \times \frac{300\pi}{2\sqrt{2}} \cos 60^\circ \\ &= 300 \times \frac{1}{2} = 150 \text{ V} \end{aligned}$$

Hence (A) is correct option.

**SOL 9.4**

SCR has the property that it can be turned ON but not OFF with a gate pulse, So SCR is being considered to be a semi-controlled device.

Hence (C) is correct option.

**SOL 9.5**

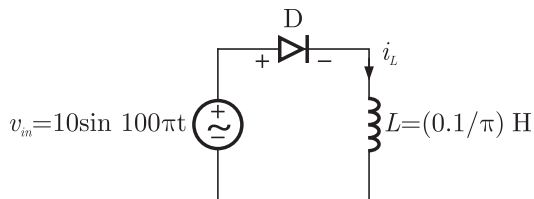

Current wave form for  $i_L$

$$v_L = \frac{L di_L}{dt}$$

$$i_L = \frac{1}{2} \int v_L dt$$

for  $0 < \omega t < \pi$ ,

$$v_L = v_{in} = 10 \sin \omega t = \frac{di_L}{dt}$$

$$i_L = \frac{1}{2} \int v_L dt = -\cos 100\pi t + C$$

at  $100\pi t = \pi/2$ ,

$$i_L = 0, C = 0$$

$$i_L = -100 \cos \pi t$$

$$i_{L(\text{peak})} = 1 \text{ Amp} \quad \text{for } \pi < \omega t \quad v_L = v_{in} = 0$$

$$10 = C_1 \times \frac{50}{10^{-6}}$$

$$C_1 = \frac{50}{10} \times 10^{-6} = 0.2 \mu\text{F}$$

Hence (A) is correct option.

**SOL 9.8**

Characteristics are as

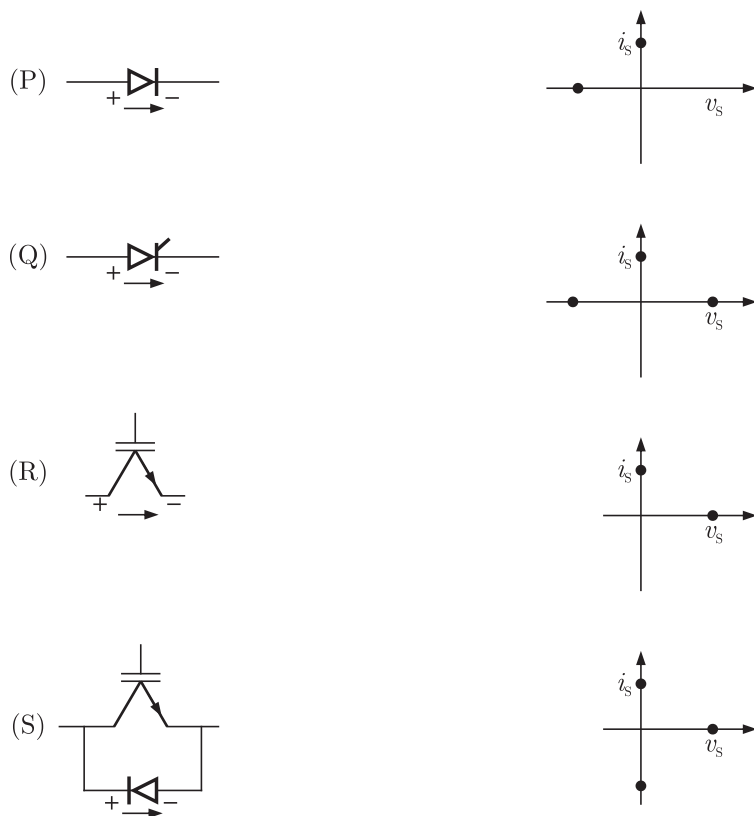

Hence (C) is correct option.

**SOL 9.9**

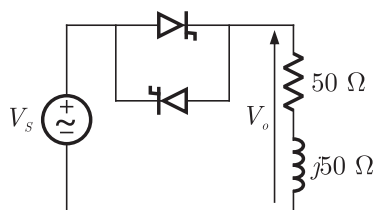

**NOTES**

$$R + jXL = 50 + 50j$$

$$\therefore \tan \phi = \frac{\omega L}{R} = \frac{50}{50} = 1$$

$$\phi = 45^\circ$$

so, firing angle ' $\alpha$ ' must be higher than  $45^\circ$ , Thus for  $0 < \alpha < 45^\circ$ ,  $V_0$  is uncontrollable.

Hence (A) is correct option.

**SOL 9.10**

A 3- $\phi$  voltage source inverter is operated in  $180^\circ$  mode in that case third harmonics are absent in pole voltage and line voltage due to the factor  $\cos(n\pi/6)$ . so both are free from 3<sup>rd</sup> harmonic components.

Hence (D) is correct option.

**SOL 9.11**

In this case

$$f = \frac{1}{T_{ON1} + T_{ON2}}$$

and, 
$$D = \frac{T_{ON2}}{T_{ON1} + T_{ON2}}$$

Hence (B) is correct option.

**SOL 9.12**

Given  $\alpha = 30^\circ$ , in a 1- $\phi$  fully bridge converter we know that,

$$\text{Power factor} = \text{Distortion factor} \times \cos \alpha$$

$$\text{D.f. (Distortion factor)} = I_{s(\text{fundamental})}/I_s = 0.9$$

$$\begin{aligned} \text{power factor} &= 0.9 \times \cos 30^\circ \\ &= 0.78 \end{aligned}$$

Hence (B) is correct option.

**NOTES**

**SOL 9.15**

Here for continuous conduction mode, by Kirchoff's voltage law, average load current

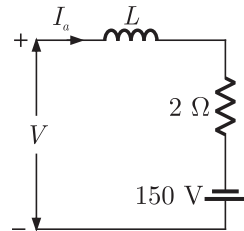

$$V - 2I_a + 150 = 0$$

$$I_a = \frac{V + 150}{2}$$

$\therefore I_1 = 10$  A, So

$$V = -130$$
 V

$$\frac{2V_m \cos \alpha}{\pi} = -130$$

$$\frac{2 \times \sqrt{2} \times 230}{\pi} \cos \alpha = -130^\circ$$

$$\alpha = 129^\circ$$

Hence (C) is correct option.

**SOL 9.16**

$$\text{Total rms current } I_a = \sqrt{\frac{2}{3}} \times 10 = 8.16 \text{ A}$$

$$\text{Fundamental current } I_{a1} = 0.78 \times 10 = 7.8 \text{ A}$$

$$\text{THD} = \sqrt{\frac{1}{\text{DF}^2} - 1}$$

where

$$\text{DF} = \frac{I_{a1}}{I_a} = \frac{0.78 \times 10}{0.816 \times 10} = 0.955$$

$$\therefore \text{THD} = \sqrt{\left(\frac{1}{0.955}\right)^2 - 1} = 31\%$$

Hence (B) is correct option.

**SOL 9.17**

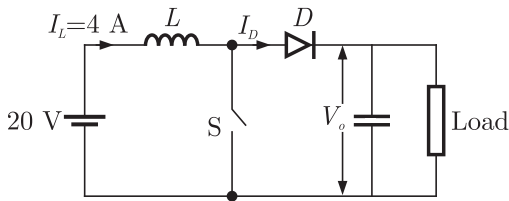

In the given diagram

when switch S is open  $I_0 = I_L = 4 \text{ A}$ ,  $V_s = 20 \text{ V}$

when switch S is closed  $I_D = 0$ ,  $V_o = 0 \text{ V}$

Duty cycle = 0.5 so average voltage is  $\frac{V_s}{1 - \delta}$

$$\text{Average current} = \frac{0 + 4}{2} = 2 \text{ amp}$$

$$\text{Average voltage} = \frac{20}{1 - 0.5} = 40 \text{ V}$$

Hence (C) is correct option.

**SOL 9.18**

Firing angle  $\alpha = 25^\circ$

Overlap angle  $\mu = 10^\circ$

$$\text{so, } I_0 = \frac{V_m}{\omega L_s} [\cos \alpha - \cos(\alpha + \mu)]$$

$$\therefore 20 = \frac{230\sqrt{2}}{2\pi \times 50L_s} [\cos 25^\circ - \cos(25^\circ + 10^\circ)]$$

$$\therefore L_s = 0.0045 \text{ H}$$

$$\begin{aligned} V_0 &= \frac{2V_m \cos \alpha}{\pi} - \frac{\omega L_s I_0}{\pi} \\ &= \frac{2 \times 230\sqrt{2} \cos 25^\circ}{3.14} - \frac{2 \times 3.14 \times 50 \times 4.5 \times 10^{-3} \times 20}{3.14} \\ &= 187.73 - 9 = 178.74^\circ \end{aligned}$$

$$\begin{aligned} \text{Displacement factor} &= \frac{V_0 I_0}{V_s I_s} \\ &= \frac{178.25 \times 20}{230 \times 20} = 0.78 \end{aligned}$$

Hence (A) is correct option.



**SOL 9.23**

When losses are neglected,

$$\frac{3 \times \sqrt{2} \times 440}{\pi} \cos \alpha = K_m \times \frac{750 \times 2\pi}{60}$$

Here back emf  $\varepsilon$  with  $\phi$  is constant

$$\begin{aligned} \varepsilon &= V_0 = K_m \omega_m \\ 440 &= K_m \times \frac{1500 \times 2\pi}{60} \end{aligned}$$

$$K_m = 2.8$$

$$\cos \alpha = 0.37$$

at this firing angle

$$V_t = \frac{3\sqrt{2} \times 440}{\pi} \times (0.37) = 219.85 \text{ V}$$

$$I_a = \frac{1500}{440} = 34.090$$

$$I_{sr} = I_a \sqrt{2/3} = 27.83$$

$$\text{p.f.} = \frac{V_t I_s}{\sqrt{3} V_s I_{sr}} = 0.354$$

Hence (A) is correct option.

**SOL 9.24**

$$V_s = \frac{230}{4} = 57.5$$

Here charging current =  $I$

$$V_m \sin \theta = 12$$

$$\theta_1 = 8.486 = 0.148 \text{ radian}$$

$$V_m = 81.317 \text{ V}$$

$$\varepsilon = 12 \text{ V}$$

There is no power consumption in battery due to ac current, so average value of charging current.

$$\begin{aligned} I_{av(\text{charging})} &= \frac{1}{2\pi \times 19.04} [2 V_m \cos \theta_1 - \varepsilon (\pi - 2\theta_1)] \\ &= \frac{1}{2\pi \times 19.04} [2 \times V_m \times \cos \theta_1 - 12 (\pi - 2\theta_1)] \\ &= 1.059 \text{ A} \end{aligned}$$

Hence (D) is correct option.

**NOTES**

**SOL 9.25**

Conduction angle for diode is  $270^\circ$  as shown in fig.

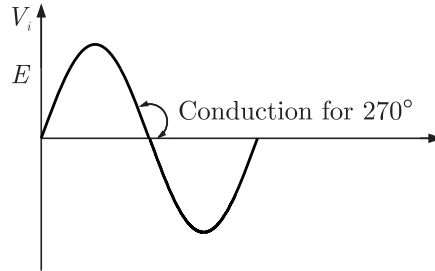

Hence (C) is correct option.

**SOL 9.26**

**SOL 9.27**

Here,  $V_m$  = maximum pulse voltage that can be applied  
so  $= 10 - 1 - 1 - 1 = 7$  V

Here 1 V drop is in primary transistor side, so that we get 9V pulse on the secondary side. Again there are 1 V drop in diode and in gate cathode junction each.

$$I_{g \max} = 150 \text{ mA}$$

So 
$$R = \frac{V_m}{I_{g \max}} = \frac{7}{150 \text{ mA}} = 46.67 \Omega$$

Hence (C) is correct option.

**SOL 9.28**

We know that the pulse width required is equal to the time taken by  $i_a$  to rise upto  $i_L$

so,

$$V_s = L \frac{di}{dt} + R_i (V_T \approx 0)$$

$$i_a = \frac{200}{1} [1 - e^{-t/0.15}]$$

Here also  $t = T$ ,

$$i_a = i_L = 0.25$$

$$0.25 = 200 [1 - e^{-T/0.15}]$$

$$T = 1.876 \times 10^{-4} = 187.6 \mu\text{s}$$

$$\text{Width of pulse} = 187.6 \mu\text{s}$$

**NOTES**

$$\text{so, } \left( \frac{V_{03}}{V_{01\max}} \right) = \frac{\frac{4V_s}{3\pi} \times \sin(3 \times 72^\circ)}{\frac{4V_s}{\pi} \sin 72^\circ} = 19.61\%$$

Hence (B) is correct option.

**SOL 9.32**

Given that

400 V, 50 Hz AC source,  $\alpha = 60^\circ$ ,  $I_L = 10$  A

so,

Input displacement factor =  $\cos \alpha = 0.5$

and, input power factor = D.F.  $\times \cos \alpha$

$$\begin{aligned} \text{distortion factor} &= \frac{I_{s(\text{fundamental})}}{I_s} \\ &= \frac{4 \times 10}{\pi \times \sqrt{2}} \sin 60^\circ \\ &= \frac{10 \times \sqrt{2/3}}{10 \times \sqrt{2/3}} \\ &= 0.955 \end{aligned}$$

$$\begin{aligned} \text{so, input power factor} &= 0.955 \times 0.5 \\ &= 0.478 \end{aligned}$$

Hence (C) is correct option.

**SOL 9.33**

We know that

$$T = RC \ln 2$$

$$\begin{aligned} \text{So } C &= \frac{T}{R \times 0.693} \\ &= \frac{100}{50 \times 0.693} \\ &= 2.88 \mu\text{F} \end{aligned}$$

Hence (A) is correct option.

**SOL 9.34**

Let we have

$$R_{\text{solar}} = 0.5 \Omega, I_0 = 20 \text{ A}$$

$$\text{so } V_s = 350 - 20 \times 0.5 = 340 \text{ V}$$

$$\therefore 340 = \frac{3 \times 440 \times \sqrt{2}}{\pi} \cos \alpha$$

$$\cos \alpha = 55^\circ$$

So each thyristor will reverse biased for  $180^\circ - 55^\circ = 125^\circ$ .

Hence (A) is correct option.

**SOL 9.35**

In this circuitry if SCR gets open circuited, than circuit behaves like a half wave rectifier.

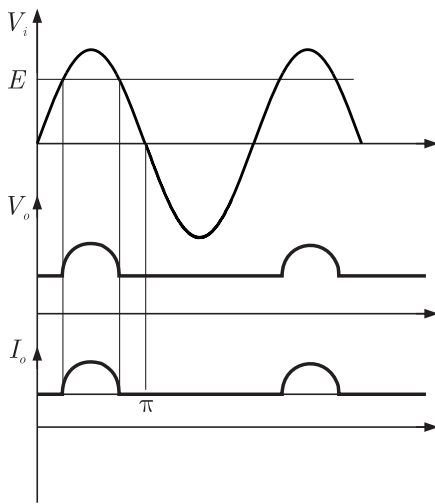

So

$I_{avg}$  = Average value of current

$$= \frac{1}{2\pi R} \int_{\theta_1}^{\pi - \theta_1} (V_m \sin \omega t - E) d\theta$$

$$\therefore I_{0(avg)} = \frac{1}{2\pi R} [2 V_m \cos \theta - E(\pi - 2\theta_1)]$$

$$= \frac{1}{2\pi \times 2} [2 \times (230 \times \sqrt{2}) \cos \theta - 200(\pi - 2\theta_1)]$$

$$\theta_1 = \sin^{-1} \left( \frac{E}{V_m} \right)$$

$$= \sin^{-1} \left( \frac{200}{230 \times \sqrt{2}} \right) = 38^\circ = 0.66 \text{ Rad}$$

$$\therefore I_{0(avg)} = \frac{1}{2\pi \times 2} [2\sqrt{2} \times 230 \cos 38^\circ - 200(\pi - 2 \times 0.66)]$$

$$= 11.9 \text{ A}$$

Hence (C) is correct option.

**NOTES**

$$(\Delta I)_{\max} = \frac{V_s}{4fL} = \frac{100}{4 \times 10^3 \times 200 \times 10^{-3}}$$

$$= 0.125 \text{ A}$$

Hence (C) is correct option.

**SOL 9.45**

$$T_{\text{st}} = 15 \text{ Nm}$$

$$T_L = 7 \text{ Nm}$$

$$\alpha = 2 \text{ rad/sec}^2$$

$$T = I\alpha$$

so

$$T = T_{\text{st}} - T_L = 8 \text{ Nm}$$

$$I = \frac{8}{2} = 4 \text{ kgm}^2$$

Hence (C) is correct option.

**SOL 9.46**

We know that

$$V_{\text{rms}} = 230 \text{ V}$$

so,

$$V_m = 230 \times \sqrt{2} \text{ V}$$

If whether

$$\alpha < 90^\circ$$

Then

$$V_{\text{peak}} = V_m \sin \alpha = 230$$

$$230\sqrt{2} \sin \alpha = 230$$

$$\sin \alpha = \frac{1}{\sqrt{2}}$$

$$\text{angle } \alpha = 135^\circ$$

Hence (B) is correct option.

**SOL 9.47**

When we use BJT as a power control switch by biasing it in cut-off region or in the saturation region. In the on state both the base emitter and base-collector junction are forward biased.

Hence (D) is correct option.

**SOL 9.48**

Peak Inverse Voltage (PIV) across full wave rectifier is  $2V_m$

$$V_m = 50\sqrt{2} \text{ V}$$

so,  $\text{PIV} = 100\sqrt{2} \text{ V}$

Hence (A) is correct option.

**SOL 9.49**

$$V_b = 12 \pm 4 \text{ V}$$

$$V_{b\max} = 16 \text{ V}$$

$$V_{b\min} = 8 \text{ V}$$

$$\text{Required value of } R = \frac{V_b(\min)}{I_g} = \frac{8}{10 \times 10^{-3}} = 800 \Omega$$

Hence (D) is correct option.

**SOL 9.50**

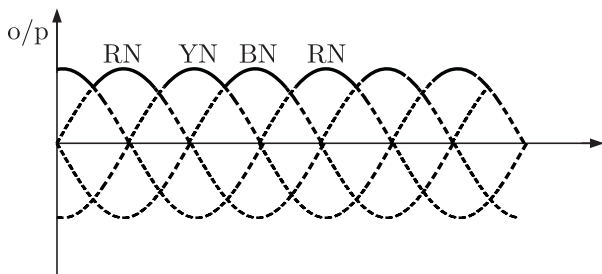

$$\text{Ripple frequency} = 3f = 3 \times 400 = 1200 \text{ Hz}$$

So from  $V_0$  ripple frequency = 1200 Hz

Hence (C) is correct option.

**SOL 9.51**

Given that

$$R = 0.15 \Omega$$

$$I = 15 \text{ A}$$

$$\begin{aligned} \text{So average power losses} &= \frac{1}{(2\pi/\omega)} \int_0^{\pi/\omega} I^2 R dt \\ &= \frac{\omega}{2\pi} \times 10^2 \times 0.15 \times \pi/\omega \\ &= 7.5 \text{ W} \end{aligned}$$

Hence (C) is correct option.

**SOL 9.52**

Output dc voltage across load is given as following

$$\begin{aligned} V_{dc} &= \sqrt{2} V \left[ \frac{1}{\alpha\pi} \left\{ (2\pi - \alpha) + \frac{\sin 2\alpha}{2} \right\} \right]^{\frac{1}{2}} \\ &= \sqrt{2} \times 230 \sqrt{2} \left[ \frac{1}{\frac{\pi}{4} \times \pi} \left\{ \left( 2\pi - \frac{\pi}{4} \right) + \left( \frac{\sin \pi/2}{2} \right) \right\} \right]^{\frac{1}{2}} \end{aligned}$$

**SOL 9.57**

When thyristor turned on at that time J2 junction will break. So J1, J2, J3 all are in forward bias.  
Hence (D) is correct option.

**SOL 9.58**

The ON-OFF state of switch is given on  $V_{DS} - I_S$  plane as following

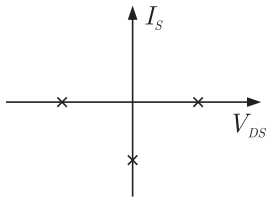

When  $V_{DS} = +ve$ , diode conducts and  $I_S = 0$   
 $V_{DS} = -ve$ , diode opens, but  $I_S = 0$ ,  $D \rightarrow -ve$  potential.  
Hence (D) is correct option.

**SOL 9.59**

P. Field control-Above base speed  
 Q. Armature control-below base torque  
 Hence (B) is correct option.

**SOL 9.60**

As we know in fully controlled rectifier.

$$V_{PP} = V_m - V_m \cos(\pi/6 + \alpha) \quad \because \alpha = 30^\circ$$

or  $V_{PP} = V_m [1 - \cos(\pi/6 + 30^\circ)]$

or  $\frac{V_{PP}}{V_m} = 0.5$

Hence (A) is correct option.

**SOL 9.61**

**SOL 9.62**

In the chopper during turn on of chopper  $V-t$  area across  $L$  is,

$$\begin{aligned} \int_0^{T_{on}} V_L dt &= \int_0^{T_{on}} L \left( \frac{di}{dt} \right) dt = \int_{i_{min}}^{i_{max}} L di \\ &= L(i_{max} - i_{min}) = L(\Delta I) \end{aligned}$$

**NOTES**

**SOL 9.68**

**SOL 9.69**

From figure

$$\begin{aligned}(V_{12})_{\text{rms}} &= \left[ \frac{1}{\pi} \int_0^{\phi} V_s^2 d\omega \right]^{1/2} \\ &= \frac{V_s}{\sqrt{\pi}} \times \sqrt{\phi} = V_s \sqrt{\frac{\phi}{\pi}}\end{aligned}$$

Hence (B) is correct option.

**SOL 9.70**

Given that,  $V = 200 \sin \omega t$   
 $f = 50 \text{ Hz}$

Power dispatched in the load resistor  $R = ?$

First we have to calculate output of rectifier.

$$\begin{aligned}(V_0)_{\text{rms}} &= \left[ \frac{1}{\pi} \int_0^{\pi} (200 \sin \omega t)^2 d\omega t \right]^{1/2} \\ &= \frac{200}{\sqrt{\pi}} \left[ \int_0^{\pi} \left( \frac{1 - \cos 2\omega t}{2} \right) d\omega t \right]^{1/2} \\ &= \frac{200}{\sqrt{\pi}} \left[ \frac{1}{2} \left( \omega t - \frac{\sin 2\omega t}{2} \right) \right]_0^{\pi}^{1/2} \\ &= \frac{200}{\sqrt{\pi}} \left[ \frac{1}{2} \times \pi \right]^{1/2} = \frac{200}{\sqrt{2}}\end{aligned}$$

Power dissipated to resistor

$$\begin{aligned}P_R &= \frac{(V_0)_{\text{rms}}^2}{R} \\ &= \left( \frac{200/\sqrt{2}}{50} \right)^2 = 400 \text{ W}\end{aligned}$$

Hence (C) is correct option.

**SOL 9.71\***

Given  $f = 20 \text{ kHz}$   
 $D = 0.5$

Power transferred from source  $V_1$  to  $V_2 = ?$

$$\text{Time period } t = \frac{1}{f} = \frac{1}{20 \times 10^3} = 50 \mu\text{sec}$$



$$D = 0.5$$

$$t_{\text{ON}} = 25 \mu\text{sec}, t_{\text{off}} = 25 \mu\text{sec}$$

at  $t_{\text{ON}}$ , energy will be stored in inductor circuit

$$v = L \frac{di}{dt}$$

$$100 = 100 \times 10^{-6} \frac{di}{dt}$$

$$\frac{di}{dt} = 10^6$$

$$i = 10^6 t + i(0) \quad \because i(0) = 0$$

$$i = 10^6 t \quad \dots(1)$$

$$E = \frac{1}{2} L i^2$$

$$E = \frac{1}{2} \times 100 \times 10^{-6} \times 10^{12} \times 25 \times 25 \times 10^{-12}$$

$$E = 3.1250 \times 10^{-2} \text{ J}$$

Now power transferred during  $t_{\text{off}}$

$$P_t = \frac{3.1250 \times 10^{-2}}{25 \times 10^{-6}} = 12.5 \times 10^2 \text{ W}$$

**SOL 9.72**

For providing electrical isolation it is necessary to connect a pulse transformer at the output stage of a thyristor triggering circuit.

Hence (B) is correct option.

**SOL 9.73**

In ac to dc circulating current dual converters if triggering angles are  $\alpha_1$  and  $\alpha_2$ , then it is necessary that

$$\alpha_1 + \alpha_2 = 180^\circ$$

Hence (A) is correct option.

**SOL 9.74**

Given a half wave Thyristor converter supplies a purely inductive load

$$\text{Triggering angle } \alpha = 120^\circ$$

than extinction angle  $\beta = ?$

**NOTES**

(a) ∴ Motor Torque  $T = E_b I_a$  and  $E_b = K_v \omega$

Then  $K_v \omega I_a = T \omega$

$$I_a = \frac{T}{K_v} = \frac{140}{25} = 50 \text{ Amp}$$

(b) In dc motor we know

$$I_a = \frac{V_0 - E_b}{R_a}$$

$$E_b = V_0 - I_a R_a$$

$$E_b = \frac{500\sqrt{2}}{\pi} \times 2 - 20(0.2)$$

$$E_b = 215.2 \text{ V}$$

$$\omega = \frac{E_b I_a}{T} = \frac{215.2 \times 20}{140} = 30.74 \text{ rad/sec}$$

$$V_0 = \frac{2 V_m \cos \alpha}{\pi}$$

$$= \frac{2 \times 250\sqrt{2}}{\pi} \cos 60^\circ$$

(c) Rms value of fundamental component of input current

$$I_{sr} = \frac{I_{or}}{\sqrt{2} \left[ \frac{1}{\pi} \left( (\pi - \alpha) + \frac{1}{2} \sin 2\alpha \right) \right]^{1/2}}$$

$$I_{or} = 56 \text{ Amp}, \alpha = 60^\circ$$

$$I_{sr} = \frac{56}{\sqrt{2} \left[ \frac{1}{\pi} \left( \pi - \frac{\pi}{3} \right) + \frac{1}{2} \sin 120^\circ \right]^{1/2}}$$

$$I_{sr} = \frac{39.6}{\left( \frac{2}{3} - \frac{1}{4} \right)^{1/2}} = 61.34 \text{ Amp}$$

\*\*\*\*\*